

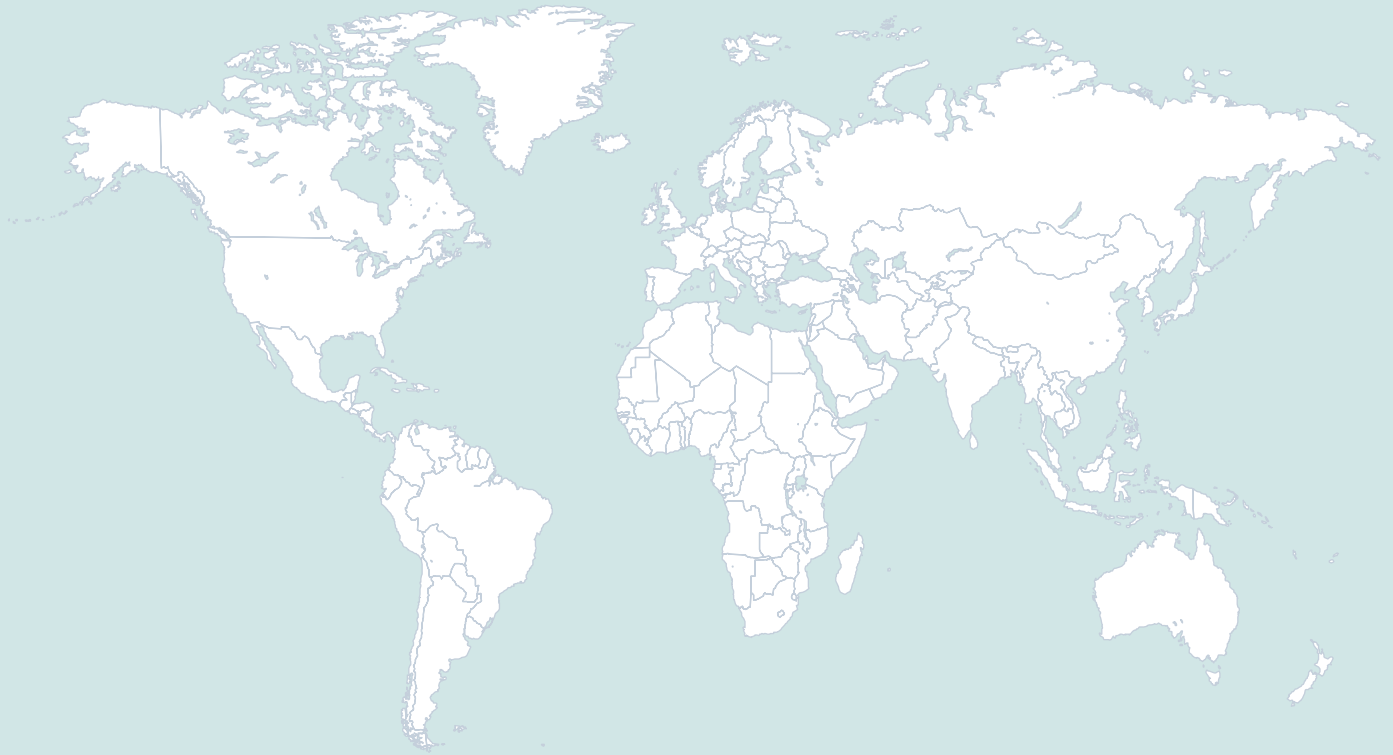

Catalog



MOVIDRIVE® MDX60B/61B





Contents

1	System Description.....	6
1.1	System overview of MOVIDRIVE® MDX60B/61B.....	6
1.2	Functions/features	19
1.3	Additional functions of the application variants	22
1.4	Application modules for MOVIDRIVE® MDX61B	26
1.5	MOVITOOLS® MotionStudio engineering software	35
2	Technical Data of Basic Unit.....	37
2.1	CE marking, UL approval and C-Tick	37
2.2	General technical data	38
2.3	MOVIDRIVE® MDX60/61B...-5_3 (AC 400/500 V units).....	40
2.4	MOVIDRIVE® MDX61B...-2_3 (AC 230 V units).....	49
2.5	MOVIDRIVE® MDX60/61B electronics data	53
2.6	MOVIDRIVE® MDX60B dimension drawings.....	55
2.7	MOVIDRIVE® MDX61B dimension drawings.....	57
2.8	IPOS ^{plus} ®	67
2.9	DBG60B keypad option	69
2.10	DBM60B/DKG60B housing option for DBG60B.....	71
3	Technical Data of Regenerative Power Supply Unit	72
3.1	MOVIDRIVE® MDR60A regenerative power supply units	72
4	Technical Data of Options	79
4.1	DEH11B Hiperface® encoder card option.....	79
4.2	DER11B resolver card option	80
4.3	DEU21B multi-encoder card option	81
4.4	DEH21B/DIP11B absolute encoder card option	82
4.5	Connector adapter for unit replacement MD_60A - MDX60B/61B	85
4.6	DWE11B/12B interface adapter option	87
4.7	UWS11A interface adapter option	89
4.8	UWS21B interface adapter option	91
4.9	USB11A interface adapter option	93
4.10	DWI11A DC 5 V encoders supply option	95
4.11	DIO11B input/output card option.....	97
4.12	DFP21B PROFIBUS fieldbus interface option	99
4.13	DFI11B INTERBUS fieldbus interface option.....	100
4.14	DFI21B INTERBUS optical fiber fieldbus interface option	101
4.15	DFE32B PROFINET IO RT fieldbus interface option.....	102
4.16	DFE33B EtherNet/IP and Modbus/TCP fieldbus interface option	104
4.17	DFE24B EtherCAT® fieldbus interface option.....	106
4.18	DFD11B DeviceNet fieldbus interface option.....	107
4.19	DFC11B CAN/CANopen fieldbus interface option	108
4.20	DRS11B synchronous operation card option.....	109



4.21	DFS11B fieldbus interface option PROFIBUS DP-V1 with PROFI-safe ..	110
4.22	DFS12B fieldbus interface option PROFIBUS DP-V1 with PROFI-safe ..	112
4.23	DFS21B fieldbus interface option PROFINET IO with PROFI-safe	113
4.24	DFS22B fieldbus interface option PROFINET IO with PROFI-safe	115
4.25	MOVISAFE [®] DCS21B/31B safety module option.....	116
4.26	MOVI-PLC [®] basic DHP11B controller option.....	119
4.27	OST11B option	120
4.28	DHE/DHF/DHR21 and DHE/DHF/DHR41B controller option	121
4.29	BST safety-related brake module option.....	127
5	Technical Data of External Accessories	129
5.1	DMP11B mounting panel option	129
5.2	DLB11B touch guard option.....	130
5.3	DLB21B touch guard option (for size 7).....	131
5.4	DLS11B mounting base option (for size 7)	132
5.5	DLH11B wall bracket (for size 7)	133
5.6	DLA11B connection kit option (for size 7).....	134
5.7	DLK11B air duct option (for size 7)	135
5.8	DLZ11B DC link coupling option (for size 7)	136
5.9	2Q DLZ12B DC link adapter option (for size 7)	137
5.10	4Q DLZ14B DC link adapter option (for size 7)	138
6	Technical Data of Braking Resistors, Chokes, and Filters	139
6.1	BW... braking resistor option / BW...-T / BW...-P	139
6.2	ND.. line choke option	150
6.3	NF...-... line filter option	152
6.4	HD... output choke option	156
6.5	HF... output filter option.....	159
7	Prefabricated Cables	163
7.1	Overview	163
7.2	Cable sets for DC link connection MDR → MDX	163
7.3	CM motor cables with connector on motor end	164
7.4	CM brakemotor cables with connector on motor end	165
7.5	CMD/CMP motor cables with connector on motor end.....	166
7.6	CMP brakemotor cables for BP brake with connector at motor end	166
7.7	CMP brakemotor cables for BY brake with connector at motor end	167
7.8	Encoder cable selection: Meaning of the symbols.....	168
7.9	Encoder cable for DR motors on X15 DEH11B/DEH21B/DEU21B	169
7.10	Encoder cable for DT/DV/CMP, CM, (DS) motors on X15 DEH11B/DEH21B and DEU21B.....	176
7.11	Encoder cable for distance encoders on X14, DEH11B / DER11B / DEU21B.....	182
7.12	Encoder cable for resolvers on X15 DER11B.....	187



8	Motor Selection	190
8.1	Basic recommendations for motor selection	190
8.2	Motor selection for asynchronous AC motors (VFC)	190
8.3	Motor selection for asynchronous AC and servomotors (CFC)	206
8.4	Motor selection for synchronous servomotors (SERVO)	272
9	Address Directory	292
	Index	312

kVA	n
f	
i	P Hz

System Description

System overview of MOVIDRIVE® MDX60B/61B

1 System Description

1.1 System overview of MOVIDRIVE® MDX60B/61B

1.1.1 Power components

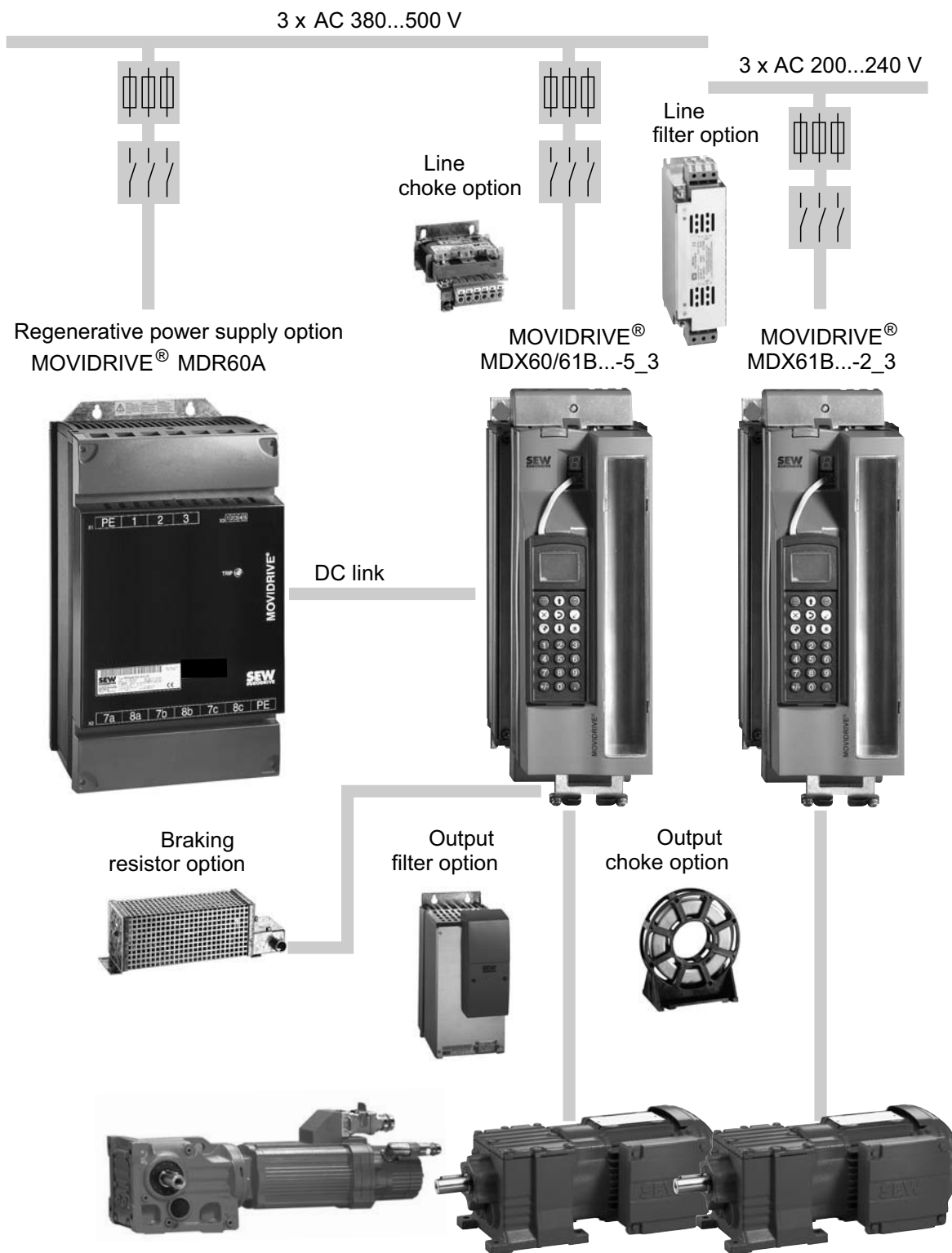

1452332683

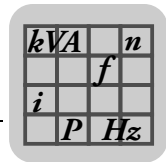

1.1.2 Encoder and communication options

MDX60/61B standard variant with IPOS plus®



MDX60/61B application version for the use of "electronic cam", "Internal synchronous operation" or the application modules.

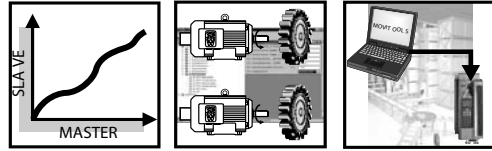

DBG60B keypad option



MOVITOOLS® engineering software

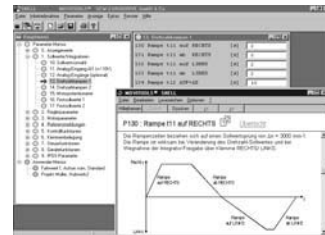

Encoder options:

- DEU 21B
- DEH 11B
- DEH 21B
- DER 11B
- DIP 11B
- DIO 11B
- DRS 11B

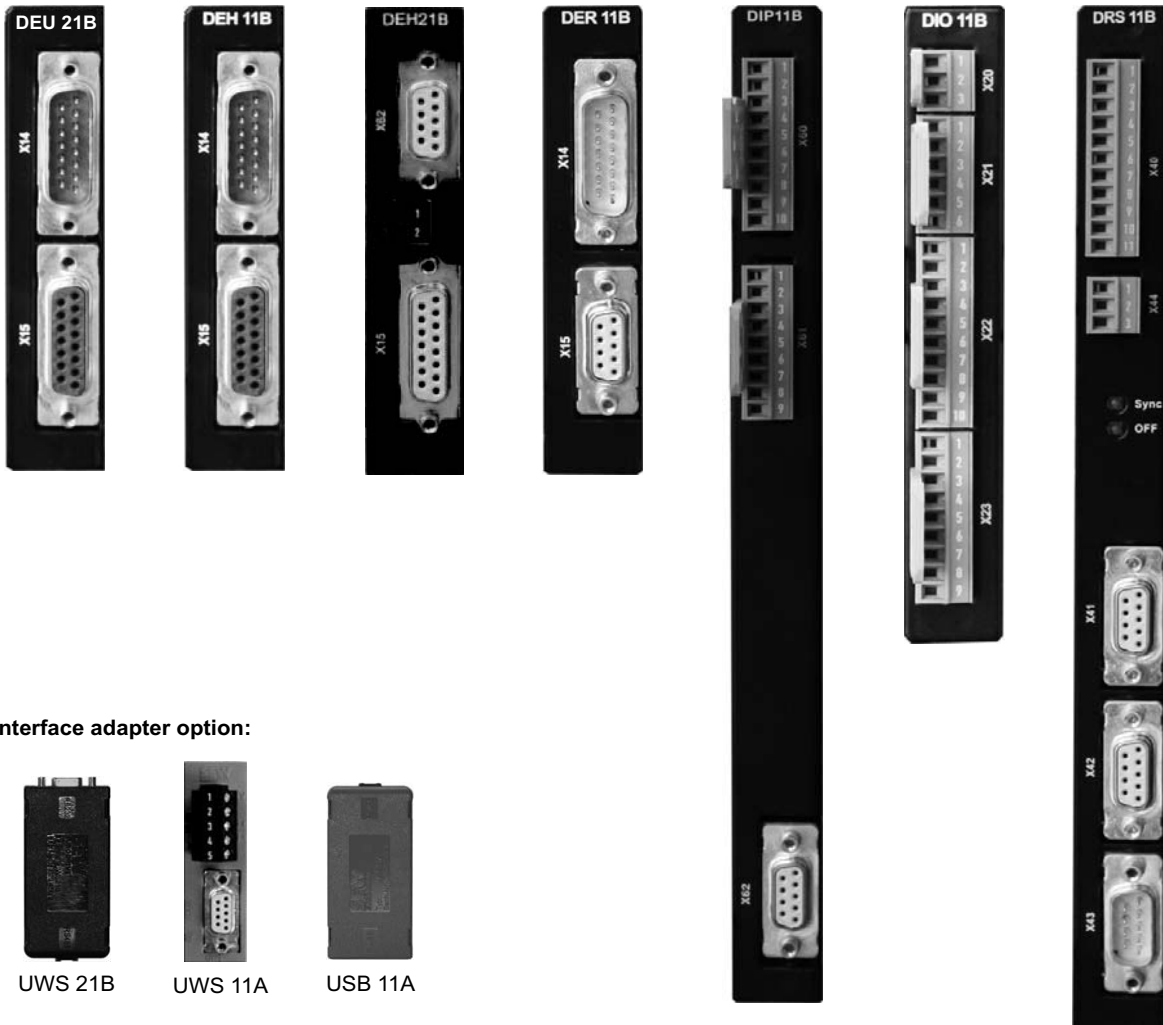

1452369291

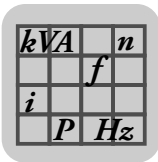

System Description

System overview of MOVIDRIVE® MDX60B/61B

1.1.3 Fieldbus options

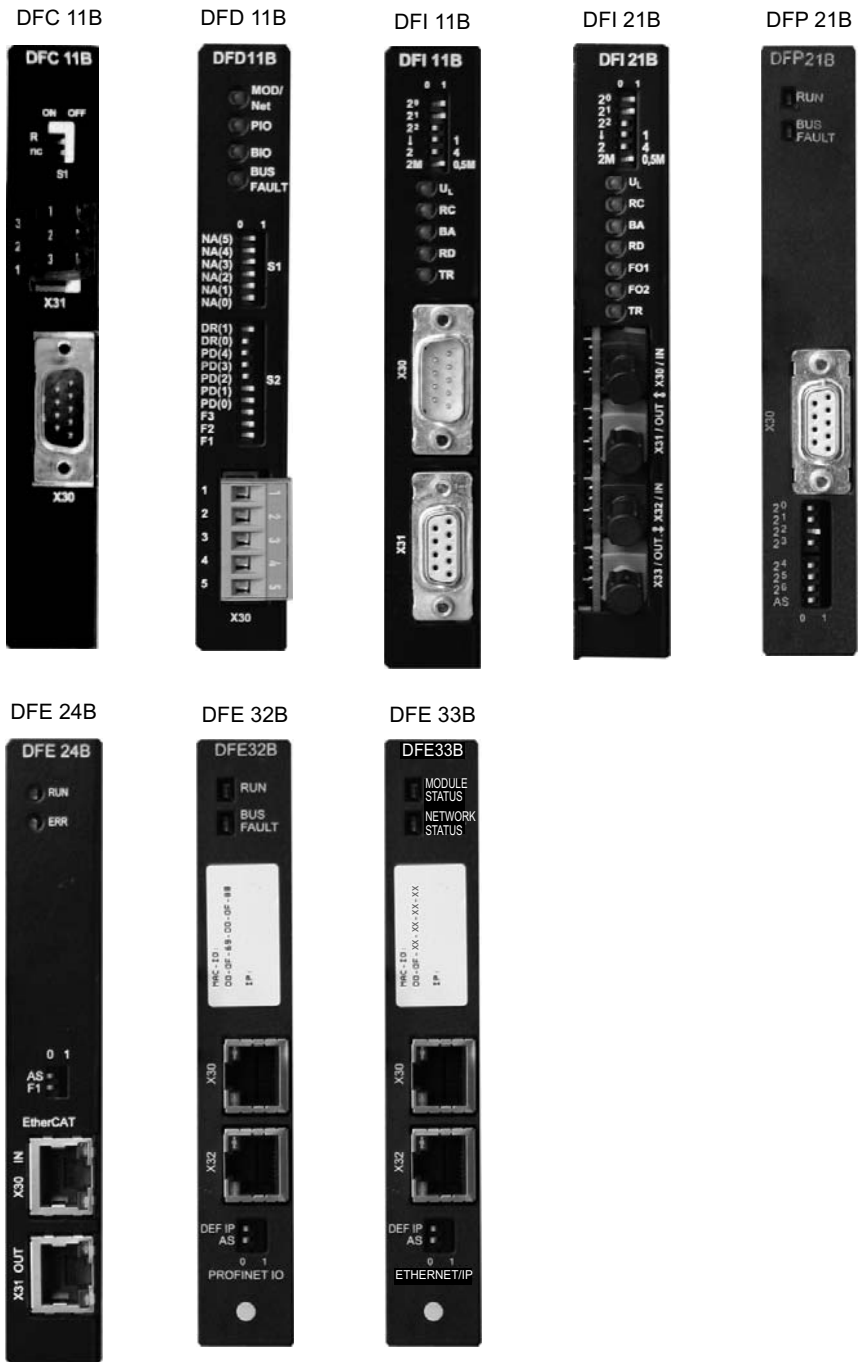

1452375307

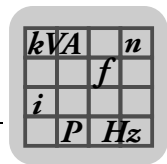

1.1.4 Control options

MOVI-PLC®

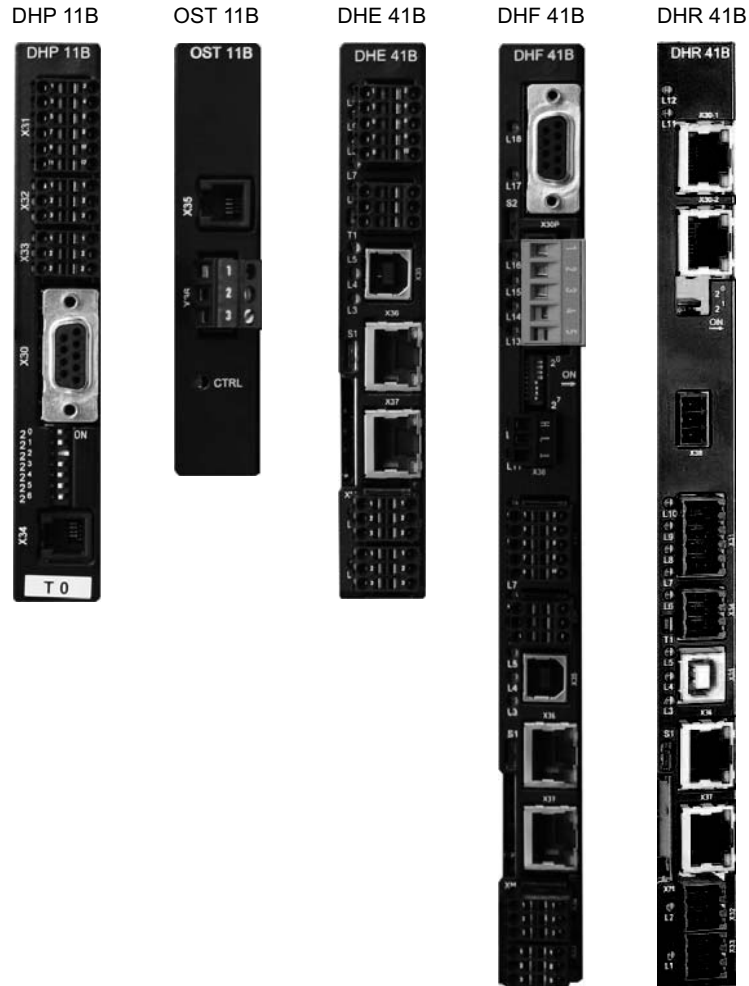

1452634507

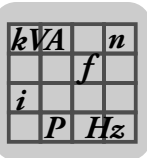

System Description

System overview of MOVIDRIVE® MDX60B/61B

1.1.5 Safety options

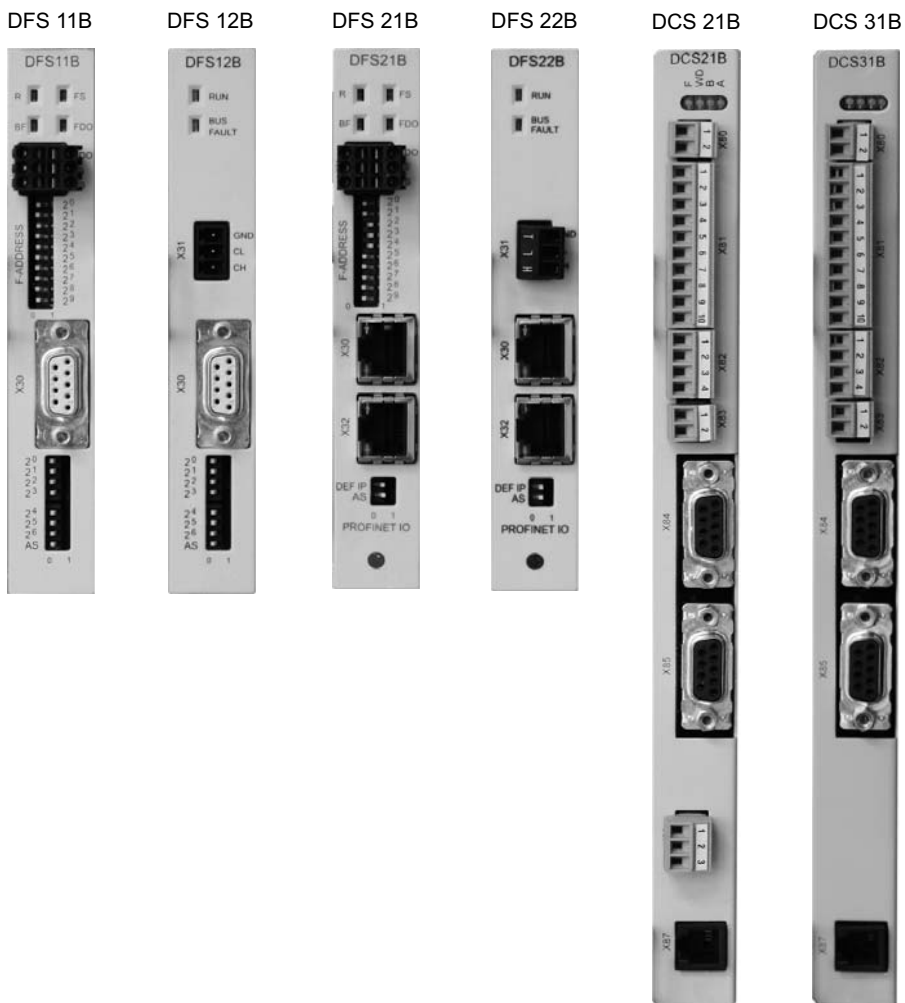

1452640907

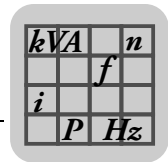

1.1.6 General description

MOVIDRIVE® MDX60B/61B is the new generation of drive inverters from SEW-EURODRIVE. The new MOVIDRIVE® B series inverters feature a modular design, provide enhanced functions in the lower power range, more basic functions, and greater overload capacity.

AC drives with the latest digital inverter technology can now be used without restrictions in the 0.55 to 315 kW power range. The levels of dynamic performance and control quality that can now be achieved with MOVIDRIVE® for asynchronous AC motors were previously only possible using servo drives or DC motors. The integrated control functionality and the option to extend the drive using technology and communication options creates drive systems that are designed to be particularly cost-effective with regards to the application range, project planning, startup and operation.

1.1.7 Low-emission

The MOVIDRIVE® MDX60B/61B inverters are produced according to particularly low-emission regulations, but with the usual high level of quality. One particular feature is the consistent use of lead-free soldering materials in the production of electronics products. These lead-free processes are in line with the RoHS EU Directive and the law on electronic equipment.

1.1.8 Product family

The **MOVIDRIVE®** product family includes three series:

- MOVIDRIVE® MDX60B: Drive inverter for asynchronous AC motors without encoder feedback. The units are not option-capable.
- MOVIDRIVE® MDX61B: Drive inverter for asynchronous AC motors with or without encoder feedback, or for asynchronous and synchronous servomotors. The units are option-capable.
- MOVIDRIVE® MDR60A: Regenerative power supply unit; MOVIDRIVE® inverters (400/500 V units) operate in regenerative mode to feed energy back into the supply system.

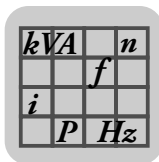

System Description

System overview of MOVIDRIVE® MDX60B/61B

1.1.9 Unit variants

MOVIDRIVE® MDX60/61B size 0-6 inverters are available in two variants, namely the standard variant and the application variant. MOVIDRIVE® MDX60B/61B size 7 inverters are only available as application variants with coated pcbs (-0T/L).

Standard variant

The units are equipped with integrated IPOS^{plus}® positioning and sequence control as standard. MOVIDRIVE® MDX61B can be expanded with the available options.

"00" at the end of the type designation indicates the standard variant.

Application variant

In addition to the features of the standard variant, these units include the technology functions "electronic cam" and "internal synchronous operation". Furthermore, you can use all the application modules available in the MOVITOOLS® MotionStudio engineering software with the application variants.

The application variant is indicated by "0T" following the type designation.

Variants with coated printed circuit boards

The units are designed for use in harsh environments. The coating of the printed circuit boards increases their resistivity against environmental conditions.

The variant with coated pcbs is indicated by "00/L" or "0T-/L" at the end of the type designation.

1.1.10 Modular unit concept

The option-capable MOVIDRIVE® MDX61B units have the following option slots:

- Size 0 (0005 ... 0014) → 2 option card slots
 - 1 option card slot for encoder connection
 - 1 option card slot for a communication option
- Sizes 1 ... 7 (0015 ... 2500) → 3 option card slots
 - 1 option card slot for encoder connection
 - 1 option card slot for a communication option
 - 1 option card slot for an expansion option

	INFORMATION
	<ul style="list-style-type: none"> • Customers can only install or remove option cards later on in MDX61B sizes 1 to 7. The firmware of the option cards and the basic unit must be compatible. • For MDX61B size 0 units, option cards can only be installed and removed later on by SEW-EURODRIVE. Please take this aspect into account when you place your order/perform project planning.

1.1.11 Option card slots of MOVIDRIVE® MDX61B

Size 0 (0005 ... 0014)

Size 1 ... 7 (0015 ... 2500)

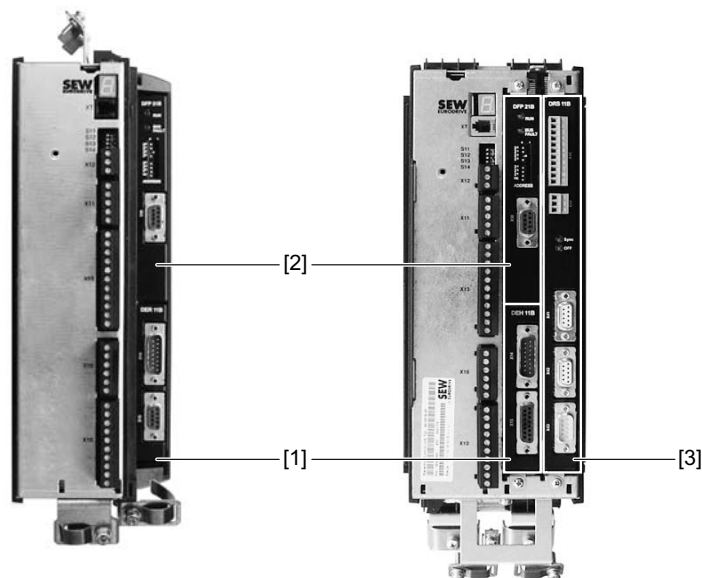

1806023691

- [1] Encoder slot for encoder option
- [2] Fieldbus slot for communication option
- [3] Expansion slot for communication option (only sizes 1 - 7)

The modular unit concept allows you to choose the right option according to your application. For example, when you have an asynchronous AC motor with encoder feedback (Hiperface®, sin/cos, or TTL), you would need the Hiperface® encoder card type option DEH11B.

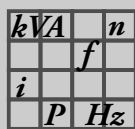

System Description

System overview of MOVIDRIVE® MDX60B/61B

Use	Required option	Option card slot
Encoder option		
Asynchronous AC motor with encoder feedback (Hiperface®, sin/cos, TTL)	Hiperface® encoder card DEH11B	1
Asynchronous or synchronous servomotor with Hiperface® encoder		
Synchronous servomotor with resolver	Resolver card type DER11B	
Asynchronous or synchronous motors with absolute encoder	DEU21B multi-encoder card	
SSI encoder interface	DEH21B absolute encoder card	
Communication options (fieldbus, control)		
User-programmable MOVI-PLC® controller	MOVI-PLC® basic DHP11B controller	2 (3 only if slot 2 is occupied)
Additional RS485 interface (only in combination with option DHP11B)	DHP11B + OST11B	<ul style="list-style-type: none"> DHP11B in 2, OST11B in 1 If 1 is occupied: DHP11B + OST11B in 3
Freely programmable motion and logic controller (MOVI-PLC®)	Controllers <ul style="list-style-type: none"> DHE21B (standard) DHE41B (advanced) 	2 (3 only if slot 2 is occupied)
	Controllers <ul style="list-style-type: none"> DHF21B (standard) DHF41B (advanced) 	3
	Controllers <ul style="list-style-type: none"> DHR21B (standard) DHR41B (advanced) 	3
Additional analog and binary inputs/outputs are required	Input/output card type DIO11B	2 (3 only if slot 2 is occupied)
Integration into a PROFIBUS system	PROFIBUS interface? type DFP21B	2
Integration into a PROFIBUS system with PROFIsafe	DFS11B fieldbus interface	
Integration into an INTERBUS system	INTERBUS interface type DFI11B / DFI21B	
Integration into an Ethernet system with PROFIsafe	DFS21B fieldbus interface	
Integration into an EtherCAT® system	EtherCAT interface type DFE24B	
Integration into a DeviceNet system	DeviceNet interface type DFD11B	
Integration into a CANopen system	CANopen interface type DFC11B	
Expansion option		
SSI encoder interface	DIP11B absolute encoder card	3
Phase-synchronous operation	Synchronous operation card DRS11B	
Safety module	DCS21B option (only in conjunction with DFS12B/22B option) / DCS31B	

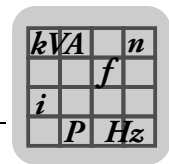

1.1.12 Control modes

The VFC (Voltage Mode Flux Control) and CFC (Current Mode Flux Control)/SERVO control modes are features of MOVIDRIVE® MDX60B/61B inverters. The continuous calculation of the complete motor model forms the basis for both control modes.

VFC control mode (Voltage Mode Flux Control)	Control modes CFC (Current Mode Flux Control)/SERVO
Voltage-controlled control mode for asynchronous AC motors with and without encoder feedback. <ul style="list-style-type: none"> • With encoder feedback <ul style="list-style-type: none"> – At least 150% torque, with a power-matched, stopped motor – Characteristics similar to servo operation • Without encoder feedback <ul style="list-style-type: none"> – min. 150% torque up to 0.5 Hz, with a power-matched motor 	Current-controlled control mode for asynchronous and synchronous servomotors. Encoder feedback is always required. <ul style="list-style-type: none"> • At least 160% torque, with a power-matched, stopped motor • Maximum precision and concentric running characteristics right down to standstill. • Servo characteristics and torque control even for asynchronous AC motors • Reacts to load changes within a few milliseconds

1.1.13 System bus (SBus)

The system bus (SBus), which is installed as standard, allows several MOVIDRIVE® inverters to be networked together. This system bus enables fast data exchange between the units. The MOVILINK® unit profile is used for communication via the SBus. MOVILINK® is the universal SEW-EURODRIVE standard for serial communication. The SBus can be switched to CANopen.

1.1.14 MOVILINK®

MOVILINK® always uses the same message format independent of the selected interface (SBus, RS232, RS485, fieldbus interfaces). As a result, the control software is independent of the selected interface.

1.1.15 IPOS^{plus}®

A significant feature of MOVIDRIVE® inverters is that the IPOS^{plus}® positioning and sequence control system is integrated as standard. IPOS^{plus}® enables you to control motion sequences directly in the inverter close to the machine. This way, load is taken off the higher-level controller and modular concepts can be implemented more easily.

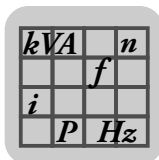

System Description

System overview of MOVIDRIVE® MDX60B/61B

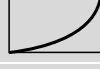

1.1.16 Overview of the units

MOVIDRIVE® MDX60/61B for 3 × AC 380 ... 500 V supply voltage (400/500 V units):

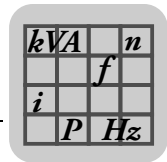
Recommended motor power (VFC)		Continuous output current (CFC)	MOVIDRIVE® type		Size (Techn. data)
			MDX60B not option-capable	MDX61B option-capable	
4Q units (with brake chopper)					
0.55 kW (0.74 HP)	0.75 kW (1.0 HP)	AC 2.0 A	0005-5A3-4..	0005-5A3-4..	0 (page 40)
0.75 kW (1.0 HP)	1.1 kW (1.5 HP)	AC 2.4 A	0008-5A3-4..	0008-5A3-4..	
1.1 kW (1.5 HP)	1.5 kW (2.0 HP)	AC 3.1 A	0011-5A3-4..	0011-5A3-4..	
1.5 kW (2.0 HP)	2.2 kW (3.0 HP)	AC 4.0 A	0014-5A3-4..	0014-5A3-4..	
1.5 kW (2.0 HP)	2.2 kW (3.0 HP)	AC 4.0 A	-	0015-5A3-4..	1 (page 42)
2.2 kW (3.0 HP)	3.0 kW (4.0 HP)	AC 5.5 A	-	0022-5A3-4..	
3.0 kW (4.0 HP)	4.0 kW (5.4 HP)	AC 7.0 A	-	0030-5A3-4..	
4.0 kW (5.4 HP)	5.5 kW (7.4 HP)	AC 9.5 A	-	0040-5A3-4..	
5.5 kW (7.4 HP)	7.5 kW (10 HP)	AC 12.5 A	-	0055-5A3-4..	2S, 2 (page 43)
7.5 kW (10 HP)	11 kW (15 HP)	AC 16 A	-	0075-5A3-4..	
11 kW (15 HP)	15 kW (20 HP)	AC 24 A	-	0110-5A3-4..	
15 kW (20 HP)	22 kW (30 HP)	AC 32 A	-	0150-503-4..	3 (page 44)
22 kW (30 HP)	30 kW (40 HP)	AC 46 A	-	0220-503-4..	
30 kW (40 HP)	37 kW (50 HP)	AC 60 A	-	0300-503-4..	
37 kW (50 HP)	45 kW (60 HP)	AC 73 A	-	0370-503-4..	4 (page 45)
45 kW (60 HP)	55 kW (74 HP)	AC 89 A	-	0450-503-4..	
55 kW (74 HP)	75 kW (100 HP)	AC 105 A	-	0550-503-4..	5 (page 46)
75 kW (100 HP)	90 kW (120 HP)	AC 130 A	-	0750-503-4..	
90 kW (120 HP)	110 kW (148 HP)	AC 170 A	-	0900-503-4..	6 (page 47)
110 kW (148 HP)	132 kW (177 HP)	AC 200 A	-	1100-503-4..	
132 kW (177 HP)	160 kW (215 HP)	AC 250 A	-	1320-503-4..	
-					
2Q units (without brake chopper)					
160 kW (215 HP)	200 kW (268 HP)	AC 300 A	-	1600-503-2-0T/L	7 (page 48)
200 kW (268 HP)	250 kW (335 HP)	AC 380 A	-	2000-503-2-0T/L	
250 kW (335 HP)	315 kW (422 HP)	AC 470 A	-	2500-503-2-0T/L	
4Q units (with brake chopper)					
160 kW (215 HP)	200 kW (268 HP)	AC 300 A	-	1600-503-4-0T/L	7 (page 48)
200 kW (268 HP)	250 kW (335 HP)	AC 380 A	-	2000-503-4-0T/L	
250 kW (335 HP)	315 kW (422 HP)	AC 470 A	-	2500-503-4-0T/L	



MOVIDRIVE® MDX60/61B for 3 × AC 200 ... 240 V supply voltage (230 V units):

Recommended motor power (VFC)		Continuous output current (CFC)	MOVIDRIVE® type MDX61B option-capable	Size (Technical data)
				
1.5 kW (2.0 HP)	2.2 kW (3.0 HP)	AC 7.3 A	0015-2A3-4..	1 (page 49)
2.2 kW (3.0 HP)	3.7 kW (5.0 HP)	AC 8.6 A	0022-2A3-4..	
3.7 kW (5.0 HP)	5.0 kW (7.0 HP)	AC 14.5 A	0037-2A3-4..	
5.5 kW (7.4 HP)	7.5 kW (10 HP)	AC 22 A	0055-2A3-4..	2 (page 50)
7.5 kW (10 HP)	11 kW (15 HP)	AC 29 A	0075-2A3-4..	
11 kW (15 HP)	15 kW (20 HP)	AC 42 A	0110-203-4..	3 (page 51)
15 kW (20 HP)	22 kW (30 HP)	AC 54 A	0150-203-4..	
22 kW (30 HP)	30 kW (40 HP)	AC 80 A	0220-203-4..	4 (page 52)
30 kW (40 HP)	37 kW (50 HP)	AC 95 A	0300-203-4..	

MOVIDRIVE® MDR60A regenerative power supply units for 400/500 V units:

MOVIDRIVE® MDR60A regenerative power supply units	Size (technical data)	MOVIDRIVE® MDX60B/61B...-5_3
0150-503-01	$I_{line} = AC\ 29\ A, I_{DC\ link} = DC\ 35\ A$	0005 ... 0150
0370-503-00	$I_{line} = AC\ 66\ A, I_{DC\ link} = DC\ 70\ A$	0005 ... 0370
0750-503-00	$I_{line} = AC\ 117\ A, I_{DC\ link} = DC\ 141\ A$	0005 ... 0750
1320-503-00	$I_{line} = AC\ 225\ A, I_{DC\ link} = DC\ 270\ A$	0005 ... 1320
1320-503-00 As of series no. DCV2000100	$I_{line} = AC\ 260\ A, I_{DC\ link} = DC\ 324\ A$	0005 ... 1600

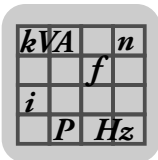

System Description

System overview of MOVIDRIVE® MDX60B/61B

1.1.17 Block circuit diagram

The following block circuit diagram shows the basic structure and theory of operation of MOVIDRIVE® MDX60B/61B inverters.

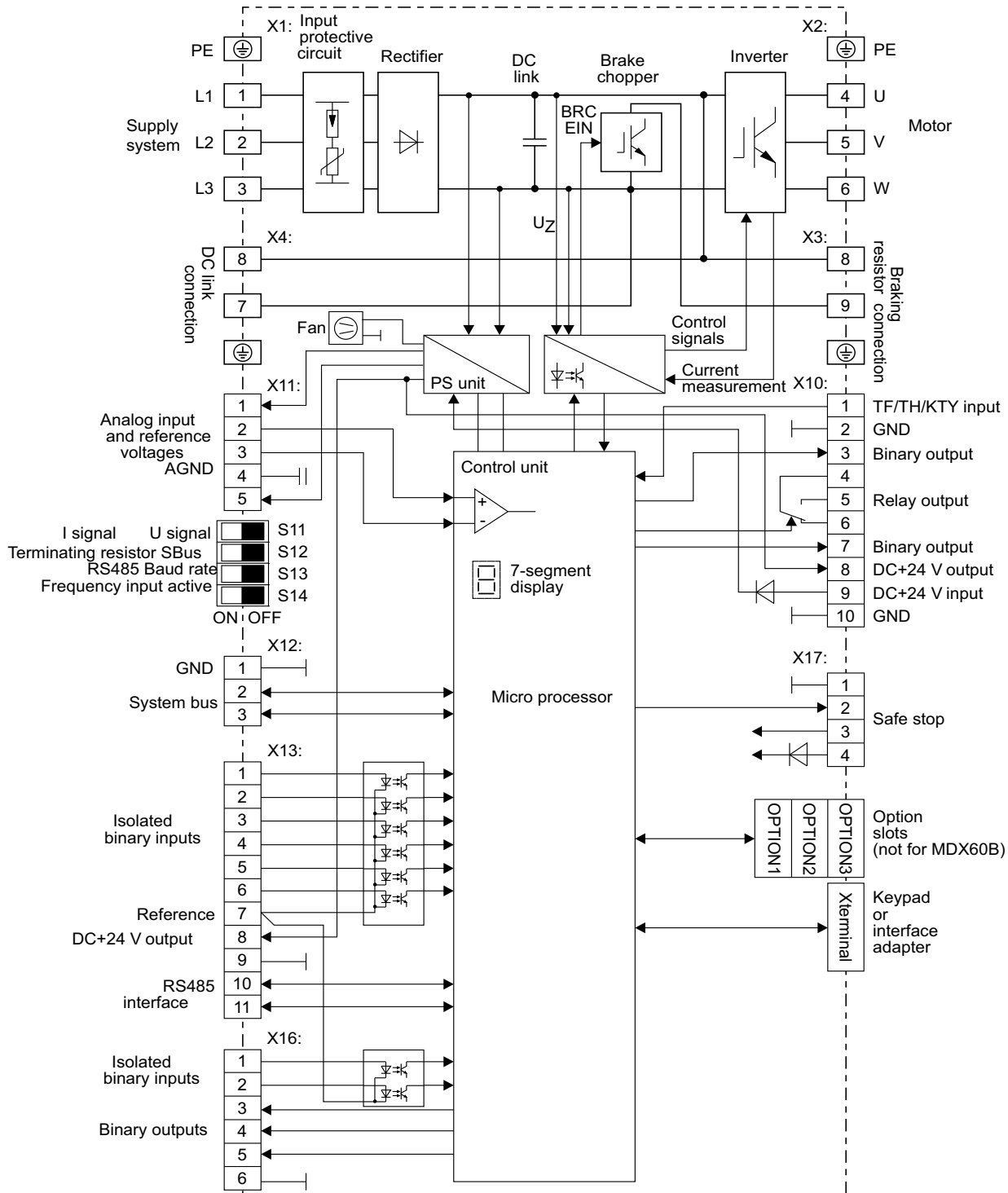

1452719115

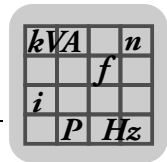

1.2 Functions/features

1.2.1 Unit features

- Wide voltage range
 - 400/500 V units for the voltage range 3 × AC 380 ... 500 V
 - 230 V units for the voltage range 3 × AC 200 ... 240 V
- High overload capacity
 - Size 0: 200 % I_N for at least 60 s
 - Sizes 1 ... 6: 150 % I_N for at least 60 s
 - All sizes: 125% I_N , continuous operation without overload (pumps, fans)
- Sizes 0 ... 6:
 - With 4 kHz switching frequency, I_N is permitted for an ambient temperature of $\vartheta = 50\text{ °C}$
 - 4Q capability due to integrated brake chopper installed as standard
- Size 7:
 - With 2.5 kHz switching frequency, I_N is permitted for an ambient temperature of $\vartheta = 50\text{ °C}$
 - 2Q units without brake chopper or 4Q units with brake chopper can be selected
- Compact unit design for minimum control cabinet space requirement and optimum utilization of control cabinet volume
- Integrated input filter fitted as standard in sizes 0, 1, 2S and 2, adherence to class C2 limit on the input side without any additional measures
- 8 isolated binary inputs and 6 binary outputs, one of which is a relay output; programmable inputs/outputs
- 1 TF/TH/KTY input for motor protection using a PTC thermistor or thermocontact
- 7-segment display for operating and fault states
- Separate DC 24 V voltage input for powering the inverter electronics (parameter setting, diagnostics and data storage even when the supply system is switched off)
- Separable electronic terminals
- Separable power terminals for size 0 and 1 units
- Safe stop in line with EN 954-1 and EN ISO 13849-1

1.2.2 Control functions

- VFC or CFC control modes for field-oriented operation (asynchronous servo)
- IPOS^{plus}® positioning and sequence control system integrated as standard
- Two complete parameter sets
- Automatic motor calibration
- Automatic brake control by the inverter
- DC braking to decelerate the motor even in 1Q mode
- Energy-saving function to automatically optimize the magnetization current
- Slip compensation for high stationary speed accuracy, even without encoder feedback

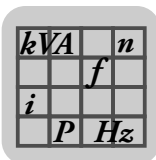

System Description

Functions/features

- Flying restart function for synchronizing the inverter to an already rotating SEW motor
- Hoist capability with all motor systems that can be connected
- Motor stall protection through sliding current limitation in the field weakening range
- Function to hide speed window to avoid mechanical resonances
- Heating current to avoid condensation build-up in the motor
- Parameter lock for protection against changes to parameters
- Speed controller and encoder input for incremental, Hiperface® or SSI encoders and resolver. User-friendly controller setting tool in the operator interface.
- Protective functions for complete protection of the inverter and motor (short-circuit, overload, overvoltage/undervoltage, ground fault, excess temperature in the inverter, motor stall prevention, excess temperature in the motor)
- Speed monitoring and monitoring of the motor and regenerative limit power
- Programmable signal range monitoring (speed, current, maximum current)
- Memory for displaying X/t diagrams using SCOPE process data visualization four channels (8 channels, real-time capable)
- Fault memory (5 memory locations) with all relevant operating data at the time of the fault
- Elapsed-hour counter for hours of operation (unit connected to supply system or DC 24 V) and enable hours (output stage energized)
- Modular option technology for application-specific unit configuration
- Uniform operation, identical parameter setting and the same unit connection technology for the entire MOVIDRIVE® unit series

1.2.3 Setpoint technology

- Ramp switchover (total of 4 ramps)
- Motor potentiometer, can be combined with analog setpoint and internal fixed setpoints
- External setpoint selections: DC (0 ... +10 V, -10 V ... +10 V, 0 ... 20 mA, 4 ... 20 mA)
- S pattern for jerk-free speed changes
- Programmable input characteristic curve for flexible setpoint processing
- 6 bipolar fixed setpoints which can be mixed with external setpoints and motor potentiometer function
- Primary frequency input
- Adjustable jerk limitation

1.2.4 Communication/operation

- System bus for networking max. 64 MOVIDRIVE® units to one another
- RS485 interface for communication between one PLC/IPC and up to 31 inverters
- Simple startup and parameter setting using a keypad or PC
- Pluggable memory module for quick unit replacement during service

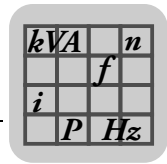

1.2.5 System expansion

- Extensive expansion options, for example:
 - Removable plain text keypad with parameter memory
 - USB11A, RS232 ↔ RS485 interface adapter
 - Fieldbus interface, either PROFIBUS, INTERBUS, Ethernet, DeviceNet, CAN/CANopen
 - Input/output card
 - Braking resistors, line filters, line chokes, output chokes, output filters
- MOVITOOLS[®] MotionStudio with SCOPE process data visualization
- Application variant with access to technology functions and application modules to solve drive tasks quickly and easily
- MOVIDRIVE[®] MDR60A regenerative power supply unit. Regenerative energy is fed back into the supply system, which removes the thermal load from the control cabinet and saves costs.

1.2.6 Standards and approvals

- UL, cUL, C-Tick approval. The MOVIDRIVE[®] MDR60A1320-503-00 unit does not have UL or cUL or C-Tick approval. The GOST-R certificate (Russia) is approved for the MOVIDRIVE[®] range of units.
- Safe disconnection of power and electronic connections according to EN 61800-5-1
- Compliance with all the requirements for CE certification of machines and plant equipped with MOVIDRIVE[®] on the basis of the Low Voltage Directive 2006/95/EC and the EMC Directive 2004/108/EC. Complies with the EMC product standard EN 61800-3.
- Complies with the "Safe Stop" safety requirement according to EN 954-1, category 3
- Approved for use in applications for performance level d according to EN ISO 13849-1

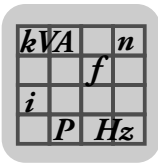

System Description

Additional functions of the application variants

1.3 Additional functions of the application variants

SEW-EURODRIVE offers additional functions for special applications. You can use these additional functions with the MOVIDRIVE® application variants (...-0T).

The following additional functions are available:

- Electronic cam
- Internal synchronous operation

	INFORMATION
	Please refer to the "Electronic Cam" and "Internal Synchronous Operation" manuals for detailed information about the additional functions.

1.3.1 Electronic cam



You can use the MOVIDRIVE® product series with the "electronic cam" module whenever you need to harmonize complex sequences of motion in cyclical machines. This solution gives you much greater flexibility in comparison to the mechanical cam. As a result, it meets the needs of modern production and processing lines.

A user-friendly cam editor supports you during startup. You also have the option of importing existing cam data. You can also set application-specific parameters for the engagement and disengagement phases using the cam editor.

Note the following points:

- The "electronic cam" can only be implemented with the MOVIDRIVE® MDX61B application variants (...-0T).
- Encoder feedback is mandatory. This is why the "electronic cam" can only be realized in "CFC", "SERVO" and "VFC-n control" operating modes with master/slave connection via X14-X14 or with an SBus connection.
- "Electronic cam" is only available in parameter set 1.
- The "DRS11B synchronous operation card" option cannot be used together with the "electronic cam" function.

kVA		n
	f	
i		
P		Hz

Motors and encoders

Use the following motor types:

- For operation with MOVIDRIVE® MDX61B...-4-0T:
 - CT/CV asynchronous servomotor, high-resolution sin/cos encoder installed as standard or Hiperface® encoder.
 - DT/DV/D series AC motor with incremental encoder, preferably high-resolution sin/cos encoder or Hiperface® encoder.
 - Synchronous servomotors DS/CM/CMD/CMP, resolver (installed as standard) or Hiperface® encoder

High-resolution speed measurement is required for optimum operation of the electronic cam. The encoders installed as standard on CT/CV and DS/CM/CMD/CMP motors fulfill these requirements. SEW-EURODRIVE recommends using high-resolution sin/cos encoders as incremental encoders if DR/DT/DV/D motors are used.

Example

The figure below shows a typical application example for the "electronic cam." Filled yogurt pots are transported for further processing. The "electronic cam" enables smooth movement, which is an important requirement for this application.

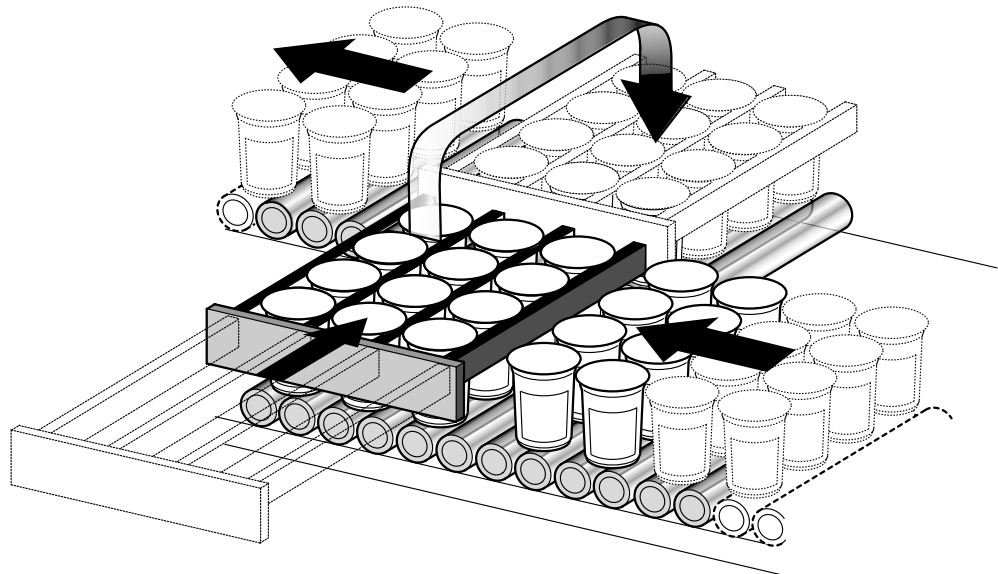

1453201035

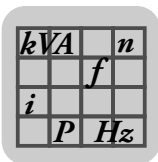

System Description

Additional functions of the application variants

1.3.2 Internal synchronous operation

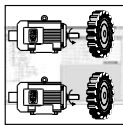

You can always use the MOVIDRIVE[®] unit series with "internal synchronous operation" whenever a group of motors has to be operated at a synchronous angle in relation to one another or with an adjustable proportional ratio (electronic gear). A user-friendly editor guides you through the startup procedure.

Note the following points:

- "Internal synchronous operation" can only be implemented with MOVIDRIVE[®] MDX61B application variants (...-0T).
- Encoder feedback is mandatory. This is why "internal synchronization operation" can only be realized in "CFC", "SERVO" and "VFC-n control" operating modes with master/slave connection via X14-X14 or with an SBus connection.
- "Internal synchronous operation" is only available in parameter set 1.
- The "DRS11B synchronous operation card" option cannot be used together with "internal synchronous operation".

Motors and encoders

Use the following motor types for operation with MOVIDRIVE[®] MDX61B...-4-0T:

- CT/CV asynchronous servomotor, high-resolution sin/cos encoder installed as standard or Hiperface[®] encoder.
- DT/DV/D series AC motor with incremental encoder, preferably high-resolution sin/cos encoder or Hiperface[®] encoder.
- Synchronous servomotors DS/CM/CMD/CMP, resolver (installed as standard) or Hiperface[®] encoder

High-resolution speed measurement is required for optimum "internal synchronous operation". The encoders installed as standard on CT/CV and DS/CM/CMD/CMP motors fulfill these requirements. SEW-EURODRIVE recommends using high-resolution sin/cos encoders as incremental encoders if DR/DT/DV/D motors are used.

kVA		n
		f
i		
P		Hz

Example

The figure below shows a typical application with "internal synchronous operation". Extruder material must be cut to length. The saw receives a start signal and synchronizes with the material. During the sawing process, the saw moves synchronously with the material. At the end of the sawing process the saw moves back to its starting position.

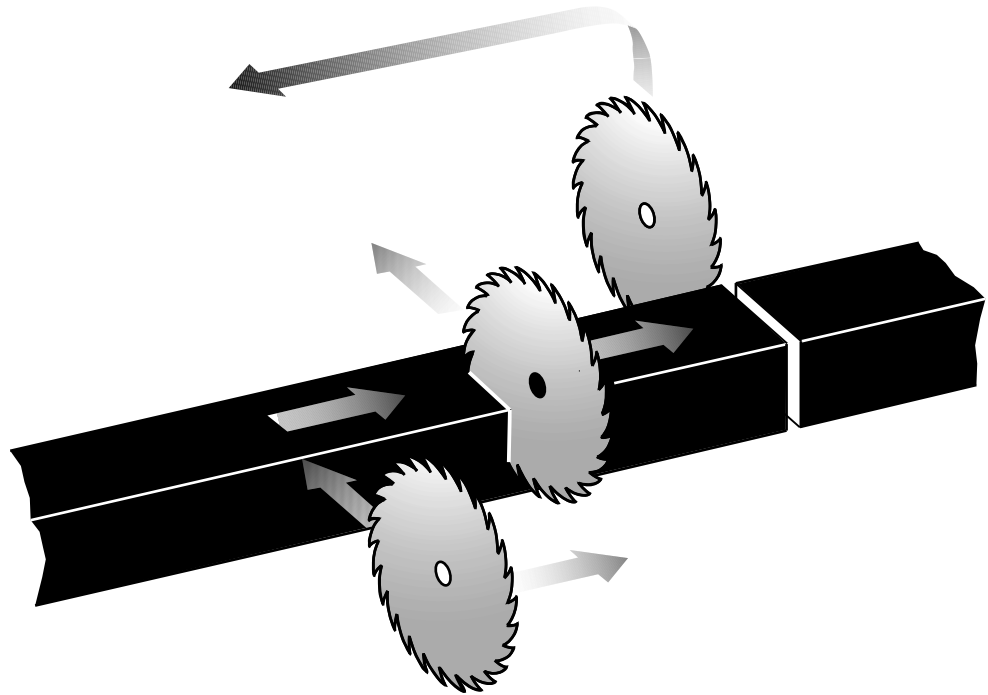

41692939

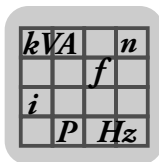

1.4 Application modules for MOVIDRIVE® MDX61B

1.4.1 The drive task

The drive task often involves more than just adjusting the speed of a motor. The inverter often has to control motion sequences and take on typical PLC tasks. Increasingly complex drive applications have to be solved, without this resulting in lengthy configuration and startup processes.

1.4.2 The solution with MOVIDRIVE®

SEW-EURODRIVE offers various standardized control programs specifically for "positioning," "winding," and "controlling" applications. These programs are called application modules. The application modules are incorporated into MOVITOOLS® MotionStudio and can be used with the application variants.

A user-friendly operator interface guides you through the process of setting the parameters. All you have to do is enter the parameters you need for your application. The application module uses this information to create the control program and loads it into the inverter. MOVIDRIVE® takes over complete control of the motion processes, the load is taken off the machine control and decentralized concepts are easier to implement.

The advantages at a glance

- A wide range of functions
- A user-friendly GUI
- You only have to enter the parameters needed for the application
- Guided parameter setting process instead of complicated programming
- No programming experience required
- No lengthy training, therefore quick project planning and startup
- All movements are controlled directly in MOVIDRIVE®
- Decentralized concepts can be implemented more easily

1.4.3 Scope of delivery and documentation

The application modules are part of the MOVITOOLS® MotionStudio engineering software and can be used with MOVIDRIVE® MDX61B application variants (...-0T). The individual application manuals can also be downloaded as PDFs from the SEW website.

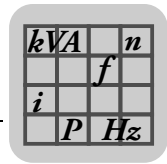

1.4.4 Available application modules

The application modules currently available are listed below. These application modules are explained in the following pages.

Positioning

Linear movement; the inverter manages the movement records:

- Table positioning via terminal or fieldbus

Linear movement; the PLC manages the movement records:

- Bus positioning
- Extended positioning via bus
- Absolute positioning (Rapid/creep speed positioning)

Rotary movement:

- Module positioning via terminals: The inverter manages the movement records
- Module positioning via fieldbus: The PLC manages the movement records

Winding

- Center winder

Control

- Flying saw
- DriveSync via fieldbus
- Sensor-based positioning

kVA		n
	f	
i		
P	Hz	

System Description

Application modules for MOVIDRIVE® MDX61B

1.4.5 Application

The following figure shows an example of how the various SEW application modules are used in a block warehouse.

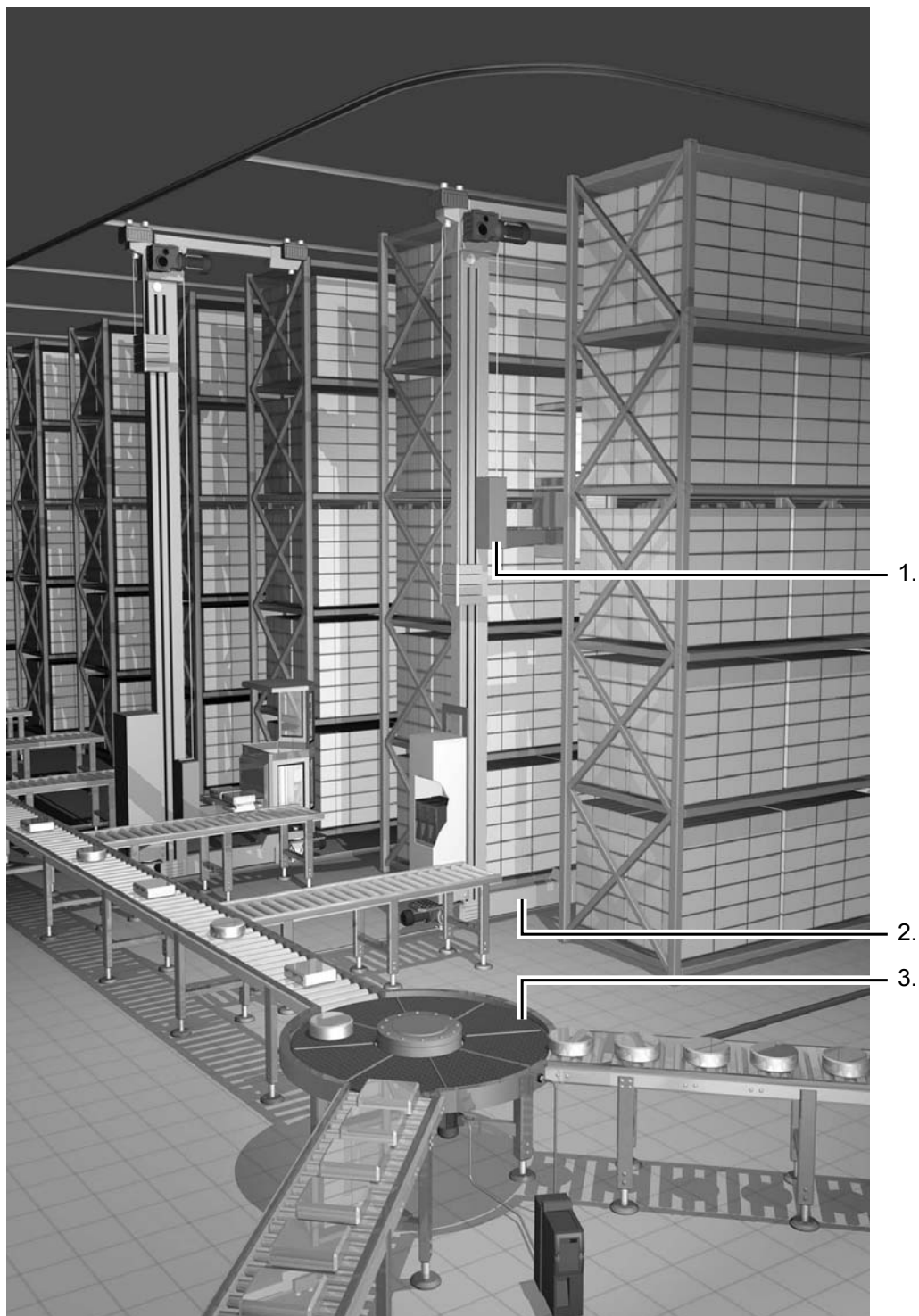

1453256971

1. Hoist: Table positioning
2. Travel axis: Absolute or bus positioning
3. Rotary distributor: Modulo positioning

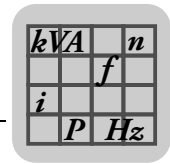

1.4.6 Positioning

The application modules for "Positioning" are suited to all applications in which target positions are specified and movement then takes place to those positions. Movement can either be linear or rotary.

For example, trolleys, hoists, gantries, rotary tables, swiveling devices, and storage and retrieval systems.

1.4.7 Linear positioning

In the case of application modules for linear positioning, SEW-EURODRIVE distinguishes between whether the movement records are administered in the inverter or in the higher-level PLC.

Movement records in the inverter

- **Table positioning via terminals**
- **Table positioning via fieldbus**

These application modules are suited to applications in which movement only has to take place to a limited number of target positions and in which the highest possible degree of independence from the machine control is required.

Up to 32 movement records can be managed in the inverter in these application modules. A movement record comprises target position, speed and ramp. The target position to which movement is to take place is selected using binary code, by means of the binary inputs of the inverter or via the virtual terminals (fieldbus, system bus). These application modules have the following features:

- Up to 32 table positions can be defined and selected.
- The travel speed can be selected for each positioning movement.
- The ramp can be set separately for each positioning movement.
- Software limit switches can be defined and evaluated.
- Either incremental or absolute encoders can be evaluated.
- Guided startup and diagnostics.

Four operating modes are available for controlling the machine:

- Jog mode: The machine can be moved manually.
- Reference travel: The machine zero is determined automatically for incremental position measurement.
- Teach-In: The saved position can be corrected without a programming device.
- Automatic mode: The higher-level PLC controls the process automatically.

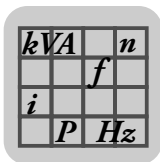

System Description

Application modules for MOVIDRIVE® MDX61B

*Movement records
in the PLC*

- **Bus positioning**
- **Extended positioning via bus**

These application modules are suited to applications with a high number of different target positions.

The movement records are managed in the PLC for these application modules. The target position and travel speed are specified via the fieldbus or system bus. These application modules have the following features:

- Any number of target positions can be defined and selected by means of a fieldbus/system bus.
- The travel speed can be selected as required via the fieldbus / system bus for each positioning movement.
- Software limit switches can be defined and evaluated.
- Either incremental or absolute encoders can be evaluated.
- Easy connection to the higher-level controller.
- Guided startup and diagnostics.

Three operating modes are available for controlling the machine:

- Jog mode: The machine can be moved manually.
- Reference travel: The machine zero is determined automatically for incremental position measurement.
- Automatic mode: The higher-level PLC controls the process automatically.

- **Absolute positioning (Rapid/creep speed positioning)**

In this application module, the movement records are also managed in the PLC and specified via the fieldbus or system bus. No motor encoder is required. The absolute encoder mounted on the travel path is used for positioning. This application module has the following features:

- Any number of target positions can be defined and selected via fieldbus/system bus.
- Software limit switches can be defined and evaluated.
- Only absolute encoders are used for position measurement.
- No motor encoder is required.
- Easy connection to the higher-level controller.
- Guided startup and diagnostics.

Two operating modes are available for controlling the machine:

- Jog mode: The machine can be moved manually.
- Automatic mode: The higher-level PLC controls the process automatically.

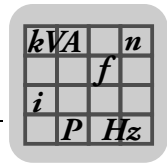

1.4.8 Rotatory positioning

- **Modulo positioning**

A large number of movements have to be controlled in automated conveyor and logistics applications to transport the material. Linear movements in the form of trolleys or hoists, and rotatory movements via rotary tables play a key role in these applications.

Rotary movements are often synchronized (rotary tables); the material is fed at a specific degree value. However, there are also many rotational applications in which the material should be moved to its destination by the shortest possible route (distance-optimized positioning) or in which it is only permitted to move to the target position in a defined direction of rotation (positioning with fixed direction of rotation).

The position axis is represented on a numbered circle from 0° to 360° to meet these requirements. The actual position is always in this range.

The "modulo positioning" application module accomplishes these tasks using various operating modes which are selected via binary inputs (16 table positions) or virtual terminals (control via fieldbus, variable positions).

The following operating modes are available for controlling the machine:

- Jog mode
- Teach mode (terminal control only)
- Referencing mode
- Automatic mode with position optimization
- Automatic mode with direction of rotation inhibit (clockwise - counterclockwise)
- Synchronous automatic mode

The "modulo positioning" module offers the following advantages:

- A user-friendly GUI
- Only the parameters required for Modulo positioning (number of teeth in the gear unit, speed) have to be entered
- Guided parameter setting instead of complicated programming
- Monitor mode for optimum diagnosis
- Users do not need any programming experience
- Rapid familiarization with the system

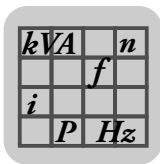

System Description

Application modules for MOVIDRIVE® MDX61B

1.4.9 Winding

- **Center winder**

The "Central winder" application module is suitable for applications in which endless material, such as paper, plastic, fabrics, sheet metal or wire, must be wound, unwound or rewound continuously.

Control takes place either via the binary inputs of the inverter or via the virtual terminals (fieldbus, system bus).

The "central winder" application module has the following features:

- Constant tensile force or web speed independent of the diameter.
- Automatic calculation of the speed-dependent friction factors via a teach-in run.
- Winding characteristics to prevent the winding material from becoming loose.
- Binary selection of 4 different winding cores.
- Diameter can be determined using a diameter calculator (master encoder required) or an analog input (distance sensor required).
- Free-running function (jog).
- CW/CCW winding, winding/unwinding.
- Simple connection to the higher-level controller (PLC).
- Guided startup and diagnostics.

Four operating modes are available for controlling the machine:

- Jog mode: The machine can be moved to the right or the left manually.
- Teach-in run: The speed-dependent friction factors are determined automatically.
- Automatic mode with constant tension.
- Automatic mode with constant velocity.

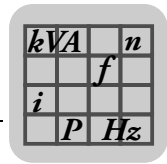

1.4.10 Control

- **Flying saw**

The "Flying saw" application module is suited to applications in which endless material has to be cut, sawn or pressed, for example in diagonal saws or flying punches.

This application module is used to control the sequence of motion according to specific values. This application module has the following features:

- Choice of fieldbus or terminal control.
- Cut edge protection or singling using the "Draw gap" function.
- Immediate cut function by manual interrupt.
- Counter for material length.
- Easy connection to the higher-level controller.
- Guided startup and diagnostics.

Four operating modes are available for controlling the machine:

- Jog mode: The machine can be moved manually.
- Reference travel: The system reference point is determined.
- Positioning mode
- Automatic operation

- **DriveSync via fieldbus**

The "DriveSync via fieldbus" application module makes it possible to implement conveyor systems and machinery with drives that have to move at a synchronous angle occasionally or permanently.

The program can be used for the master drive and the slave drive. The master works in the "Jog" and "Positioning" operating modes, while the slave drives are operated in "synchronous operation" mode.

If the "Synchronous operation" mode is deselected for the slave drives, they can be operated with free-running in "Jog" and "Positioning" operating modes.

The "DriveSync via fieldbus" application module has the following features:

- Guided startup and extensive diagnostics functions.
- High degree of similarity with procedures learned for the "Extended positioning".
- One program module for master and slave drive.
- The selected IPOS^{plus}® encoder source is also effective in synchronous operation.
- The master value for "synchronous operation" mode can be adjusted.
- A mechanical vertical shaft can be replaced by transferring the virtual master value via an SBus connection.
- Endless rotation is supported by the modulo function.

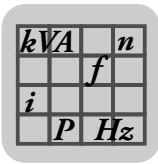

System Description

Application modules for MOVIDRIVE® MDX61B

Four operating modes are available for controlling the application:

- Jog mode
- Reference travel
- Positioning mode
- Synchronous operation
 - The electrical connection of the master/slave can be made using the X14 encoder connection or an SBus connection.
 - If the SBus connection is used, the content of the send object can be adjusted.
 - Time or position-related sequence of motion for synchronization processes.
 - The startup cycle process can also be started with interrupt control.

- **Sensor-based positioning**

This application module is used to position the drive using an external sensor signal plus an adjustable remaining distance. This application module is especially suitable for applications in the following industrial sectors:

- Materials handling
 - Trolleys
 - Hoists
 - Rail vehicles
- Logistics
 - Storage and retrieval systems
 - Transverse carriages

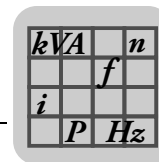

1.5 MOVITOOLS® MotionStudio engineering software

1.5.1 Tasks

The software package enables you to perform the following tasks with consistency:

- Establishing communication with units
- Executing functions with the units

1.5.2 Establishing communication with the units

The SEW Communication Server is integrated into the MOVITOOLS® MotionStudio software package for establishing communication with the units.

The SEW Communication Server allows you to create **communication channels**. Once the channels are established, the units communicate via these communication channels using their communication options. You can operate up to four communication channels at the same time.

MOVITOOLS® MotionStudio supports the following types of communication channels:

- Serial (RS-485) via interface adapters
- System bus (SBus) via interface adapters
- Ethernet
- EtherCAT®
- Fieldbus (PROFIBUS DP/DP-V1)
- Tool Calling Interface

The available channels can vary depending on the units and its communication options.

1.5.3 Executing functions with the units

The software package offers uniformity in executing the following functions:

- Parameterization (for example in the parameter tree of the unit)
- Startup
- Visualization and diagnostics
- Programming

The following basic components are integrated into the MOVITOOLS® MotionStudio software package, allowing you to use the units to execute functions:

- MotionStudio
- MOVITOOLS®

All functions communicate using **tools**. MOVITOOLS® MotionStudio provides the right tools for every unit type.

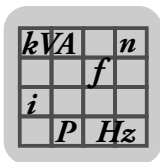

1.5.4 Technical support

SEW-EURODRIVE offers you a 24-hour service hotline.

Simply dial **(+49) 0 18 05** and then enter the letters **SEWHELP** via the telephone keypad. Of course, you can also dial **(+49) 0 18 05 - 7 39 43 57**.

1.5.5 Online help

After installation, the following types of help are available to you:

- This documentation is displayed in a help window after you start the software.
If the help window does not appear at the start, deactivate the "Display" control field, in the menu under [Settings] / [Options] / [Help].
If the help window appears again, activate the "Display" control field, in the menu under [Settings] / [Options] / [Help].
- Context-sensitive help is available for the fields which require you to enter values. For example, you can use the <F1> key to display the ranges of values for the unit parameters.

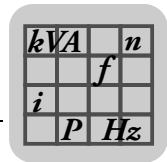

2 Technical Data of Basic Unit

2.1 CE marking, UL approval and C-Tick

2.1.1 CE-marking

- Low voltage directive
MOVIDRIVE® MDX60B/61B inverters comply with the regulations of the Low Voltage Directive 2006/95/EC.
- Electromagnetic compatibility (EMC)
The designated use of MOVIDRIVE® inverters and regenerative power supply units is as components for installation in machinery and systems. They comply with the EMC product standard EN 61800-3 "Variable-speed electrical drives". Provided that you comply with the installation instructions for the SEW components, the CE marking requirements for the entire machine/system in which they are installed are satisfied on the basis of the EMC directive 2004/108/EC. For detailed information on EMC compliant installation, refer to the publication "Electromagnetic Compatibility in Drive Engineering" from SEW-EURODRIVE.
- Compliance with limit classes C1, C2 or C3 has been tested in a CE-typical drive system. SEW-EURODRIVE can provide detailed information on request.



The CE-mark on the nameplate indicates conformity with the low voltage directive 2006/95/EC. We can provide a declaration of conformity on request.

2.1.2 UL- / cUL / GOST-R



UL, cUL approval (USA) and the GOST-R certificate (Russia) have been approved for the entire MOVIDRIVE® unit series. cUL is equivalent to CSA approval.

2.1.3 C-Tick



C-Tick approval has been granted for the entire MOVIDRIVE® range of units. C-Tick certifies conformity with ACMA (Australian Communications and Media Authority) standards.

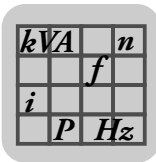

2.2 General technical data

The following table lists the technical data applicable to all MOVIDRIVE® MDX60B/61B inverters, regardless of their type, version, size and performance.

MOVIDRIVE® MDX60B/61B	All sizes
Interference immunity	Meets EN 61800-3
Interference emission with EMC compliant installation	Sizes 0 to 7 meet EN 61800-3 Sizes 0 to 5: According to limit value class C1 to 61800-3 with a corresponding line filter Sizes 0, 1, 2S, and 2 in accordance with limit value class C2 to EN 61800-3 without additional measures Size 6 and 7 in accordance with limit value class C2 to EN 61800-3 with corresponding line filter
Ambient temperature ϑ_U	0 °C...+50 °C at $I_D = 100\% I_N$ and $f_{PWM} = 4$ kHz / size 7: 2.5 kHz 0 °C...+40 °C at $I_D = 125\% I_N$ and $f_{PWM} = 4$ kHz / size 7: 2.5 kHz 0 °C...+40 °C at $I_D = 100\% I_N$ and $f_{PWM} = 8$ kHz / size 7: 4 kHz
I_N reduction Ambient temperature	2.5 % I_N per K between 40 °C - 50 °C 3 % I_N per K at 50 °C - 60 °C
Climate class	EN 60721-3-3, class 3K3
Storage temperature¹⁾ ϑ_L	-25 °C ... +70 °C (EN 60721-3-3, class 3K3) DBG keypad: -20 °C ... +60 °C
Cooling type (DIN 41751)	Forced cooling (temperature-controlled fan, response threshold 45 °C)
Degree of protection EN 60529 (NEMA1) Sizes 0 to 3 Sizes 4 to 6	IP20 IP00 (power connections) IP10 (power connections) with <ul style="list-style-type: none"> fitted Plexiglas cover supplied as standard and shrink tubing (not included in scope of delivery)
Size 7	IP00 (power connections) IP20 (plug connector) with <ul style="list-style-type: none"> installed DLB21B touch guard
Operating mode	Continuous operation with 50% overload capacity (size 0: 100 %)
Overvoltage category	III according to IEC 60664-1 (VDE 0110-1)
Pollution class	2 according to IEC 60664-1 (VDE 0110-1)
Protection against mechanically active substances	3S1
Protection against chemically active substances	3C2
Installation altitude h	Up to $h \leq 1000$ m (3281 ft) without restrictions. The following restrictions apply at $h \geq 1000$ m (3281 ft): <ul style="list-style-type: none"> from 1000 m (3281 ft) to max. 4000 m (13120 ft): <ul style="list-style-type: none"> I_N reduction by 1% per 100 m (328 ft) from 2000 m (6562 ft) to max. 4000 m (13120 ft): <ul style="list-style-type: none"> The safe disconnection of power and electronics connections can no longer be assured above 2000 m. This requires external measures (IEC60664-1 / EN61800-5-1) You have to connect an overvoltage protection device in order to reduce the overvoltages from category III to category II.

1) In case of long-term storage, connect the unit to the power supply for at least 5 minutes every two years, otherwise the unit's service life may be reduced.

kVA	n
	f
i	
P	Hz

2.2.1 MOVIDRIVE® MDX60/61B unit series, size 0

The following figure shows the MOVIDRIVE® MDX60/61B unit series, size 0



1940365835

2.2.2 MOVIDRIVE® MDX61B unit series, sizes 1 to 7

The following figure shows the MOVIDRIVE® MDX61B unit series, sizes 1 to 7



2059056779

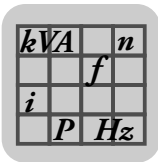

Technical Data of Basic Unit

MOVIDRIVE® MDX60/61B...-5_3 (AC 400/500 V units)

2.3 MOVIDRIVE® MDX60/61B...-5_3 (AC 400/500 V units)



2.3.1 Size 0

MOVIDRIVE® MDX60/61B		0005-5A3-4-0_	0008-5A3-4-0_	0011-5A3-4-0_	0014-5A3-4-0_
Size		0S		0M	
INPUT					
Nominal line voltage (to EN 50160)	V_{line}	3 × AC 380 V - 500 V			
Line frequency f_{line}		50 Hz ... 60 Hz ± 5%			
Nominal line current ¹⁾ (at $V_{line} = 3 \times AC\ 400\ V$)	I_{line} 100% 125 %	AC 1.8 A AC 2.3 A	AC 2.2 A AC 2.7 A	AC 2.8 A AC 3.5 A	AC 3.6 A AC 4.5 A
OUTPUT					
Apparent output power ²⁾ (at $V_{line} = 3 \times AC\ 380...500\ V$)	S_N	1.4 kVA	1.6 kVA	2.1 kVA	2.8 kVA
Rated output current ¹⁾ (at $V_{line} = 3 \times AC\ 400\ V$)	I_N	AC 2 A	AC 2.4 A	AC 3.1 A	AC 4 A
Continuous output current (= 125 % I_N) (at $V_{line} = 3 \times AC\ 400\ V$ and $f_{PWM} = 4\ kHz$)	I_D	AC 2.5 A	AC 3 A	AC 3.8 A	AC 5 A
Continuous output current (= 100 % I_N) (at $V_{line} = 3 \times AC\ 400\ V$ and $f_{PWM} = 8\ kHz$)	I_D	AC 2 A	AC 2.4 A	AC 3.1 A	AC 4 A
Current limitation	I_{max}	Motor and regenerative 200 % I_N , duration depending on capacity utilization			
Internal current limitation		$I_{max} = 0...200\ %$ adjustable			
Minimum permitted brake resistance value (4Q operation)	R_{BWmin}	68 Ω			
Output voltage	V_O	Max. V_{line}			
PWM frequency	f_{PWM}	Adjustable: 4/8/12/16 kHz			
Speed range/resolution	$n_A/\Delta n_A$	-6000 ... 0 ... +6000 min^{-1} / 0.2 min^{-1} across the entire range			
GENERAL INFORMATION					
Power loss at S_N ²⁾	P_{Vmax}	42 W	48 W	58 W	74 W
Cooling air consumption		3 m^3/h		9 m^3/h	
Cross section of unit terminals X1, X2, X3, X4		Terminal blocks 4 mm^2 conductor end sleeves DIN 46228			
Tightening torque		0.6 Nm			

1) The system and output currents must be reduced by 20% from the nominal values for $V_{line} = 3 \times AC\ 500\ V$.

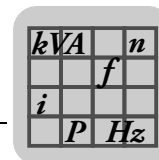
2) The performance data applies to $f_{PWM} = 4\ kHz$.



MDX61B standard version Variants with coated printed circuit boards	0005-5A3-4-00 0005-5A3-4-00/L	0008-5A3-4-00 0008-5A3-4-00/L	0011-5A3-4-00 0011-5A3-4-00/L	0014-5A3-4-00 0014-5A3-4-00/L
Part number	827 722 2 828 947 6	827 723 0 828 948 4	827 724 9 828 949 2	827 725 7 828 950 6
MDX61B Application version Variants with coated printed circuit boards	0005-5A3-4-0T 0005-5A3-4-0T/L	0008-5A3-4-0T 0008-5A3-4-0T/L	0011-5A3-4-0T 0011-5A3-4-0T/L	0014-5A3-4-0T 0014-5A3-4-0T/L
Part number	827 726 5 828 951 4	827 727 3 828 952 2	827 728 1 828 953 0	827 729 X 828 954 9
 Constant load Recommended motor power P_{Mot}	0.55 kW (0.74 HP)	0.75 kW (1.0 HP)	1.1 kW (1.5 HP)	1.5 kW (2.0 HP)
 Variable torque load or constant load without overload recommended motor power P_{Mot}	0.75 kW (1.0 HP)	1.1 kW (1.5 HP)	1.5 kW (2.0 HP)	2.2 kW (3.0 HP)
Mass	2.0 kg (4.4 lb)		2.5 kg (5.5 lb)	
Dimensions W × H × D	45 mm × 317 mm × 260 mm (1.8 in × 12.5 in × 10.2 in)		67,5 mm × 317 mm × 260 mm (2.66 in × 12.5 in × 10.2 in)	

MDX61B standard version (VFC/CFC/SERVO) Variants with coated printed circuit boards	0005-5A3-4-00 0005-5A3-4-00/L	0008-5A3-4-00 0008-5A3-4-00/L	0011-5A3-4-00 0011-5A3-4-00/L	0014-5A3-4-00 0014-5A3-4-00/L
Part number	827 730 3 828 955 7	827 731 1 828 956 5	827 732 X 828 957 3	827 733 8 828 958 1
MDX61B Application version (VFC/CFC/SERVO) Variants with coated printed circuit boards	0005-5A3-4-0T 0005-5A3-4-0T/L	0008-5A3-4-0T 0008-5A3-4-0T/L	0011-5A3-4-0T 0011-5A3-4-0T/L	0014-5A3-4-0T 0014-5A3-4-0T/L
MDX61B standard version (VFC/CFC/SERVO) Variants with coated printed circuit boards	0005-5A3-4-00 0005-5A3-4-00/L	0008-5A3-4-00 0008-5A3-4-00/L	0011-5A3-4-00 0011-5A3-4-00/L	0014-5A3-4-00 0014-5A3-4-00/L
Part number	827 734 6 828 960 3	827 735 4 828 961 1	827 736 2 828 963 8	827 737 0 828 964 6
Mass	2.3 kg (5.1 lb)		2.8 kg (6.2 lb)	
Dimensions W × H × D	72.5 mm × 317 mm × 260 mm (2.85 in × 12.5 in × 10.2 in)		95 mm × 317 mm × 260 mm (3.7 in × 12.5 in × 10.2 in)	
Recommended motor power	→ MOVIDRIVE® B system manual or catalog, chapter "Motor selection"			

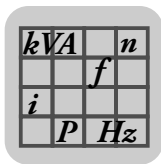

Technical Data of Basic Unit



MOVIDRIVE® MDX60/61B...-5_3 (AC 400/500 V units)

2.3.2 Size 1 (AC 400/500 V units)

MOVIDRIVE® MDX61B		0015-5A3-4-0_	0022-5A3-4-0_	0030-5A3-4-0_	0040-5A3-4-0_	
INPUT						
Nominal line voltage (to EN 50160)	V_{line}	3 × AC 380 V - 500 V				
Line frequency	f_{line}	50 Hz ... 60 Hz ± 5%				
Nominal line current ¹⁾ (at $V_{line} = 3 \times AC 400 V$)	I_{line}	100%	AC 3.6 A	AC 5.0 A	AC 6.3 A	AC 8.6 A
		125 %	AC 4.5 A	AC 6.2 A	AC 7.9 A	AC 10.7 A
OUTPUT						
Apparent output power ²⁾ (at $V_{line} = 3 \times AC 380...500 V$)	S_N	2.8 kVA	3.8 kVA	4.9 kVA	6.6 kVA	
Rated output current ¹⁾ (at $V_{line} = 3 \times AC 400 V$)	I_N	AC 4 A	AC 5.5 A	AC 7 A	AC 9.5 A	
Continuous output current (= 125 % I_N) (at $V_{line} = 3 \times AC 400 V$ and $f_{PWM} = 4 kHz$)	I_D	AC 5 A	AC 6.9 A	AC 8.8 A	AC 11.9 A	
Continuous output current (= 100 % I_N) (at $V_{line} = 3 \times AC 400 V$ and $f_{PWM} = 8 kHz$)	I_D	AC 4 A	AC 5.5 A	AC 7 A	AC 9.5 A	
Current limitation	I_{max}	Motor and regenerative 150 % I_N , duration depending on capacity utilization				
Internal current limitation		$I_{max} = 0...150$ % adjustable				
Minimum permitted brake resistance value (4Q operation)	R_{BWmin}	68 Ω				
Output voltage	V_O	Max. V_{line}				
PWM frequency	f_{PWM}	Adjustable: 4/8/12/16 kHz				
Speed range/resolution	$n_A/\Delta n_A$	-6000 ... 0 ... +6000 min ⁻¹ / 0.2 min ⁻¹ across the entire range				
GENERAL INFORMATION						
Power loss at S_N ²⁾	P_{Vmax}	85 W	105 W	130 W	180 W	
Cooling air consumption		40 m ³ /h				
Mass		3.5 kg (7.7 lb)				
Dimensions W × H × D		105 mm × 314 mm × 234 mm (4.13 in × 12.4 in × 9.21 in)				
Cross section of unit terminals X1, X2, X3, X4		Terminal blocks 4 mm ² conductor end sleeves DIN 46228				
Tightening torque		0.6 Nm				

1) The system and output currents must be reduced by 20% from the nominal values for $V_{line} = 3 \times AC 500 V$.

2) The performance data applies to $f_{PWM} = 4 kHz$.

MDX61B Standard version	0015-5A3-4-00	0022-5A3-4-00	0030-5A3-4-00	0040-5A3-4-00
Variants with coated printed circuit boards	0015-5A3-4-00/L	0022-5A3-4-00/L	0030-5A3-4-00/L	0040-5A3-4-00/L
Part number	827 957 8 1840 013 2	827 958 6 1840 014 0	827 959 4 1840 015 9	827 960 8 1840 016 7
MDX61B Application version	0015-5A3-4-0T	0022-5A3-4-0T	0030-5A3-4-0T	0040-5A3-4-0T
Variants with coated printed circuit boards	0015-5A3-4-0T/L	0022-5A3-4-0T/L	0030-5A3-4-0T/L	0040-5A3-4-0T/L
Part number	827 975 6 1840 031 0	827 976 4 1840 032 9	827 977 2 1840 033 7	827 978 0 1840 034 5
 Constant load Recommended motor power P_{Mot}	1.5 kW (2.0 HP)	2.2 kW (3.0 HP)	3.0 kW (4.0 HP)	4.0 kW (5.4 HP)
 Variable torque load or constant load without overload recommended motor power P_{Mot}	2.2 kW (3.0 HP)	3.0 kW (4.0 HP)	4.0 kW (5.4 HP)	5.5 kW (7.4 HP)
Recommended motor power	→ MOVIDRIVE® B system manual or catalog, chapter "Motor selection"			

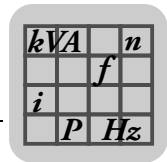



2.3.3 Sizes 2S and 2 (AC 400/500 V units)

MOVIDRIVE® MDX61B	0055-5A3-4-0_	0075-5A3-4-0_	0110-5A3-4-0_
Size	2S		2
INPUT			
Nominal line voltage (to EN 50160)	V_{line}	3 × AC 380 V - 500 V	
Line frequency	f_{line}	50 Hz ... 60 Hz ± 5%	
Nominal line current ¹⁾ (at $V_{line} = 3 \times AC\ 400\ V$)	I_{line}	100%	AC 11.3 A
		125 %	AC 14.1 A
		AC 14.4 A	AC 21.6 A
		AC 18.0 A	AC 27.0 A
OUTPUT			
Apparent output power ²⁾ (at $V_{line} = 3 \times AC\ 380...500\ V$)	S_N	8.7 kVA	11.2 kVA
			16.8 kVA
Rated output current ¹⁾ (at $V_{line} = 3 \times AC\ 400\ V$)	I_N	AC 12.5 A	AC 16 A
			AC 24 A
Continuous output current (= 125 % I_N) (at $V_{line} = 3 \times AC\ 400\ V$ with $f_{PWM} = 4\ kHz$)	I_D	AC 15.6 A	AC 20 A
			AC 30 A
Continuous output current (= 100 % I_N) (at $V_{line} = 3 \times AC\ 400\ V$ with $f_{PWM} = 8\ kHz$)	I_D	AC 12.5 A	AC 16 A
			AC 24 A
Current limitation	I_{max}	Motor and regenerative 150 % I_N , duration depending on capacity utilization	
Internal current limitation		$I_{max} = 0...150\ %$ adjustable	
Minimum permitted brake resistance value (4Q operation)	R_{BWmin}	47 Ω	22 Ω
Output voltage	V_O	Max. V_{line}	
PWM frequency	f_{PWM}	Adjustable: 4/8/12/16 kHz	
Speed range/resolution	$n_A/\Delta n_A$	-6000 ... 0 ... +6000 min ⁻¹ / 0.2 min ⁻¹ across the entire range	
GENERAL INFORMATION			
Power loss at S_N ²⁾	P_{Vmax}	220 W	290 W
			400 W
Cooling air consumption		80 m ³ /h	
Mass		6.6 kg (15 lb)	
Dimensions W × H × D		105 mm × 335 mm × 294 mm (4.13 in × 13.2 in × 11.6 in)	135 mm × 315 mm × 285 mm (5.31 in × 12.4 in × 11.2 in)
Cross section of unit terminals X1, X2, X3, X4		Terminal blocks 4 mm ² conductor end sleeves DIN 46228	M4 screw and washer assembly with terminal clip 4 mm ² conductor end sleeve DIN 46228 6 mm ² crimp cable lug DIN 46234
Tightening torque		0.6 Nm	1.5 Nm

1) The system and output currents must be reduced by 20% from the nominal values for $V_{line} = 3 \times AC\ 500\ V$.

2) The performance data applies to $f_{PWM} = 4\ kHz$.

MDX61B Standard version	0055-5A3-4-00	0075-5A3-4-00	0110-5A3-4-00
Variants with coated printed circuit boards	0055-5A3-4-00/L	0075-5A3-4-00/L	0110-5A3-4-00/L
Part number	827 961 6 1840 017 5	827 962 4 1840 018 3	827 963 2 1840 019 1
MDX61B Application version	0055-5A3-4-0T	0075-5A3-4-0T	0110-5A3-4-0T
Variants with coated printed circuit boards	0055-5A3-4-0T/L	0075-5A3-4-0T/L	0110-5A3-4-0T/L
Part number	827 979 9 1840 035 3	827 980 2 1840 036 1	827 981 0 1840 038 8
 Constant load Recommended motor power P_{Mot}	5.5 kW (7.4 HP)	7.5 kW (10 HP)	11 kW (15 HP)
 Variable torque load or constant load without overload recommended motor power P_{Mot}	7.5 kW (10 HP)	11 kW (15 HP)	15 kW (20 HP)
Recommended motor power	→ MOVIDRIVE® B system manual or catalog, chapter "Motor selection"		

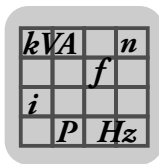

Technical Data of Basic Unit



MOVIDRIVE® MDX60/61B...-5_3 (AC 400/500 V units)

2.3.4 Size 3 (AC 400/500 V units)

MOVIDRIVE® MDX61B		0150-503-4-0_	0220-503-4-0_	0300-503-4-0_
INPUT				
Nominal line voltage (to EN 50160)	V_{line}	3 × AC 380 V - 500 V		
Line frequency	f_{line}	50 Hz ... 60 Hz ± 5%		
Nominal line current ¹⁾ (at $V_{line} = 3 \times AC 400 V$)	I_{line}	100% AC 28.8 A	AC 41.4 A	AC 54 A
		125 % AC 36 A	AC 51.7 A	AC 67.5 A
OUTPUT				
Apparent output power ²⁾ (at $V_{line} = 3 \times AC 380...500 V$)	S_N	22.2 kVA	31.9 kVA	41.6 kVA
Rated output current ¹⁾ (at $V_{line} = 3 \times AC 400 V$)	I_N	AC 32 A	AC 46 A	AC 60 A
Continuous output current (= 125 % I_N) (at $V_{line} = 3 \times AC 400 V$ with $f_{PWM} = 4 kHz$)	I_D	AC 40 A	AC 57.5 A	AC 75 A
Continuous output current (= 100 % I_N) (at $V_{line} = 3 \times AC 400 V$ with $f_{PWM} = 8 kHz$)	I_D	AC 32 A	AC 46 A	AC 60 A
Current limitation	I_{max}	Motor and regenerative 150 % I_N , duration depending on capacity utilization		
Internal current limitation		$I_{max} = 0...150\%$ adjustable		
Minimum permitted brake resistance value (4Q operation)	R_{BWmin}	15 Ω		12 Ω
Output voltage	V_O	Max. V_{line}		
PWM frequency	f_{PWM}	Adjustable: 4/8/12/16 kHz		
Speed range/resolution	$n_A/\Delta n_A$	-6000 ... 0 ... +6000 min ⁻¹ / 0.2 min ⁻¹ across the entire range		
GENERAL INFORMATION				
Power loss at S_N ²⁾	P_{Vmax}	550 W	750 W	950 W
Cooling air consumption		180 m ³ /h		
Mass		15.0 kg (33 lb)		
Dimensions W × H × D		200 mm × 465 mm × 308 mm (7.87 in × 18.3 in × 12.1 in)		
Cross section of unit terminals X1, X2, X3, X4		M6 screw with washer max. 25 mm ² Crimp cable lug DIN 46234		
Tightening torque		3.5 Nm		

1) The system and output currents must be reduced by 20% from the nominal values for $V_{line} = 3 \times AC 500 V$.

2) The performance data applies to $f_{PWM} = 4 kHz$.

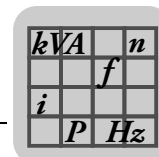

MDX61B Standard version	0150-503-4-00	0220-503-4-00	0300-503-4-00
Variants with coated printed circuit boards	0150-503-4-00/L	0220-503-4-00/L	0300-503-4-00/L
Part number	827 964 0 1840 020 5	827 965 9 1840 021 3	827 966 7 1840 022 1
MDX61B Application version	0150-503-4-0T	0220-503-4-0T	0300-503-4-0T
Variants with coated printed circuit boards	0150-503-4-0T/L	0220-503-4-0T/L	0300-503-4-0T/L
Part number	827 982 9 1840 039 6	827 983 7 1840 041 8	827 984 5 1840 042 6
 Constant load Recommended motor power P_{Mot}	15 kW (20 HP)	22 kW (30 HP)	30 kW (40 HP)
 Variable torque load or constant load without overload recommended motor power P_{Mot}	22 kW (30 HP)	30 kW (40 HP)	37 kW (50 HP)
Recommended motor power	→ MOVIDRIVE® B system manual or catalog, chapter "Motor selection"		



2.3.5 Size 4 (AC 400/500 V units)

MOVIDRIVE® MDX61B	0370-503-4-0_	0450-503-4-0_
INPUT		
Nominal line voltage (to EN 50160)	V_{line}	3 × AC 380 V - 500 V
Line frequency	f_{line}	50 Hz ... 60 Hz ± 5%
Nominal line current ¹⁾ (at $V_{line} = 3 \times AC 400 V$)	I_{line}	100% AC 65.7 A 125 % AC 81.9 A
OUTPUT		
Apparent output power ²⁾ (at $V_{line} = 3 \times AC 380...500 V$)	S_N	51.1 kVA 62.3 kVA
Rated output current ¹⁾ (at $V_{line} = 3 \times AC 400 V$)	I_N	AC 73 A AC 89 A
Continuous output current (= 125 % I_N) (at $V_{line} = 3 \times AC 400 V$ with $f_{PWM} = 4 kHz$)	I_D	AC 91 A AC 111 A
Continuous output current (= 100 % I_N) (at $V_{line} = 3 \times AC 400 V$ with $f_{PWM} = 8 kHz$)	I_D	AC 73 A AC 89 A
Current limitation	I_{max}	Motor and regenerative 150 % I_N , duration depending on capacity utilization
Internal current limitation		$I_{max} = 0...150\%$ adjustable
Minimum permitted brake resistance value (4Q operation)	R_{BWmin}	6 Ω
Output voltage	V_O	Max. V_{line}
PWM frequency	f_{PWM}	Adjustable: 4/8/12/16 kHz
Speed range/resolution	$n_A/\Delta n_A$	-6000 ... 0 ... +6000 min ⁻¹ / 0.2 min ⁻¹ across the entire range
GENERAL INFORMATION		
Power loss at S_N ²⁾	P_{Vmax}	1200 W 1450 W
Cooling air consumption		180 m ³ /h
Mass		27 kg (60 lb)
Dimensions W × H × D		280 mm × 522 mm × 307 mm (11.0 in × 20.6 in × 12.1 in)
Cross section of unit terminals X1, X2, X3, X4		M10 bolt with nut Max. 70 mm ² Press cable lug DIN 46235
Tightening torque		14 Nm

- 1) The system and output currents must be reduced by 20% from the nominal values for $V_{line} = 3 \times AC 500 V$.
 2) The performance data applies to $f_{PWM} = 4 kHz$.

MDX61B Standard version	0370-503-4-00	0450-503-4-00
Variants with coated printed circuit boards	0370-503-4-00/L	0450-503-4-00/L
Part number	827 967 5 1840 024 8	827 968 3 1840 025 6
MDX61B Application version	0370-503-4-0T	0450-503-4-0T
Variants with coated printed circuit boards	0370-503-4-0T/L	0450-503-4-0T/L
Part number	827 985 3 1840 043 4	827 986 1 1840 044 2
 Constant load Recommended motor power P_{Mot}	37 kW (50 HP)	45 kW (60 HP)
 Variable torque load or constant load without overload recommended motor power P_{Mot}	45 kW (60 HP)	55 kW (74 HP)
Recommended motor power	→ MOVIDRIVE® B system manual or catalog, chapter "Motor selection"	

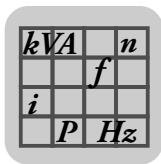

Technical Data of Basic Unit



MOVIDRIVE® MDX60/61B...-5_3 (AC 400/500 V units)

2.3.6 Size 5 (AC 400/500 V units)

MOVIDRIVE® MDX61B		0550-503-4-0_	0750-503-4-0_
INPUT			
Nominal line voltage (to EN 50160)	V_{line}	3 × AC 380 V - 500 V	
Line frequency	f_{line}	50 Hz ... 60 Hz ± 5%	
Nominal line current ¹⁾ (at $V_{line} = 3 \times AC 400 V$)	I_{line}	100% AC 94.5 A	AC 117 A
		125 % AC 118.1 A	AC 146.3 A
OUTPUT			
Apparent output power ²⁾ (at $V_{line} = 3 \times AC 380...500 V$)	S_N	73.5 kVA	91.0 kVA
Rated output current ¹⁾ (at $V_{line} = 3 \times AC 400 V$)	I_N	AC 105 A	AC 130 A
Continuous output current (= 125 % I_N) (at $V_{line} = 3 \times AC 400 V$ with $f_{PWM} = 4 kHz$)	I_D	AC 131 A	AC 162 A
Continuous output current (= 100 % I_N) (at $V_{line} = 3 \times AC 400 V$ with $f_{PWM} = 8 kHz$)	I_D	AC 105 A	AC 130 A
Current limitation	I_{max}	Motor and regenerative 150 % I_N , duration depending on capacity utilization	
Internal current limitation		$I_{max} = 0...150\%$ adjustable	
Minimum permitted brake resistance value (4Q operation)	R_{BWmin}	6 Ω	4 Ω
Output voltage	V_O	Max. V_{line}	
PWM frequency	f_{PWM}	Adjustable: 4/8/12/16 kHz	
Speed range/resolution	$n_A/\Delta n_A$	-6000 ... 0 ... +6000 min^{-1} / 0.2 min^{-1} across the entire range	
GENERAL INFORMATION			
Power loss at S_N ²⁾	P_{Vmax}	1700 W	2000 W
Cooling air consumption		360 m^3/h	
Mass		35 kg (77 lb)	
Dimensions W × H × D		280 mm × 610 mm × 330 mm (11.0 in × 24.0 in × 13.0 in)	
Cross section of unit terminals X1, X2, X3, X4		M10 bolt with nut Max. 70 mm^2 Press cable lug DIN 46235	
Tightening torque		14 Nm	

1) The system and output currents must be reduced by 20% from the nominal values for $V_{line} = 3 \times AC 500 V$.

2) The performance data applies to $f_{PWM} = 4 kHz$.

MDX61B Standard version	0550-503-4-00	0750-503-4-00
Variants with coated printed circuit boards	0550-503-4-00/L	0750-503-4-00/L
Part number	827 969 1 1840 026 4	827 970 5 1840 027 2
MDX61B Application version	0550-503-4-0T	0750-503-4-0T
Variants with coated printed circuit boards	0550-503-4-0T/L	0750-503-4-0T/L
Part number	827 988 8 1840 045 0	827 989 6 1840 046 9
 Constant load Recommended motor power P_{Mot}	55 kW (74 HP)	75 kW (100 HP)
 Variable torque load or constant load without overload recommended motor power P_{Mot}	75 kW (100 HP)	90 kW (120 HP)
Recommended motor power	→ MOVIDRIVE® B system manual or catalog, chapter "Motor selection"	

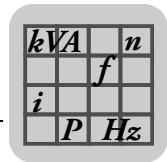



2.3.7 Size 6 (AC 400/500 V units)

MOVIDRIVE® MDX61B		0900-503-4-0_	1100-503-4-0_	1320-503-4-0_
INPUT				
Nominal line voltage (to EN 50160)	V_{line}	3 × AC 380 V - 500 V		
Line frequency	f_{line}	50 Hz ... 60 Hz ± 5%		
Nominal line current ¹⁾ (at $V_{line} = 3 \times AC\ 400\ V$) 125 %	I_{line} 100%	AC 153 A AC 191 A	AC 180 A AC 225 A	AC 225 A AC 281 A
OUTPUT				
Apparent output power ²⁾ (at $V_{line} = 3 \times AC\ 380...500\ V$)	S_N	118 kVA	139 kVA	174 kVA
Rated output current ¹⁾ (at $V_{line} = 3 \times AC\ 400\ V$)	I_N	AC 170 A	AC 200 A	AC 250 A
Continuous output current (= 125 % I_N) (at $V_{line} = 3 \times AC\ 400\ V$ with $f_{PWM} = 4\ kHz$)	I_D	AC 212 A	AC 250 A	AC 312 A
Continuous output current (= 100 % I_N) (at $V_{line} = 3 \times AC\ 400\ V$ with $f_{PWM} = 4\ kHz$) Temperature range 0 °C ... +50 °C	I_D	AC 170 A	AC 200 A	AC 250 A
Current limitation	I_{max}	Motor and regenerative 150 % I_N , duration depending on capacity utilization		
Internal current limitation		$I_{max} = 0...150\ %$ adjustable		
Minimum permitted brake R_{BWmin} resistance value (4Q operation)		2.7 Ω		
Output voltage	V_O	Max. V_{line}		
PWM frequency	f_{PWM}	Adjustable: 4 or 8 kHz		
Speed range/resolution	$n_A/\Delta n_A$	-6000 ... 0 ... +6000 min^{-1} / 0.2 min^{-1} across the entire range		
GENERAL INFORMATION				
Power loss at S_N ²⁾	P_{Vmax}	2300 W	2500 W	2700 W
Cooling air consumption		600 m ³ /h		
Mass		60 kg (130 lb)		
Dimensions W × H × D		280 mm × 1000 mm × 382 mm (11.0 in × 39.37 in × 15.0 in)		
Cross section of unit terminals X1, X2, X3, X4		M12 bolt with nut Max. 185 mm ² Press cable lug DIN 46235		
Tightening torque		20 Nm		

1) The system and output currents must be reduced by 20% from the nominal values for $V_{line} = 3 \times AC\ 500\ V$.

2) The performance data applies to $f_{PWM} = 4\ kHz$.

MDX61B Standard version	0900-503-4-00	1100-503-4-00	1320-503-4-00
Variants with coated printed circuit boards	0900-503-4-00/L	1100-503-4-00/L	1320-503-4-00/L
Part number	827 971 3 1840 028 0	827 972 1 1840 029 9	827 974 8 1840 030 2
MDX61B Application version	0900-503-4-0T	1100-503-4-0T	1320-503-4-0T
Variants with coated printed circuit boards	0900-503-4-0T/L	1100-503-4-0T/L	1320-503-4-0T/L
Part number	827 991 8 1840 047 7	827 992 6 1840 048 5	827 993 4 1840 049 3
 Constant load Recommended motor power P_{Mot}	90 kW (120 HP)	110 kW (148 HP)	132 kW (177 HP)
 Variable torque load or constant load without overload recommended motor power P_{Mot}	110 kW (148 HP)	132 kW (177 HP)	160 kW (215 HP)
Recommended motor power	→ MOVIDRIVE® B system manual or catalog, chapter "Motor selection"		

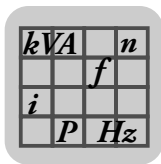

Technical Data of Basic Unit



MOVIDRIVE® MDX60/61B...-5_3 (AC 400/500 V units)

2.3.8 Size 7 (AC 400/500 V units)

MOVIDRIVE® MDX61B		1600-503-2-0T/L 1600-503-4-0T/L	2000-503-2-0T/L 2000-503-4-0T/L	2500-503-2-0T/L 2500-503-4-0T/L
INPUT				
Nominal line voltage (to EN 50160)	V_{line}	3 × AC 380 V - 500 V		
Line frequency	f_{line}	50 Hz ... 60 Hz ± 5%		
Nominal line current ¹⁾ (at $V_{line} = 3 \times AC\ 400\ V$)	I_{line}	100%	AC 280 A	AC 340 A
		125 %	AC 340 A	AC 425 A
OUTPUT				
Apparent output power ²⁾ (at $V_{line} = 3 \times AC\ 380...500\ V$)	S_N	208 kVA	263 kVA	326 kVA
Rated output current ¹⁾ (at $V_{line} = 3 \times AC\ 400\ V$)	I_N	AC 300 A	AC 380 A	AC 470 A
Continuous output current (= 125 % I_N) (at $V_{line} = 3 \times AC\ 400\ V$ with $f_{PWM} = 2.5\ kHz$)	I_D	AC 375 A	AC 475 A	AC 588 A
Continuous output current (= 100 % I_N) (at $V_{line} = 3 \times AC\ 400\ V$ with $f_{PWM} = 2.5\ kHz$)	I_D	AC 300 A	AC 380 A	AC 470 A
Temperature range 0 °C ... +50 °C				
Current limitation	I_{max}	Motor and regenerative 150 % I_N , duration depending on capacity utilization		
Internal current limitation		$I_{max} = 0...150\ %$ adjustable		
Minimum permitted brake resistance value (4Q operation)	R_{BWmin}	1.1 Ω		
Output voltage	V_O	Max. V_{line}		
PWM frequency	f_{PWM}	Adjustable: 2.5 or 4 kHz		
Speed range/resolution	$n_A/\Delta n_A$	-6000 ... 0 ... +6000 min ⁻¹ / 0.2 min ⁻¹ across the entire range		
GENERAL INFORMATION				
Power loss at S_N ²⁾	P_{Vmax}	3000 W	3600 W	4400 W
Cooling air consumption		1200 m ³ /h		
Mass		2Q variant: 260 kg (573 lb) 4Q variant: 280 kg (617 lb)		
Dimensions W × H × D		700 mm × 1490 mm × 470 mm (27.6 in × 58.7 in × 18.5 in)		
Conductor rails X1, X2, X3		Connection rail with bore for M12 Max. 2 × 240 mm ² Press cable lug DIN 46235		
Tightening torque		70 Nm (620 lb in)		

1) The system and output currents must be reduced by 20% from the nominal values for $V_{line} = 3 \times AC\ 500\ V$.

2) The performance data applies to $f_{PWM} = 2.5\ kHz$.

MDX61B Application version With coated printed circuit boards	1600-503-2-0T/L 1600-503-4-0T/L	2000-503-2-0T/L 2000-503-4-0T/L	2500-503-2-0T/L 2500-503-4-0T/L
Part number	829 976 5 829 980 3	829 977 3 829 981 1	829 978 1 829 983 8
 Constant load Recommended motor power P_{Mot}	160 kW (215 HP)	200 kW (268 HP)	250 kW (335 HP)
 Variable torque load or constant load without overload Recommended motor power P_{Mot}	200 kW (268 HP)	250 kW (335 HP)	315 kW (422 HP)
Recommended motor power	→ MOVIDRIVE® B system manual or catalog, chapter "Motor selection"		

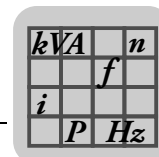



2.4 MOVIDRIVE® MDX61B...-2_3 (AC 230 V units)

2.4.1 Size 1 (AC 230 V units)

MOVIDRIVE® MDX61B		0015-2A3-4-0_	0022-2A3-4-0_	0037-2A3-4-0_
INPUT				
Nominal line voltage (to EN 50160)	V_{line}	3 × AC 200 V - 240 V		
Line frequency	f_{line}	50 Hz ... 60 Hz ± 5%		
Rated line current (at $V_{line} = 3 \times AC\ 230\ V$)125 %	I_{line} 100 %	AC 6.7 A AC 8.4 A	AC 7.8 A AC 9.8 A	AC 12.9 A AC 16.1 A
OUTPUT				
Apparent output power ¹⁾ (at $V_{line} = 3 \times AC\ 230...240\ V$)	S_N	2.7 kVA	3.4 kVA	5.8 kVA
Nominal output current (at $V_{line} = 3 \times AC\ 230\ V$)	I_N	AC 7.3 A	AC 8.6 A	AC 14.5 A
Continuous output current (= 125 % I_N) (at $V_{line} = 3 \times AC\ 230\ V$ with $f_{PWM} = 4\ kHz$)	I_D	AC 9.1 A	AC 10.8 A	AC 18.1 A
Continuous output current (= 100 % I_N) (at $V_{line} = 3 \times AC\ 230\ V$ with $f_{PWM} = 8\ kHz$)	I_D	AC 7.3 A	AC 8.6 A	AC 14.5 A
Current limitation	I_{max}	Motor and regenerative 150 % I_N , duration depending on capacity utilization		
Internal current limitation		$I_{max} = 0...150\ %$ adjustable		
Minimum permitted brake resistance value (4Q operation)	R_{BWmin}	27 Ω		
Output voltage	V_O	Max. V_{line}		
PWM frequency	f_{PWM}	Adjustable: 4/8/12/16 kHz		
Speed range/resolution	$n_A/\Delta n_A$	-6000 ... 0 ... +6000 min^{-1} / 0.2 min^{-1} across the entire range		
GENERAL INFORMATION				
Power loss at S_N ¹⁾	P_{Vmax}	110 W	126 W	210 W
Cooling air consumption		40 m^3/h		
Mass		2.8 kg (6.2 lb)		
Dimensions W × H × D		105 mm × 314 mm × 234 mm (4.13 in × 12.4 in × 9.21 in)		
Cross section of unit terminals X1, X2, X3, X4		Separable terminal strip 4 mm^2 conductor end sleeve DIN 46228		
Tightening torque		0.6 Nm		

1) The performance data applies to $f_{PWM} = 4\ kHz$.

MDX61B Standard version	0015-2A3-4-00	0022-2A3-4-00	0037-2A3-4-00
Part number	827 994 2	827 995 0	827 996 9
MDX61B Application version	0015-2A3-4-0T	0022-2A3-4-0T	0037-2A3-4-0T
Part number	828 003 7	828 004 5	828 005 3
 Constant load Recommended motor power P_{Mot}	1.5 kW (2.0 HP)	2.2 kW (3.0 HP)	3.7 kW (5.0 HP)
 Variable torque load or constant load without overload recommended motor power P_{Mot}	2.2 kW (3.0 HP)	3.7 kW (5.0 HP)	5.0 kW (6.7 HP)
Recommended motor power	→ MOVIDRIVE® B system manual, section "Motor selection"		

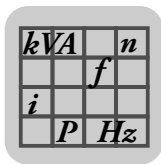



Technical Data of Basic Unit

MOVIDRIVE® MDX61B...-2_3 (AC 230 V units)

2.4.2 Size 2 (AC 230 V units)

MOVIDRIVE® MDX61B		0055-2A3-4-0_	0075-2A3-4-0_
INPUT			
Nominal line voltage (to EN 50160)	V_{line}	3 × AC 200 V - 240 V	
Line frequency	f_{line}	50 Hz ... 60 Hz ± 5%	
Rated line current (at $V_{line} = 3 \times AC\ 230\ V$)	I_{line}	100 % AC 19.5 A 125 % AC 24.4 A	AC 27.4 A AC 34.3 A
OUTPUT			
Apparent output power ¹⁾ (at $V_{line} = 3 \times AC\ 230...240\ V$)	S_N	8.8 kVA	11.6 kVA
Nominal output current (at $V_{line} = 3 \times AC\ 230\ V$)	I_N	AC 22 A	AC 29 A
Continuous output current (= 125 % I_N) (at $V_{line} = 3 \times AC\ 230\ V$ with $f_{PWM} = 4\ kHz$)	I_D	AC 27.5 A	AC 36.3 A
Continuous output current (= 100 % I_N) (at $V_{line} = 3 \times AC\ 230\ V$ with $f_{PWM} = 8\ kHz$)	I_D	AC 22 A	AC 29 A
Current limitation	I_{max}	Motor and regenerative 150 % I_N , duration depending on capacity utilization	
Internal current limitation		$I_{max} = 0...150\ %$ adjustable	
Minimum permitted brake resistance value (4Q operation)	R_{BWmin}	12 Ω	
Output voltage	V_O	Max. V_{line}	
PWM frequency	f_{PWM}	Adjustable: 4/8/12/16 kHz	
Speed range/resolution	$n_A/\Delta n_A$	-6000 ... 0 ... +6000 min^{-1} / 0.2 min^{-1} across the entire range	
GENERAL INFORMATION			
Power loss at S_N ¹⁾	P_{Vmax}	300 W	380 W
Cooling air consumption		80 m^3/h	
Mass		5.9 kg (13 lb)	
Dimensions W × H × D		135 mm × 315 mm × 285 mm (5.31 in × 12.4 in × 11.2 in)	
Cross section of unit terminals X1, X2, X3, X4		M4 screw and washer assembly with terminal clip 4 mm^2 conductor end sleeve DIN 46228 6 mm^2 crimp cable lug DIN 46234	
Tightening torque		1.5 Nm	

1) The performance data applies to $f_{PWM} = 4\ kHz$.

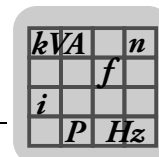

MDX61B Standard version	0055-2A3-4-00	0075-2A3-4-00
Part number	827 997 7	827 998 5
MDX61B Application version	0055-2A3-4-0T	0075-2A3-4-0T
Part number	828 006 1	828 008 8
 Constant load Recommended motor power P_{Mot}	5.5 kW (7.4 HP)	7.5 kW (10 HP)
 Variable torque load or constant load without overload recommended motor power P_{Mot}	7.5 kW (10 HP)	11 kW (15 HP)
Recommended motor power	→ MOVIDRIVE® B system manual, section "Motor selection"	



2.4.3 Size 3 (AC 230 V units)

MOVIDRIVE® MDX61B		0110-203-4-0_	0150-203-4-0_
INPUT			
Nominal line voltage (to EN 50160)	V_{line}	3 × AC 200 V - 240 V	
Line frequency	f_{line}	50 Hz ... 60 Hz ± 5%	
Rated line current (at $V_{line} = 3 \times AC\ 230\ V$)	I_{line}	100 % AC 40 A	AC 49 A
		125 % AC 50 A	AC 61 A
OUTPUT			
Apparent output power ¹⁾ (at $V_{line} = 3 \times AC\ 230...240\ V$)	S_N	17.1 kVA	21.5 kVA
Nominal output current (at $V_{line} = 3 \times AC\ 230\ V$)	I_N	AC 42 A	AC 54 A
Continuous output current (= 125 % I_N) I_D (at $V_{line} = 3 \times AC\ 230\ V$ with $f_{PWM} = 4\ kHz$)		AC 52.5 A	AC 67.5 A
Continuous output current (= 100 % I_N) I_D (at $V_{line} = 3 \times AC\ 230\ V$ with $f_{PWM} = 8\ kHz$)		AC 42 A	AC 54 A
Current limitation	I_{max}	Motor and regenerative 150 % I_N , duration depending on capacity utilization	
Internal current limitation		$I_{max} = 0...150\ %$ adjustable	
Minimum permitted brake resistance value (4Q operation)	R_{BWmin}	7.5 Ω	5.6 Ω
Output voltage	V_O	Max. V_{line}	
PWM frequency	f_{PWM}	Adjustable: 4/8/12/16 kHz	
Speed range/resolution	$n_A/\Delta n_A$	-6000 ... 0 ... +6000 min^{-1} / 0.2 min^{-1} across the entire range	
GENERAL INFORMATION			
Power loss at S_N ¹⁾	P_{Vmax}	580 W	720 W
Cooling air consumption		180 m ³ /h	
Mass		14.3 kg (31.5 lb)	
Dimensions W × H × D		200 mm × 465 mm × 308 mm (7.87 in × 18.3 in × 12.1 in)	
Cross section of unit terminals X1, X2, X3, X4		M6 screw and washer assembly with washer max. 25 mm ² Crimp cable lug DIN 46234	
Tightening torque		3.5 Nm	

1) The performance data applies to $f_{PWM} = 4\ kHz$.

MDX61B Standard version	0110-203-4-00	0150-203-4-00
Part number	827 999 3	828 000 2
MDX61B Application version	0110-203-4-0T	0150-203-4-0T
Part number	828 009 6	828 011 8
 Constant load Recommended motor power P_{Mot}	11 kW (15 HP)	15 kW (20 HP)
 Variable torque load or constant load without overload recommended motor power P_{Mot}	15 kW (20 HP)	22 kW (30 HP)
Recommended motor power	→ MOVIDRIVE® B system manual, section "Motor selection"	

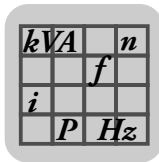



Technical Data of Basic Unit

MOVIDRIVE® MDX61B...-2_3 (AC 230 V units)

2.4.4 Size 4 (AC 230 V units)

MOVIDRIVE® MDX61B		0220-203-4-0_	0300-203-4-0_
INPUT			
Nominal line voltage (to EN 50160)	V_{line}	3 × AC 200 V - 240 V	
Line frequency	f_{line}	50 Hz ... 60 Hz ± 5%	
Rated line current (at $V_{line} = 3 \times AC\ 230\ V$)	I_{line}	100 % AC 72 A	AC 86 A
		125 % AC 90 A	AC 107 A
OUTPUT			
Apparent output power ¹⁾ (at $V_{line} = 3 \times AC\ 230...240\ V$)	S_N	31.8 kVA	37.8 kVA
Nominal output current (at $V_{line} = 3 \times AC\ 230\ V$)	I_N	AC 80 A	AC 95 A
Continuous output current (= 125 % I_N) I_D (at $V_{line} = 3 \times AC\ 230\ V$ with $f_{PWM} = 4\ kHz$)		AC 100 A	AC 118 A
Continuous output current (= 100 % I_N) I_D (at $V_{line} = 3 \times AC\ 230\ V$ with $f_{PWM} = 4\ kHz$)		AC 80 A	AC 95 A
Current limitation	I_{max}	Motor and regenerative 150 % I_N , duration depending on capacity utilization	
Internal current limitation		$I_{max} = 0...150\ %$ adjustable	
Minimum permitted brake resistance value (4Q operation)	R_{BWmin}	3 Ω	
Output voltage	V_O	Max. V_{line}	
PWM frequency	f_{PWM}	Adjustable: 4/8/12/16 kHz	
Speed range/resolution	$n_A/\Delta n_A$	-6000 ... 0 ... +6000 min ⁻¹ / 0.2 min ⁻¹ across the entire range	
GENERAL INFORMATION			
Power loss at S_N ¹⁾	P_{Vmax}	1100 W	1300 W
Cooling air consumption		180 m ³ /h	
Mass		26.3 kg (57 lb)	
Dimensions W × H × D		280 mm × 522 mm × 307mm (11.0 in × 20.6 in × 12.1 in)	
Cross section of unit terminals X1, X2, X3, X4		M10 bolt with nut max. 70 mm ² Press cable lug DIN 46235	
Tightening torque		3.5 Nm	

1) The performance data applies to $f_{PWM} = 4\ kHz$.

MDX61B Standard version	0220-203-4-00	0300-203-4-00
Part number	828 001 0	828 002 9
MDX61B Application version	0220-203-4-0T	0300-203-4-0T
Part number	828 012 6	828 013 4
 Constant load Recommended motor power P_{Mot}	22 kW (30 HP)	30 kW (40 HP)
 Variable torque load or constant load without overload recommended motor power P_{Mot}	30 kW (40 HP)	37 kW (50 HP)
Recommended motor power	→ MOVIDRIVE® B system manual, section "Motor selection"	

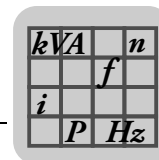

2.5 MOVIDRIVE® MDX60/61B electronics data

MOVIDRIVE® MDX60/61B		General electronics data	
Voltage supply for setpoint input	X11:1 X11:5	REF1: DC+10 V +5 % / -0 %, $I_{max} = DC 3 \text{ mA}$ REF2: DC-10 V +0 % / -5 %, $I_{max} = DC 3 \text{ mA}$	Reference voltages for setpoint potentiometer
Setpoint input n1 (differential input) Operating mode AI11/AI12 Resolution Internal resistance	X11:2/X11:3	AI11/AI12: Voltage or current input, can be set with S11 and P11_, sampling interval 1 ms Voltage input: n1 = DC 0...+10 V or DC -10 V...0...+10 V 12 bit $R_i = 40 \text{ k}\Omega$ (external voltage supply) $R_i = 20 \text{ k}\Omega$ (supply from REF1/REF2)	Current input: n1 = DC 0...20 mA or DC 4...20 mA 11 bit $R_i = 250 \Omega$
Internal setpoints		Parameter set 1: n11/n12/n13 = -6000...0...+6000 rpm Parameter set 2: n21/n22/n23 = -6000...0...+6000 rpm	
Time ranges of the speed ramps at $\Delta n = 3000 \text{ rpm}$		1. Ramp 2. Ramp Stop ramp Emergency ramp Motor potentiometer	t11/t21 up: 0...2000 s down: 0...2000 s t12/t22 up = down: 0...2000 s t13/t23 down: 0...20 s t14/t24 down: 0...20 s t3 up: 0.2...50 s down: 0.2...50 s
Auxiliary voltage output ¹⁾ X13:8/X10:8		VO24: $V_{OUT} = DC 24 \text{ V}$, maximum current carrying capacity $I_{max} = DC 400 \text{ mA}$	
External voltage supply ¹⁾ X10:9		VI24: $U_{IN} = DC 24 \text{ V} -15 \% / +20 \%$ according to EN 61131-2 With size 7, connect 24 V backup voltage via the DC power supply unit. No connection at the control unit.	
Binary inputs X13:1...X13:6 and X16:1/X16:2 Internal resistance Signal level Function	X13:1 X13:2...X13:6, X16:1/X16:2	Isolated (optocoupler), PLC-compatible (EN 61131), sampling interval 1 ms DIØØ...DIØ5 and DIØ6/DIØ7 $R_i \approx 3 \text{ k}\Omega$, $I_E \approx DC 10 \text{ mA}$	
		DC +13 V...+30 V = "1" = Contact closed DC -3 V...+5 V = "0" = Contact open	according to EN 61131
		DIØØ: With fixed assignment "/Controller inhibit" DIØ1...DIØ5, DIØ6/DIØ7: Selection option → Parameter menu P60_	
Binary outputs ¹⁾ X10:3/X10:7 and X16:3...X16:5 Signal level Function	X10:3 X10:7, X16:3...X16:5	PLC-compatible (EN 61131-2), response time 1 ms DBØØ/DOØ2 and DOØ3...DOØ5 "0" = DC 0 V "1" = DC +24 V Important: Do not apply external voltage! DBØØ: With fixed assignment "/Brake", $I_{max} = DC 150 \text{ mA}$, short-circuit proof, protected against external voltage to DC 30 V DOØ2, DOØ3...DOØ5: Selection option → Parameter menu P62_ $I_{max} = DC 50 \text{ mA}$, short-circuit proof, protected against external voltage to DC 30 V	
Relay output Function	X10:4...X10:6 X10:4 X10:5 X10:6	DOØ1: Load capacity of the relay contacts $U_{max} = DC 30 \text{ V}$, $I_{max} = DC 800 \text{ mA}$ DOØ1-C: Shared relay contact DOØ1-NO: Normally open contact DOØ1-NC: NC contact	
		Selection option → Parameter menu P62_	
System bus (SBus)	X12:1 X12:2 X12:3	DGND: Reference potential SC11: SBus high SC12: SBus low	CAN bus according to CAN specification 2.0, parts A and B, transmission technology according to ISO 11898, max. 64 stations, terminating resistor (120 Ω) can be activated using DIP switches
RS485 interface	X13:10 X13:11	ST11: RS485+ ST12: RS485-	EIA standard, 9.6 kbaud, max. 32 stations Max. cable length 200 m Dynamic terminating resistor with fixed installation
TF/TH/KTY input	X10:1	TF1: Response threshold at $R_{TF} \geq 2.9 \text{ k}\Omega \pm 10 \%$	

1) The unit provides a current of $I_{max} = DC 400 \text{ mA}$ for the DC+24 V outputs (VO24, binary outputs). If this value is insufficient, a DC 24 V voltage supply must be connected to X10:9 (VI24).

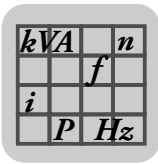

Technical Data of Basic Unit

MOVIDRIVE® MDX60/61B electronics data

MOVIDRIVE® MDX60/61B	General electronics data
Reference terminals X11:4 X12:1/X13:9/X16:6/X10:2/X10:10 X13:7	AGND: Reference potential for analog signals and terminals X11:1 and X11:5 (REF1/REF2) DGND: Reference potential for binary signals, system bus, RS485 interface and TF/TH DCOM: Reference potential for binary inputs X13:1...X13:6 and X16:1/X16:2 (DIØØ...DIØ5 and DIØ6/DIØ7)
Permitted cable cross section	One core per terminal: 0.20...2.5 mm ² (AWG 24...12) Two cores per terminal: 0.25...1 mm ² (AWG 22...17)
Safety contact X17:1 X17:2 X17:3 X17:4	DGND: Reference potential for X17:2 VO24: : V _{OUT} = DC 24 V, only to supply X17:4 of the same unit; cannot be used to supply other units. SOV24: Reference potential for DC+24 V "safe stop" input (safety contact) SVI24: DC+24 V "safe stop" input (safety contact)
Permitted cable cross section	One core per terminal: 0.08...1.5 mm ² (AWG28...16) Two cores per terminal: 0.25 ... 1.0 mm ² (AWG23...17)
Power consumption X17:4	Size 0: 3 W Size 1: 5 W Size 2, 2S: 6 W Size 3: 7.5 W Size 4: 8 W Size 5: 10 W Size 6: 6 W Size 7: 6 W
Input capacitance X17:4	Size 0: 27 µF Sizes 1...7: 270 µF
Time for restart Time to inhibit output stage	t _A = 200 ms t _S = 100 ms
Signal level	DC +19.2 V...+30 V = "1" = Contact closed DC -30 V...+5 V = "0" = Contact open

kVA	n
	f
i	
P	H_z

2.6 MOVIDRIVE® MDX60B dimension drawings

2.6.1 Size 0S

The following dimension drawing shows MDX60B size 0S, dimensions in mm (in)

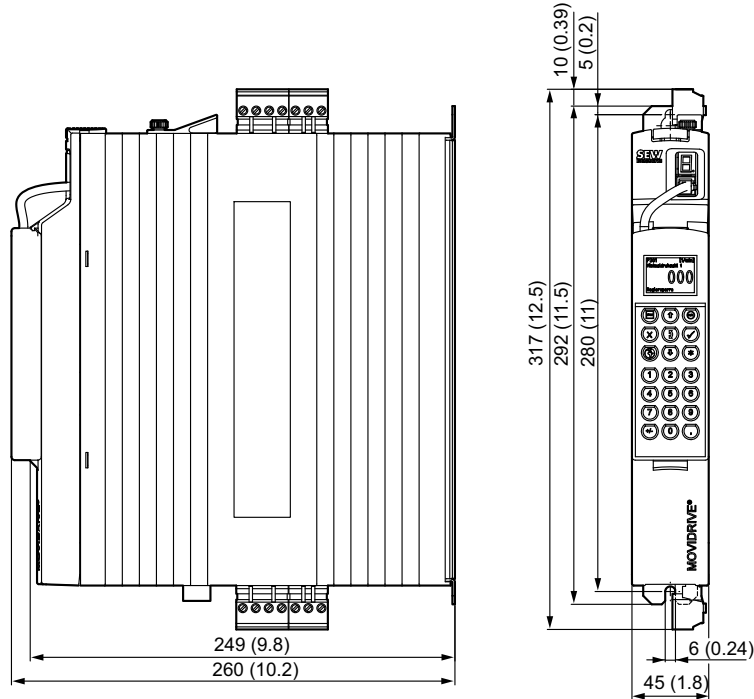

1940795915

2.6.2 Size 0S with mounted braking resistor

The following dimension drawing shows MDX60B size 0S with braking resistor, dimensions in mm (in)

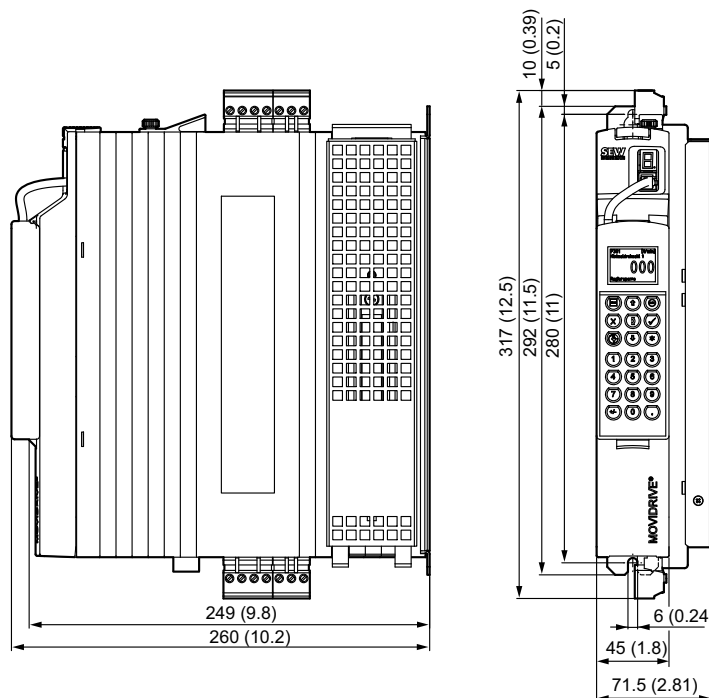

1940798987

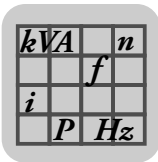

Technical Data of Basic Unit
MOVIDRIVE® MDX60B dimension drawings

2.6.3 Size 0M

The following dimension drawing shows MDX60B size 0M, dimensions in mm (in)

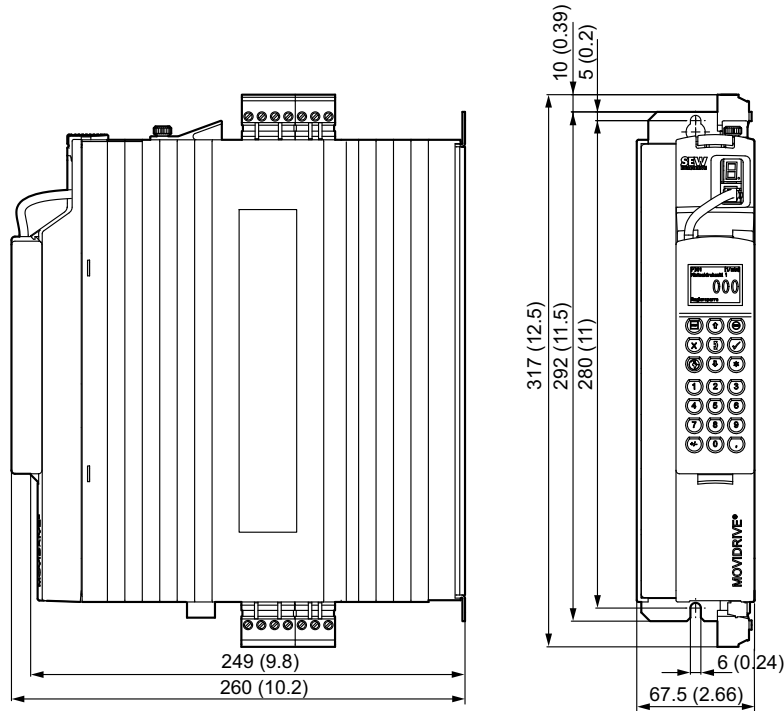

1940843915

2.6.4 Size 0M with mounted braking resistor

The following dimension drawing shows MDX60B size 0M with braking resistor, dimensions in mm (in)

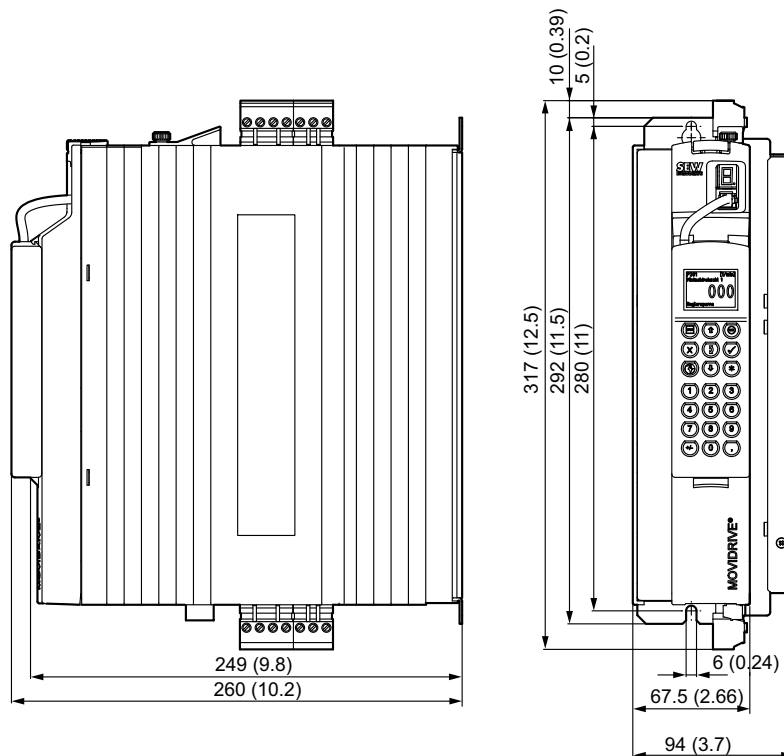

1940846987

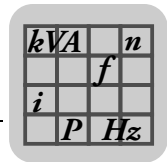

2.7 MOVIDRIVE® MDX61B dimension drawings

	INFORMATION
	For MOVIDRIVE® MDX61B size 0, installing a braking resistor does not affect the dimensions. Therefore, MOVIDRIVE® MDX61B size 0 dimensions are displayed without an installed braking resistor.

2.7.1 Size 0S

The following dimension drawing shows MDX61B size 0S, dimensions in mm (in)

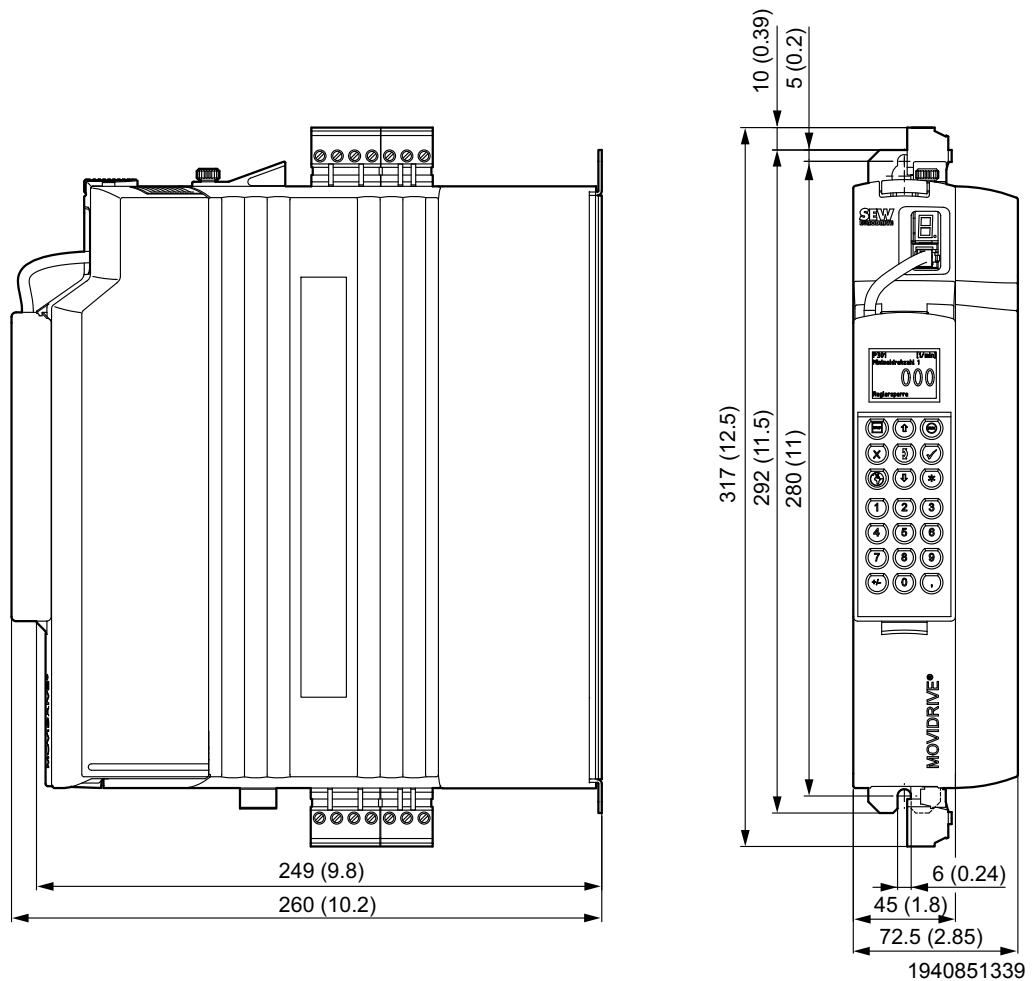

kVA	n
f	
i	
P	Hz

Technical Data of Basic Unit
MOVIDRIVE® MDX61B dimension drawings

2.7.2 Size 0M

The following dimension drawing shows MDX61B size 0M, dimensions in mm (in)

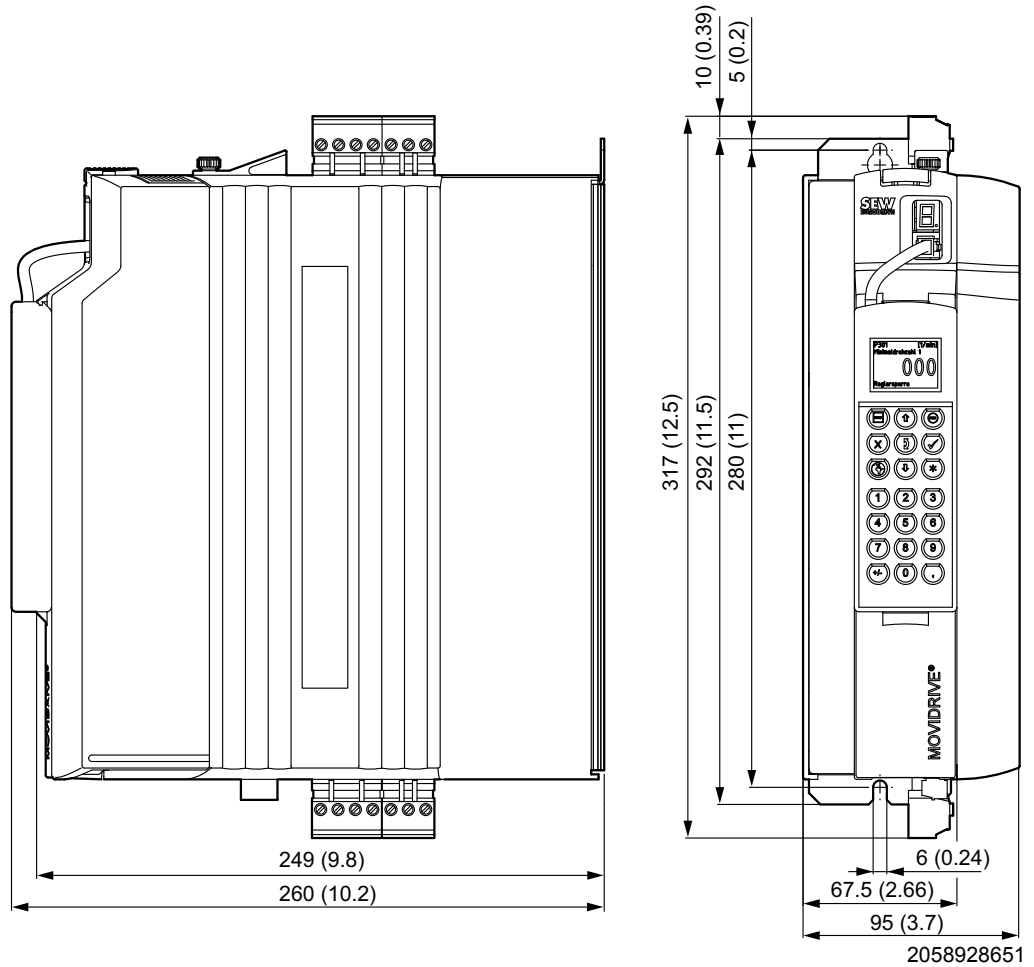

kVA	n
f	
i	
P	H_z

2.7.3 Size 1

The following dimension drawing shows MDX61B size 1, dimensions in mm (in)

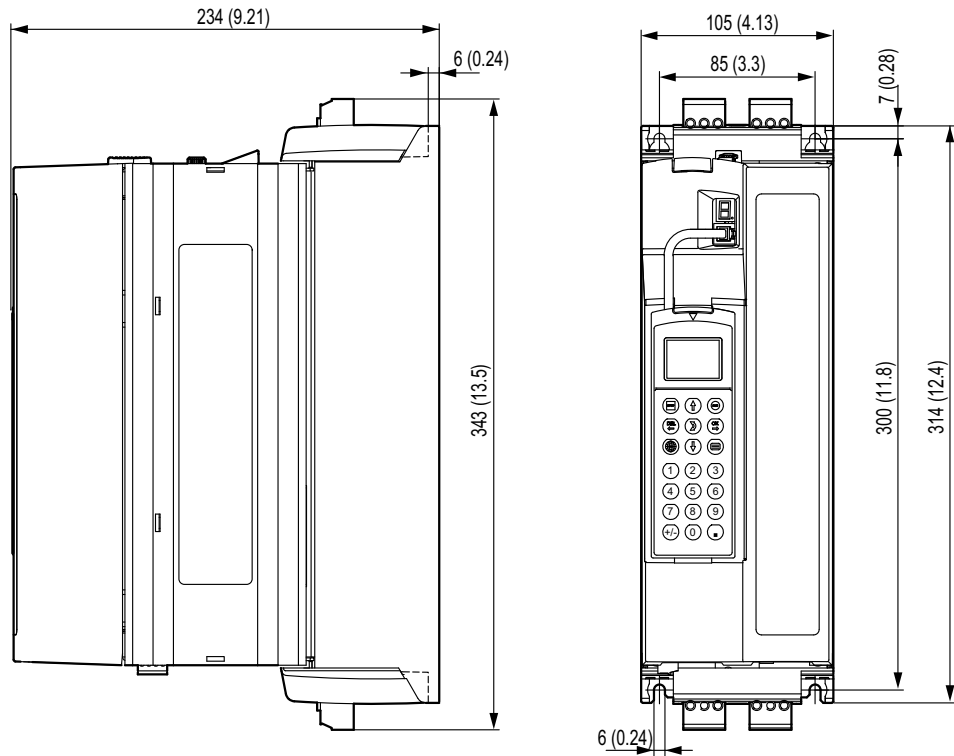

2058933131

kVA	n
f	
i	
P	Hz

2.7.4 Size 2S

The following dimension drawing shows MDX61B size 2S, dimensions in mm (in)

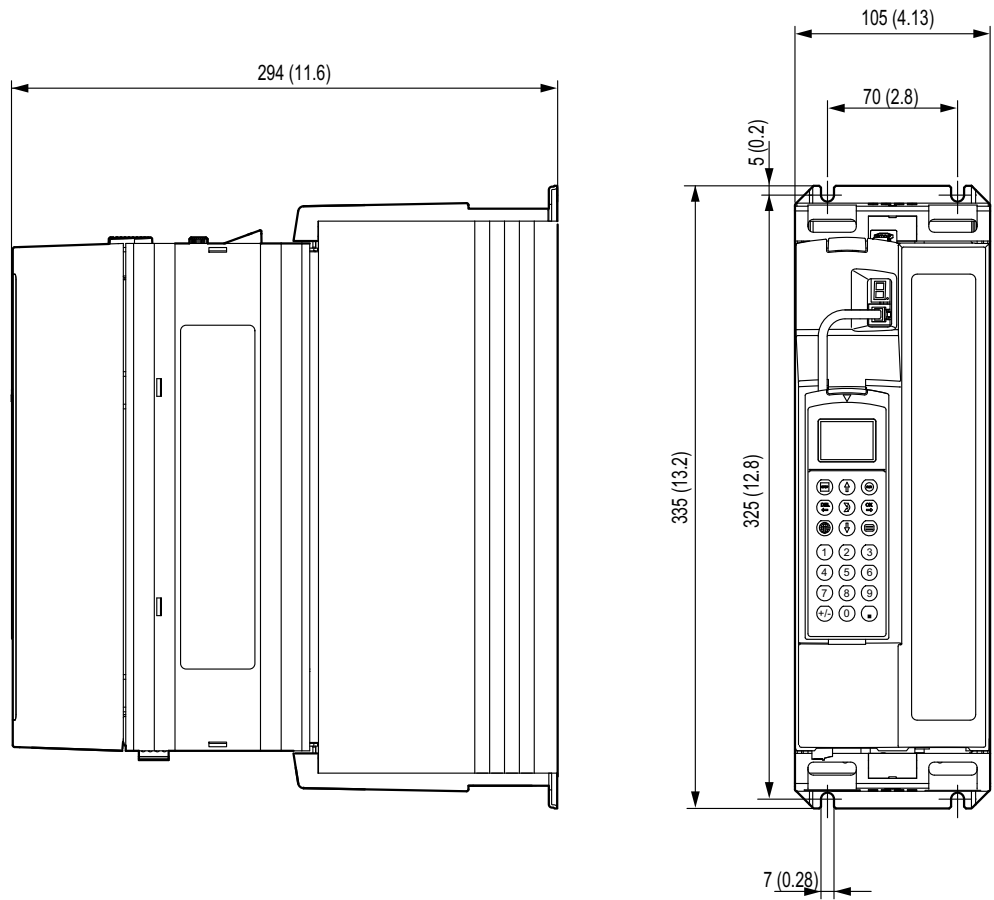

2058949003

<i>kVA</i>	<i>n</i>
<i>f</i>	
<i>i</i>	
<i>P</i>	<i>H_Z</i>

2.7.5 Size 2S

The following dimension drawing shows MDX61B size 2, dimensions in mm (in)

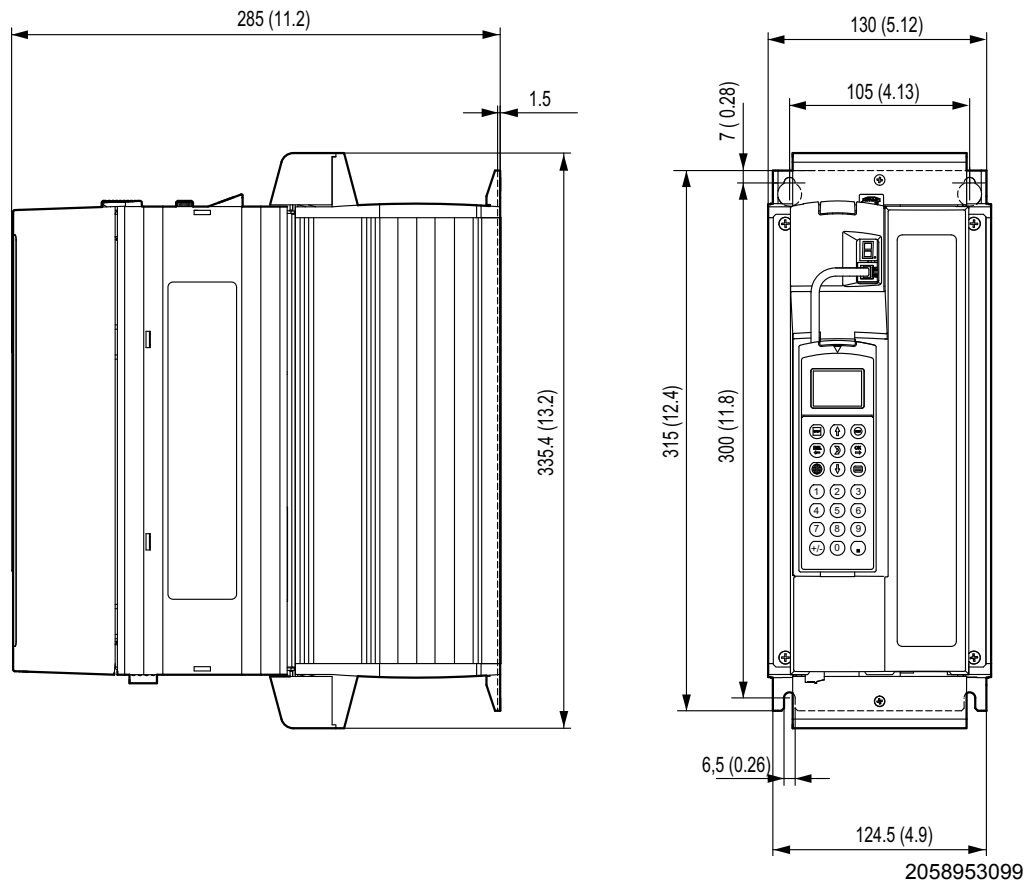

kVA	n
f	
i	
P	Hz

Technical Data of Basic Unit
MOVIDRIVE® MDX61B dimension drawings

2.7.6 Size 3

The following dimension drawing shows MDX61B size 3, dimensions in mm (in)

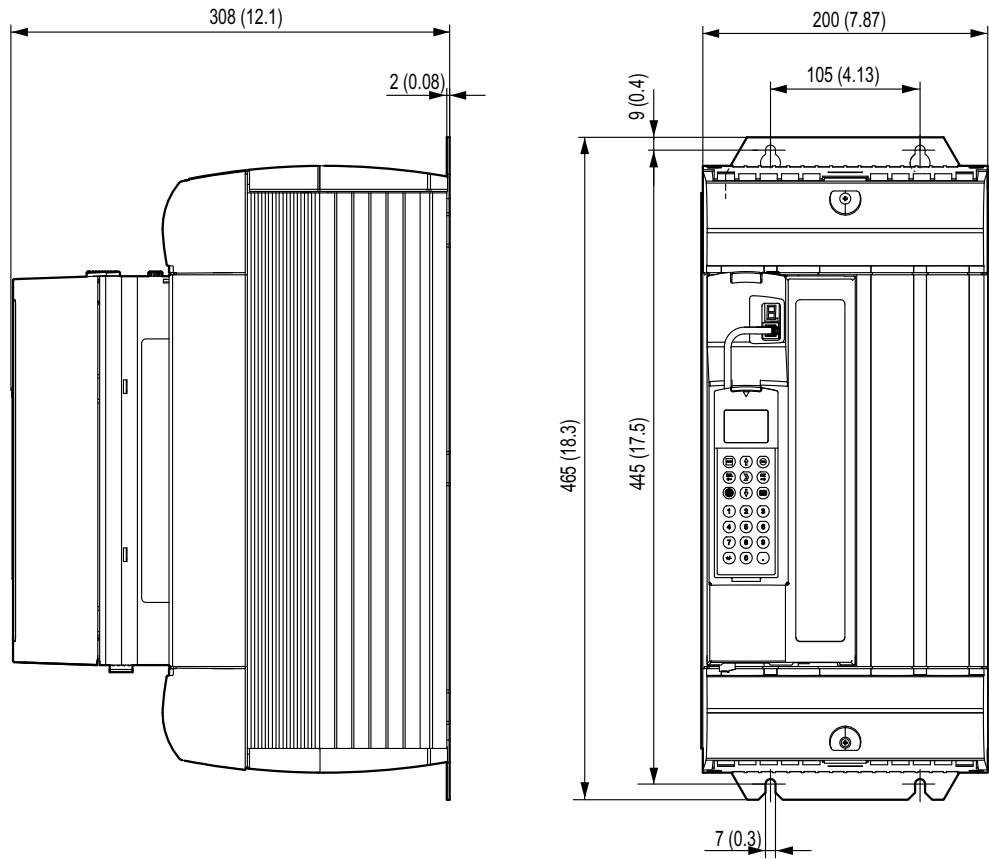

2058956683

kVA	n
i	f
P	H_z

2.7.7 Size 4

The following dimension drawing shows MDX61B size 4, dimensions in mm (in)

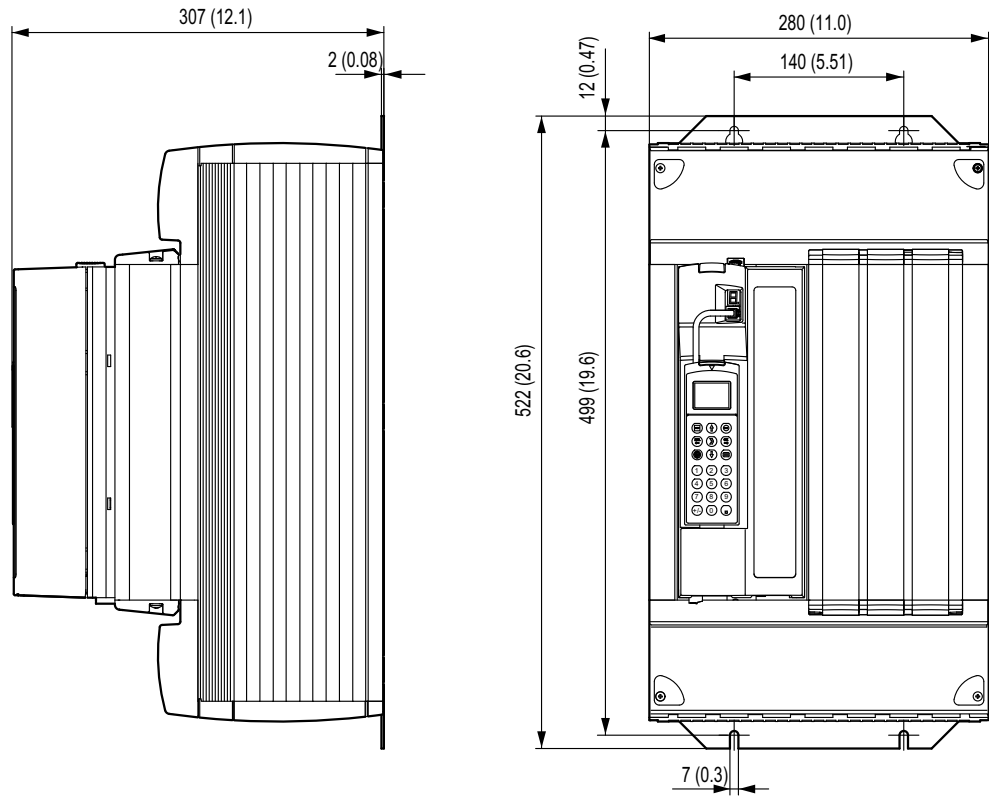

2058960267

kVA	n
i	f
P	H_z

2.7.8 Size 5

The following dimension drawing shows MDX61B size 5, dimensions in mm (in)

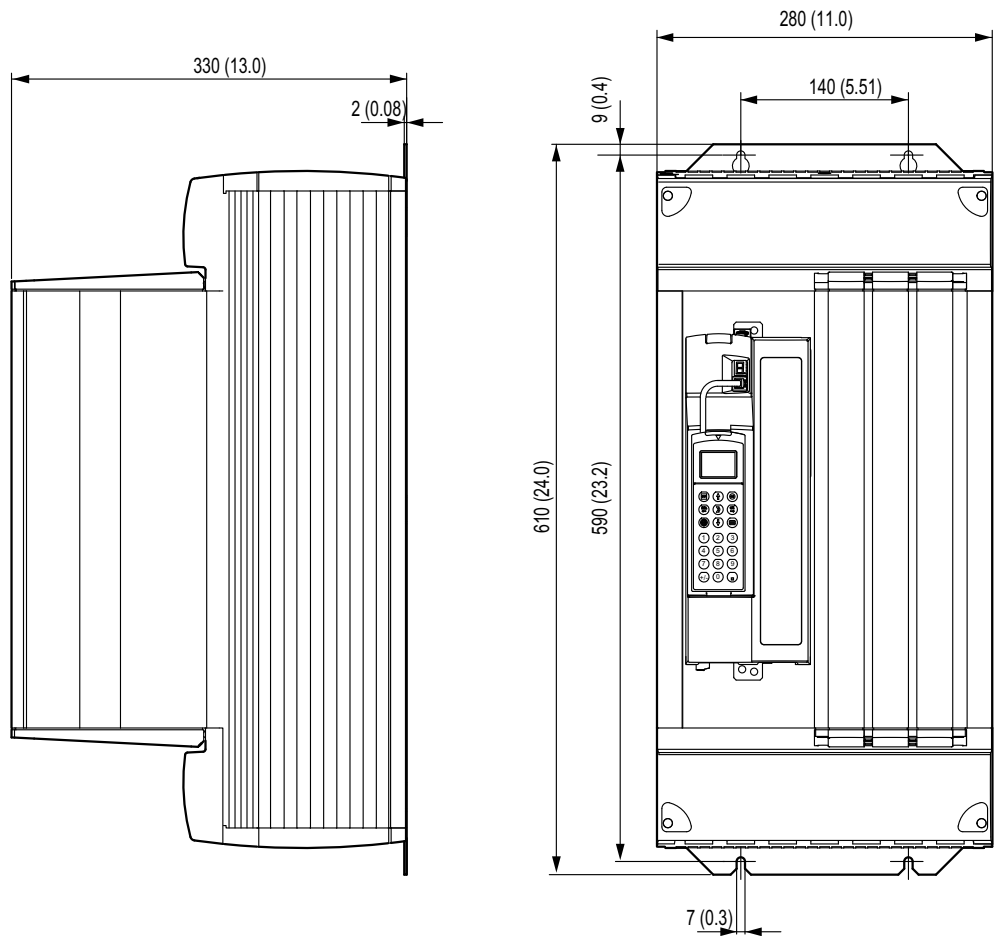

2058963851

kVA	n
f	
i	
P	H_z

2.7.9 Size 6

The following dimension drawing shows MDX61B size 6, dimensions in mm (in)

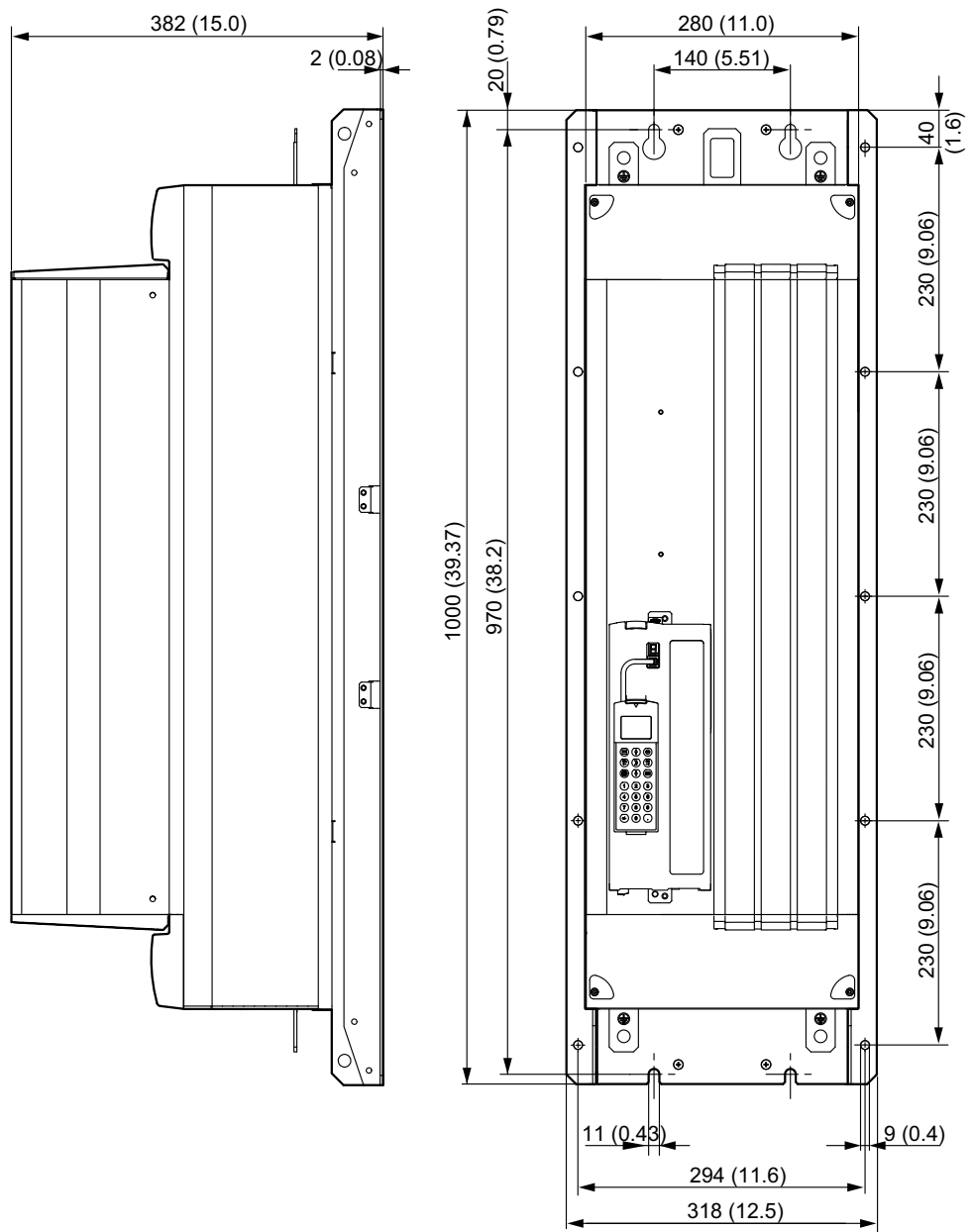

2058967435

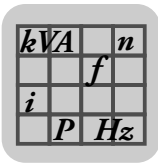

2.7.10 Size 7

The following dimension drawing shows MDX61B size 7, dimensions in mm (in)

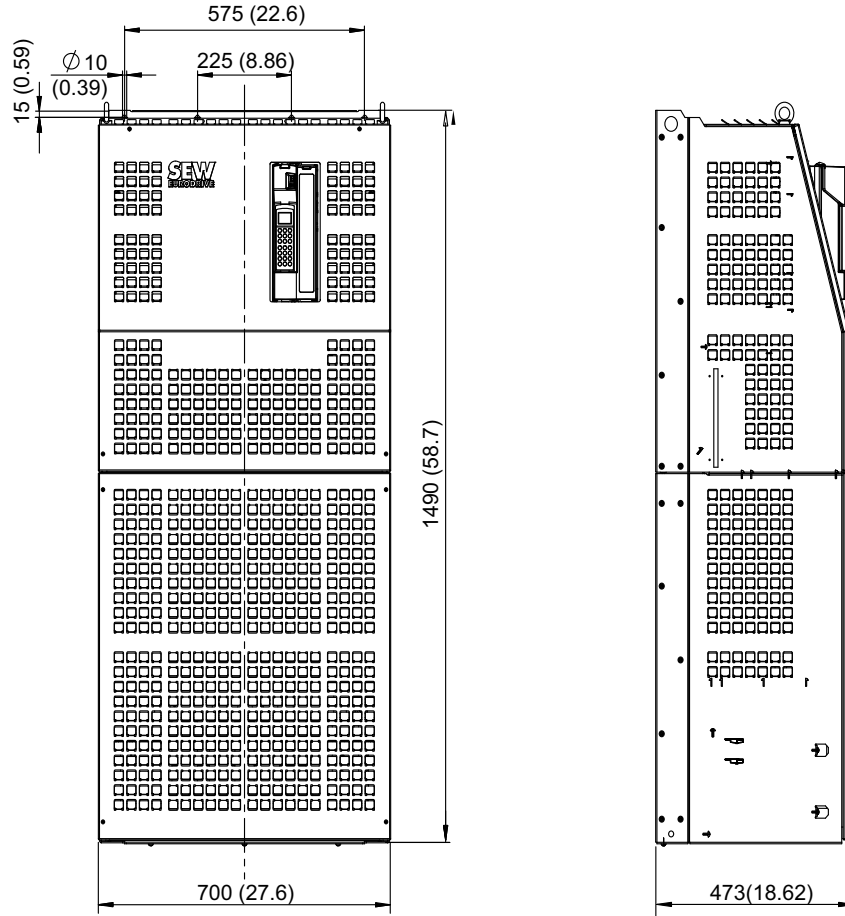

2058967435

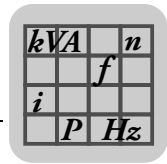

2.8 IPOS^{plus}®

2.8.1 Description

IPOS^{plus}® positioning and sequence control is integrated into every MOVIDRIVE® inverter as standard. IPOS^{plus}® can be used to execute control functions and positioning tasks either simultaneously or independently of one another.

IPOS^{plus}® sequence control makes it possible to run a user program, irrespective of any encoder feedback or the selected control mode (VFC, CFC, SERVO). In conjunction with encoder feedback, IPOS^{plus}® positioning control enables high-performance point-to-point positioning. The IPOS^{plus}® program is written using the MOVITOOLS® engineering software. Starting up the inverter, accessing parameters and editing variables are all possible either with the software or the DBG60B keypad (startup in VFC mode only).

2.8.2 Characteristics

- Program execution independent of encoder feedback and operating mode
- The user program is continued even if a unit malfunction occurs (troubleshooting is possible in the user program)
- Three user programs can be run in parallel and independently of one another (task 1, task 2 and task 3, each of them interrupt-capable)
- The user programs programmed in assembler can contain up to 3200 program lines
- User-friendly and comprehensive control options for the inverter
- Access to all available options
- Extensive options for communication via system bus (SBus), RS485, RS232 and fieldbus (direct communication with MOVIMOT® is possible)
- Processing of digital and analog input/output signals

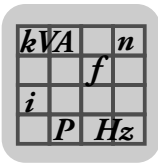

With encoder feedback only

- Positioning with selectable travel speed, positioning ramp and jerk limitation
- Precontrol for position, speed and torque control loops with minimized lag error
- Two touch probe inputs
- Ramp types: LINEAR, JERK LIMITED, SINE and SQUARE
- Status and monitoring functions: Lag error monitoring, position signal, software and hardware limit switches
- Nine types of reference travel
- Possibility of changing the target position, travel speed, positioning ramp and torque while movement is in progress
- "Endless positioning" is possible
- Override function
- Cam controller
- Synchronous operation and electronic cam

Max. program length of task 1, task 2 and task 3	Total of ca. 3200 program lines
Command processing time per program line	Task 1: 1 ... 10 commands/ms can be configured Task 2: 2 ... 11 commands/ms can be configured Task 3: At least 1 command/ms (typical is 40 commands/ms)
Variables	1024, of which 128 (0 ... 127) can be stored to non-volatile memory; range of values: $-2^{31} \dots + (2^{31}-1)$
Touch probe inputs	2 inputs, processing time < 100 μ s
Sampling cycle of digital and analog inputs	1 ms
Digital inputs/outputs	8 inputs / 5 outputs
Analog inputs/outputs	1 input (DC 0...10 V, DC \pm 10 V, DC 0...20 mA, DC 4...20 mA) 1 input (DC 0...10 V, DC \pm 10 V) 2 outputs (DC 0...20 mA, DC 4...20 mA, DC \pm 10 V)

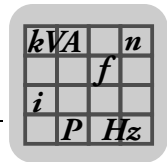

2.9 DBG60B keypad option

2.9.1 Description

The basic version of MOVIDRIVE® does not have a DBG60B keypad and can be upgraded to include the keypad as an option.

Keypad	Language variants	Part number
 <p>1454354443</p>	DBG60B-01 DE / EN / FR / IT / ES / PT / NL (German / English / French / Italian / Spanish / Portuguese / Dutch)	1820 403 1
	DBG60B-02 DE / EN / FR / FI / SV / DA / TR (German / English / French / Finnish / Swedish / Danish / Turkish)	1820 405 8
	DBG60B-03 DE / EN / FR / RU / PL / CS (German / English / French / Russian / Polish / Czech)	1820 406 6
	DBG60B-04 DE / EN / FR / ZH (German / English / French / Chinese)	1820 850 9
Door installation set¹⁾	Description (= scope of delivery)	Part number
DBM60B	<ul style="list-style-type: none"> Housing for DBG60B (IP65) DKG60B extension cable, length 5 m 	824 853 2
Extension cable	Description (= scope of delivery)	Part number
DKG60B	<ul style="list-style-type: none"> Length 5 m 4-core, shielded cable 	817 583 7

1) The DBG60B keypad is not included in the scope of delivery and must be ordered separately.

2.9.2 Functions

- Display process values and status
- Display status of binary inputs/outputs
- Error memory queries and error reset
- Option to display and set the operating parameters and service parameters
- Data backup and transfer of parameter sets to other MOVIDRIVE® units.
- User-friendly startup menu for VFC mode
- Manual control of MOVIDRIVE® B and MOVITRAC® B
- Manual operation of MOVIMOT® (→ Decentralized technology documentation)

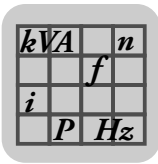

2.9.3 Features

- Illuminated text display, range of languages
- Keypad with 21 keys
- Selection between user menu, detailed parameter menu and startup menu in VFC mode (CFC and SERVO startup is not possible with the DBG60B)
- Can be plugged into MOVIDRIVE®
- Can be connected via extension cable DKG60B (5 m)
- Enclosure IP40 (EN 60529)

INFORMATION	
	<p>The DBG60B keypad option and the interface adapter are plugged into the same inverter slot (XT) and therefore cannot be used at the same time.</p>

2.9.4 Dimension drawing of DBG60B

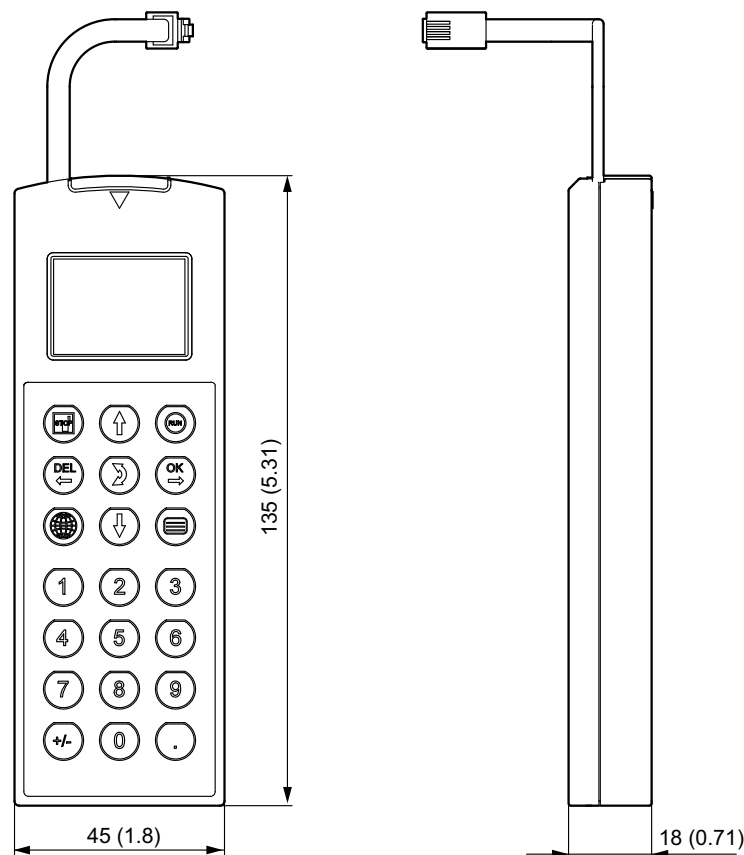

All dimensions in mm (in)

1454357771

kVA	n
f	
i	
P	H _Z

2.10 DBM60B/DKG60B housing option for DBG60B

2.10.1 Part numbers

- DBM60B 08248532
- DKG60B 08175837

2.10.2 Description

The DBM60B option can be used to mount the keypad close to the inverter (e.g. in the control cabinet door). The DBM60B option consists of housing in degree of protection IP65 and a 5 m (20 ft) long DKG60B extension cable.

2.10.3 Dimension drawing of DBM60B/DKG60B

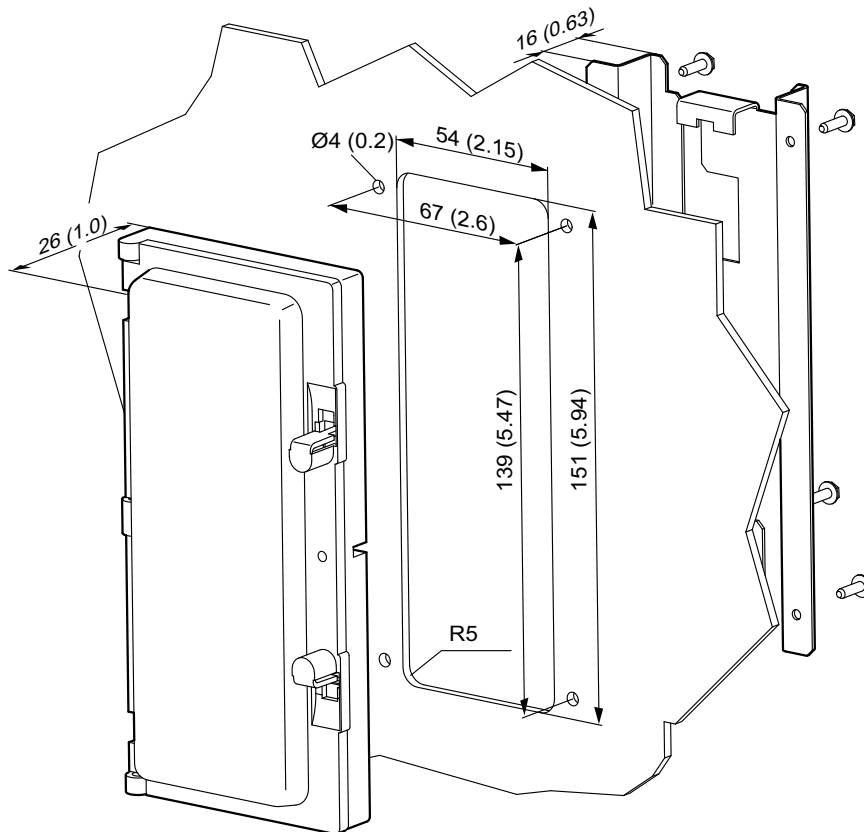

1454360843

All dimensions in mm (in)

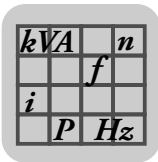

3 Technical Data of Regenerative Power Supply Unit

3.1 MOVIDRIVE® MDR60A regenerative power supply units

MOVIDRIVE® inverters operating in regenerative mode (4Q operation) can use the MOVIDRIVE® MDR60A regenerative power supply unit as an alternative to braking resistors. The prerequisite is a powerful supply system. For more detailed information, refer to the "MOVIDRIVE® MDR60A Regenerative Power Supply Unit" system manual. This manual can be ordered from SEW-EURODRIVE.

MOVIDRIVE® MDR60A supplies the DC link circuit of the connected MOVIDRIVE® inverter with electrical power from the supply system in motor operation and returns regenerative power to the supply system in regenerative operation.

3.1.1 UL approval



UL and cUL approval has been granted for MOVIDRIVE® MDR60A0150-503-01, MDR60A0370-503-00 and MDR60A0750-503-00 units. cUL is equivalent to CSA approval. The MOVIDRIVE® MDR60A1320-503-00 unit does not have UL or cUL approval.

3.1.2 Protection and monitoring functions

- Monitoring and protection against thermal overload.
- Detection of power failure within one supply system half-wave.
- Overvoltage protection.



1454307595

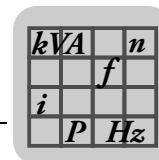

3.1.3 Characteristics of the regenerative power supply unit compared to an inverter with braking resistors

- Energy balance: Regenerative power is fed back into the supply system instead of being converted into waste heat.
- Less installation work with several inverters (network and braking resistor connections). However, a braking resistor is required to bring the drive to a controlled stop in case there is a disruption in the supply system.
- Reduction in use of control cabinet capacity and ventilator power if the braking resistor used to have to be installed in the control cabinet.

3.1.4 General technical data

MOVIDRIVE® MDR60A	0150-503-01 (size 3) 0370-503-00 (size 3) 0750-503-00 (size 4)	1320-503-00 (size 6)
Interference immunity	Meets EN 61800-3	Meets EN 61000-6-1 and EN 61000-6-2
Interference emission with EMC-compliant installation	Meets EN 61800-3: <ul style="list-style-type: none"> • with NF035-503 line filter (MDR60A0150-503-01) • with NF085-503 line filter (MDR60A0370-503-00) • with NF150-503 line filter (MDR60A0750-503-00) 	Meets EN 61000-6-4 with NF300503 line filter
Ambient temperature ϑ_U Ambient temperature derating	0 °C ... +40 °C I_N reduction: 3% I_N per K to max. 60 °C	0 °C ... +40 °C I_N reduction: 3% I_N per K to max. 55 °C
Climate class	EN 60721-3-3, class 3K3	
Storage temperature ¹⁾ ϑ_L	-25 °C ... +70 °C (EN 60721-3-3, class 3K3)	-25 °C ... +55 °C (EN 60721-3-3, class 3K3)
Cooling type (DIN 51751)	Forced cooling (temperature-controlled fan, response threshold 50 °C)	Forced cooling (temperature-controlled fan, response threshold 45 °C)
Degree of protection size 3 EN 60529 size 4 (NEMA1)	IP20 IP00 (power connections) IP10 (power connections) <ul style="list-style-type: none"> • With fitted plexiglass cover supplied as standard • With fitted shrink tubing (not included in scope of delivery) 	IP20
Operating mode	Continuous duty (EN 60149-1-1 and 1-3)	
Overvoltage category	III according to IEC 60664-1 (VDE 0110-1)	
Pollution class	2 according to IEC 60664-1 (VDE 0110-1)	
Installation altitude	At $h \leq 1000$ m without restrictions. The following restrictions apply to heights ≥ 1000 : <ul style="list-style-type: none"> • From 1000 m to max. 4000 m: <ul style="list-style-type: none"> – I_N reduction by 1% per 100 m • from 2000 m (6562 ft) to max. 4000 m (13120 ft): <ul style="list-style-type: none"> – The safe disconnection of power and electronics connections can no longer be assured above 2000 m. This requires external measures (IEC 60664-1/ EN 61800-5-1). – You have to connect an overvoltage protection device in order to reduce the overvoltages from category III to category II. 	$h \leq 1000$ m: No limitation From 1000 m to max. 4000 m: I_N reduction: 0.5% per 100 m

1) In case of long-term storage, connect the unit to the power supply for at least 5 minutes every two years, otherwise the unit's service life may be reduced.

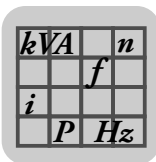

Technical Data of Regenerative Power Supply Unit MOVIDRIVE® MDR60A regenerative power supply units

3.1.5 Technical data of MOVIDRIVE® MDR60A regenerative power supply units

MOVIDRIVE® MDR60A size 3

MOVIDRIVE® MDR60A	0150-503-01 (size 3)	0370-503-00 (size 3)
Part number	1825 012 2	826 658 1
INPUT		
Rated line voltage (according to EN 50160)	V_{line}	3 × AC 380 V - 500 V
Line frequency	f_{line}	50 Hz - 60 Hz ± 5 %
Rated connected load	P_N	15 kW 37 kW
Rated line current I_{line} (at $V_{line} = 3 \times AC 400 V$)		AC 29 A AC 66 A
DC LINK		
Apparent output power (at $V_{line} = 3 \times AC 380...500 V$)	S_A	25 kVA 50 kVA
DC link	V_{DC}	DC 560 V - 780 V
Rated DC link current	I_{DCL}	DC 35 A DC 70 A
Max. DC link current	I_{DCL_max}	DC 53 A DC 105 A
GENERAL INFORMATION		
Power loss at P_N	P_{Vmax}	500 W 950 W
Cooling air consumption		100 m ³ /h 180 m ³ /h
Connection for power terminals (L1, L2, L3 for size 6) Permitted tightening torque Permitted cable cross section	X1, X2	M6 screw with washer 3.5 Nm (31 in-lb) 25 mm ² (AWG4)
Electronics terminals connection (X2 for size 6)	X3	Permitted cable cross-section: • One core per terminal: 0.20 – 2.5 mm ² (AWG 24 – 13) • Two cores per terminal: 0.20 – 1 mm ² (AWG 23 – 17)
Weight		16 kg (35 lb) 16 kg (35 lb)
Dimensions W × H × D		200 mm × 465 mm × 221 mm (7.87 in × 18.3 in × 8.7 in)
Line choke (always required)		ND045-013, $L_N = 0.1$ mH Part number 826 013 3
Line filter (optional)		ND085-013 $L_N = 0.1$ mH Part number 826 014 1
Line filter (optional)		NF035-503, Part number 827 128 3
Line filter (optional)		NF085-503, Part number 827 415 0
For MOVIDRIVE® MDX60B/61B...-5_3		0005 ... 0150 0005 ... 0370

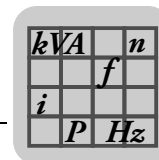

MOVIDRIVE® MDR60A size 4 and size 6

MOVIDRIVE® MDR60A	0750-503-00 (size 4)	1320-503-00 ¹⁾ (size 6)
Part number	826 556 9	827 952 7
INPUT		
Nominal line voltage (according to EN 50160)	V_{line}	3 × AC 380 V - 500 V
Line frequency	f_{line}	50 Hz - 60 Hz ±5 % 40 Hz - 60 Hz ±10 %
Rated connected load	P_N	75 kW 160 kW
Rated line current (at $V_{line} = 3 \times AC 400 V$)	I_{line}	AC 117 A AC 260 V
DC LINK		
Apparent output power (at $V_{line} = 3 \times AC 380...500 V$)	S_A	90 kVA 175 kVA
DC link	V_{DC}	DC 560 V - 780 V
Rated DC link current	I_{DCL}	DC 141 A DC 324 A
Max. DC link current	I_{DCL_max}	DC 212 A Motive: • DC 486 A Regenerative: • DC 410 A
GENERAL INFORMATION		
Power loss at P_N	P_{Vmax}	1700 W 2400 W
Cooling air consumption		360 m ³ /h 880 m ³ /h
Connection for power terminals (L1, L2, L3 for size 6)	X1, X2	M10 terminal studs M10 terminal studs
Permitted tightening torque		14 Nm (120 in-lb) 30 Nm (270 in-lb) ²⁾
Permitted cable cross section		70 mm ² (AWG2/0) 185 mm ² (DC link connection) / 32 Nm (280 in-lb) ¹⁾
Electronics terminals connection (X2 for size 6)	X3	Permitted cable cross-section: • One core per terminal: 0.20 – 2.5 mm ² (AWG 24 – 13) • Two cores per terminal: 0.20 – 1 mm ² (AWG 23 – 17) Permitted cable cross-section: • 0.75 – 2.5 mm ² (AWG18 – 14) Terminals A1 / A2: • 0.75 – 4 mm ² (AWG18 – 12)
Mass		24 kg (53 lb) 100 kg (200 lb)
Dimensions W × H × D		280 mm × 522 mm × 205 mm (11 in × 20.6 in × 8.07 in) 378 mm × 942 mm × 389.5 mm (14.9 in × 37.1 in × 15.3 in)
Line choke (always required)		ND200-0033 $L_N = 0.03$ mH Part number 826 579 8 Already installed
Line filter (optional)		NF150-503, Part number 827 417 7 NF300-503, Part number 827 419 3
For MOVIDRIVE® MDX60B/61B...-5_3		0005 ... 0750 0005 ... 1600
Recommended line fuse		- 500 A

- 1) The listed technical data applies to units with series no. DCV200xxx. For units of the previous series with no. DCV185xxx, refer to the provided documentation and the data on the nameplate.
- 2) Important: Do not apply tightening torque directly at terminals L1, L2, L3 and ±UG; use a second wrench.

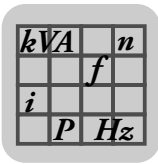

3.1.6 Dimension drawings of MDR60A

Provide at least 100 mm clearance above and below the unit. There is no need for clearance at the sides. You can line up the units directly next to one another. With sizes 4 and 6, do not install any components that are sensitive to high temperatures within 300 mm (11.8 in) of the top of the unit, for example contactors or fuses.

Size 3

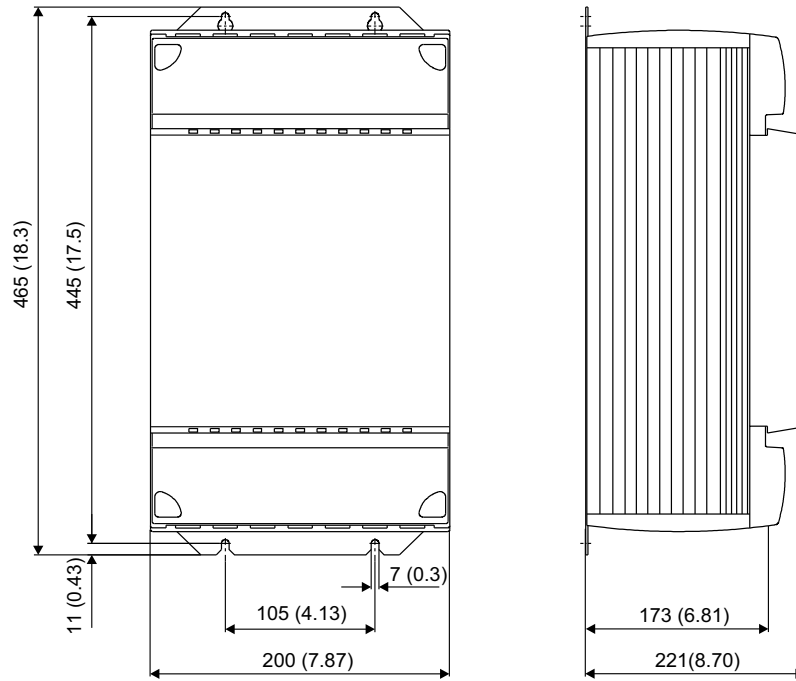

All dimensions in mm (in)

1454310923

Size 4

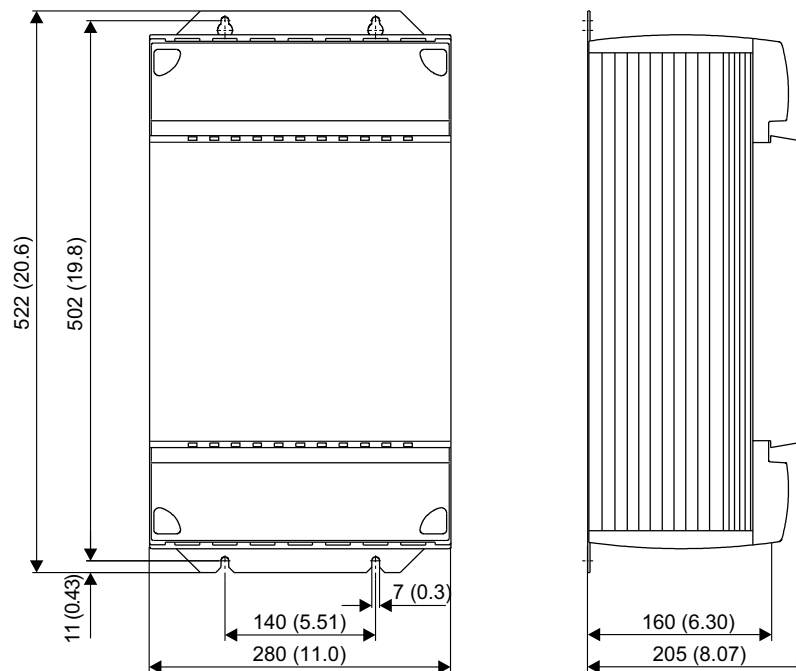

All dimensions in mm (in)

1454339595

kVA	n
f	
i	
P	H _Z

Size 6

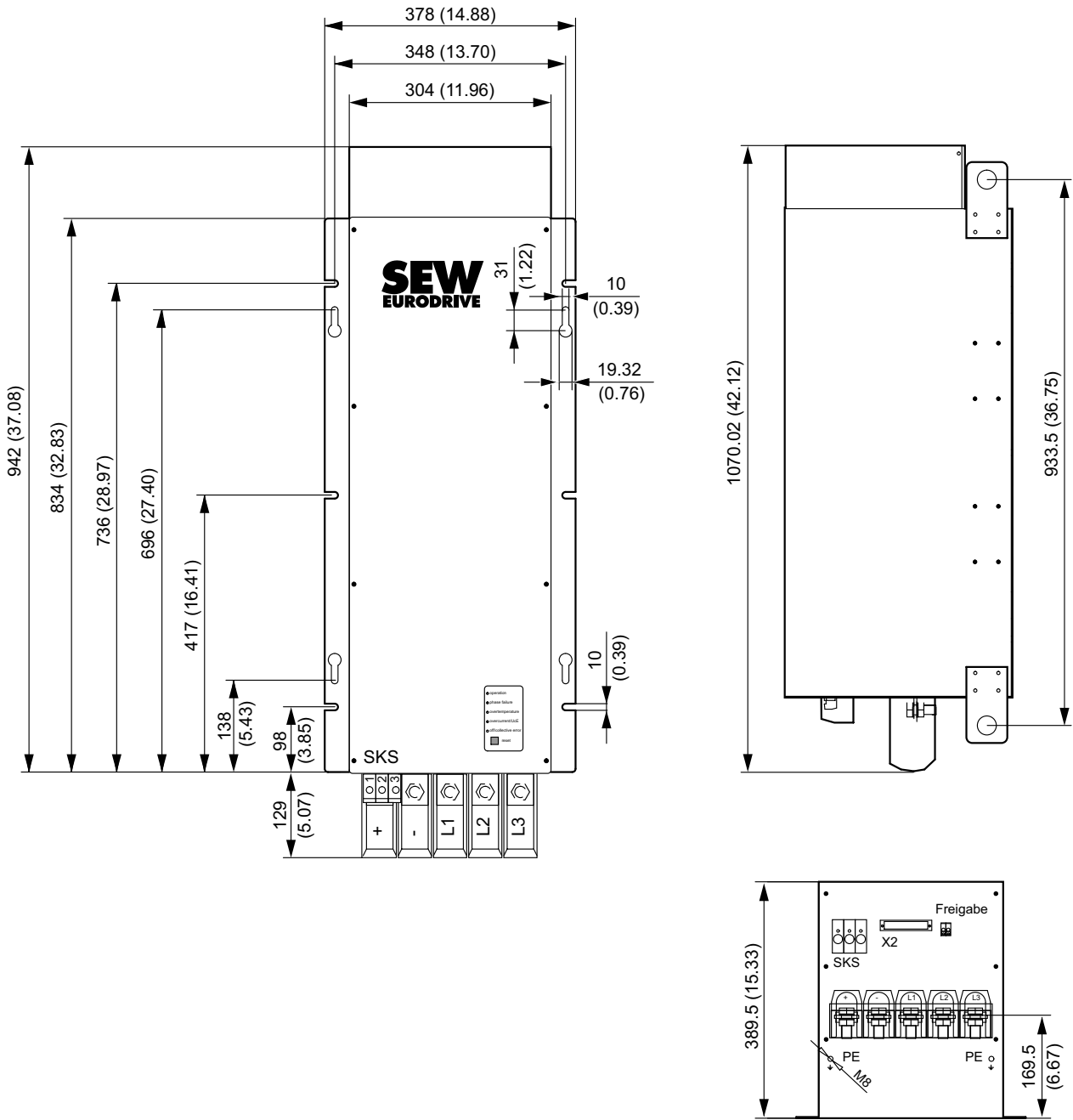

All dimensions in mm (in)

1454342923

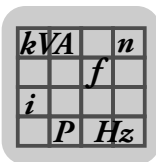

3.1.7 DC link connection

SEW-EURODRIVE recommends using the following cable sets for the DC link connection. These cable sets offer the appropriate dielectric strength and are also color-coded. Color coding is necessary because cross-polarity and ground faults could cause irreparable damage to the connected equipment.

The length of the cables restricts the DC link connection to the permitted length of 5 m. They can also be cut to length by the customer for connecting several units. The lugs for connection to the regenerative power supply unit and an inverter are supplied with the cable set. Use commercially available lugs for connecting additional inverters. The inverters must then be connected to the regenerative power supply unit in star configuration.

Cable set type	DCP12A	DCP13A	DCP15A	DCP16A
Part number	814 567 9	814 250 5	814 251 3	817 593 4
For connecting MOVIDRIVE®	0005 ... 0110	0150 ... 0370	0450 ... 0750	0900 ... 1320



INFORMATION

Refer to the "MOVIDRIVE® MDR60A Regenerative Power Supply Unit" system manual for information on the DC link connection. This system manual can be ordered from SEW-EURODRIVE.

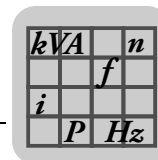

4 Technical Data of Options

4.1 DEH11B Hiperface® encoder card option

4.1.1 Part number

824 310 7

4.1.2 Description

The option capable MOVIDRIVE® MDX61B units can be equipped with the DEH11B Hiperface® encoder card. The encoder card offers one input for the motor encoder and one input for an external encoder, also referred to as distance encoder. The input for the external encoder can also be used as an output for incremental encoder simulation.

4.1.3 Electronics data

Option DEH11B		
 <p>2058970635</p>	Output for incremental encoder simulation or External encoder input X14:	Output for incremental encoder simulation: <ul style="list-style-type: none"> • Signal level to RS422 • The number of pulses is the same as on X15 motor encoder input
	Motor encoder input X15:	External encoder input (max. 200 kHz): Permitted encoder types: <ul style="list-style-type: none"> • Hiperface® encoder • Sin/cos encoder $V_{SS} = AC\ 1V$ • TTL encoder with negated tracks • Encoder with signal level to RS422 Encoder power supply <ul style="list-style-type: none"> • DC+12 V (tolerance range DC 10.5 - 13 V) • $I_{max} = DC\ 650\ mA^{1)}$
		Permitted encoder types: <ul style="list-style-type: none"> • Hiperface® encoder • Sin/cos encoder $V_{SS} = AC\ 1V$ • TTL encoder with negated tracks • Encoder with signal level to RS422 • Permitted PPR count: 128/256/512/1024/2048 increments Encoder power supply <ul style="list-style-type: none"> • DC+12 V (tolerance range DC 10.5 - 13 V) • $I_{max} = DC\ 650\ mA$

1) Total current load of DC 12 V encoder supply $\leq DC\ 650\ mA$.

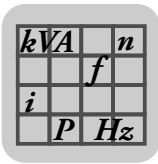

4.2 DER11B resolver card option

4.2.1 Part number

824 307 7

4.2.2 Description

Option-capable MOVIDRIVE® MDX61B units can be equipped with resolver card type DER11B. The resolver card offers one input for the resolver as motor encoder and one input for an external encoder, also referred to as distance encoder. The input for the external encoder can also be used as an output for incremental encoder simulation.

4.2.3 Electronics data

Option DER11B			
<p>DER 11B</p> <p>X14</p> <p>X15</p> <p>2058990603</p>	Output for incremental encoder simulation or External encoder input X14:	Output for incremental encoder simulation: Signal level to RS422 The number of pulses is 1024 pulses/revolution	External encoder input (max. 200 kHz): Permitted encoder types: <ul style="list-style-type: none"> • Hiperface® encoder • Sin/cos encoder $V_{SS} = AC 1 V$ • TTL encoder with negated tracks • Encoder with signal level to RS422 Encoder power supply <ul style="list-style-type: none"> • DC+12 V (tolerance range DC 10.5 - 13 V) • $I_{max} = DC 650 mA$
	Motor encoder input X15:	Resolver 2-pole, $V_{ref} = AC 7 V, 7 kHz$ $V_{in} / V_{ref} = 0.5 \pm 10 \%$	
	Maximum cable length:	100 m (328 ft)	

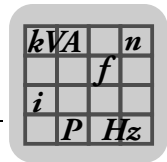

4.3 DEU21B multi-encoder card option

4.3.1 Part number

1822 169 6

4.3.2 Description

Option-capable MOVIDRIVE® MDX61B units can be equipped with a DEU21B multi-encoder card. The encoder card offers one input for the motor encoder and one input for an external encoder, also referred to as distance encoder.

Both encoder inputs can evaluate incremental and absolute encoders. The input for the external encoder can also be used as an output for incremental encoder simulation.

4.3.3 Electronics data

DEU21B option		
	<p>External encoder connection X14:</p> <p>Output for incremental encoder simulation:</p> <ul style="list-style-type: none"> • Signal level to RS422 • The number of pulses is the same as on X15 motor encoder input 	<p>Permitted encoder types:</p> <ul style="list-style-type: none"> • Hiperface® encoder • Sin/cos encoder $V_{SS} = AC 1 V$ • CANopen encoder • TTL encoder with negated tracks • HTL encoder • SSI encoder • SSI combination encoder • EnDat encoder • Encoder with signal level to RS422 • Permitted PPR count: 2-4096 increments <p>Encoder power supply</p> <ul style="list-style-type: none"> • DC 24 V encoder supply¹⁾ • DC 12 V encoder supply²⁾
	<p>Motor encoder connection X15:</p>	<p>Permitted encoder types:</p> <ul style="list-style-type: none"> • Hiperface® encoder • Sin/cos encoder $V_{SS} = AC 1 V$ • TTL encoder with negated tracks • HTL encoder • SSI encoder • SSI combination encoder • EnDat encoder • Encoder with signal level to RS422 • Permitted PPR count: 2-4096 increments <p>Encoder power supply</p> <ul style="list-style-type: none"> • DC 24 V voltage supply¹⁾ • DC 12 V voltage supply²⁾

1) If the overall unit load on the 24 V level exceeds 400 mA, you must connect an external DC 24 V supply to X10:9/X10:10. Observe the "Project planning" chapter in the "MOVIDRIVE® MDX60B/61B" system manual.

2) The maximum load on X14:15 and X15:15 is DC 650 mA in total.

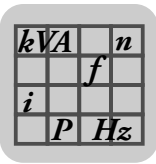

4.4 DEH21B/DIP11B absolute encoder card option

4.4.1 Part numbers

- DEH21B: 1820 818 5
- DIP11B: 824 969 5

4.4.2 Description

The DEH21B and DIP11B options extend the MOVIDRIVE® B system to include an SSI interface for absolute encoders. This option allows the following possibilities for IPOS^{plus}® positioning:

- No reference travel required when the system is started or after a power failure
- Positioning can take place either with the absolute encoder or the incremental encoder/resolver installed on the motor.
- No position switch needed on the travel distance, even without motor encoder feedback
- Free processing of the absolute position in the IPOS^{plus}® program
- In addition to the basic unit, 8 digital inputs and 8 digital outputs are available with the DIP11B option.
- The absolute encoder can be mounted either on the motor or along the track (e.g. high-bay warehouse)
- Simple encoder adjustment with user-guided startup
- Endless positioning in combination with activated modulo function

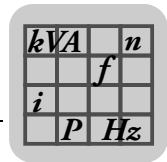

4.4.3 Electronics data for DEH21B

DEH21B option		
	Motor encoder connection X15:	Permitted encoder types: <ul style="list-style-type: none"> • Hiperface® encoder • Sin/cos encoder $V_{SS} = AC 1 V$ • TTL encoder with negated tracks • Encoder with signal level to RS422 • Permitted PPR count: 128/256/512/1024/2048 increments Encoder power supply , <ul style="list-style-type: none"> • DC+12 V (tolerance range DC 10.5 ... 13 V) • $I_{max} = DC 650 mA$
	Encoder connection X62:	SSI encoder input
	Voltage supply connection X60:1	24VIN: DC 24 V power supply for encoder connected to X62
	Reference terminal X60:2	Reference potential 24VIN

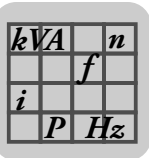

4.4.4 Electronics data for DIP11B

DIP11B option			
	Binary input connection	X60:1 ... 8	DI10 ... DI17 isolated via optocoupler, PLC compatible (EN 61131), scanning cycle 1 ms
	Internal resistance		$R_i \approx 3 \text{ k}\Omega$, $I_E \approx \text{DC } 10 \text{ mA}$
	Signal level (EN 61131)		DC+13 V ... +30 V = "1" / DC 3 V ... +5 V = "0"
	Function	X60:1 ... 8	DI10 ... DI17: Selection option → Parameter menu P61_
	Binary output connection	X61:1 ... 8	DO10 ... DO17, PLC-compatible (EN 61131), short-circuit proof and protected against external voltage to DC 30 V Response time 1 ms
	Signal level (EN 61131)		DC+24 V = "1" DC 0 V = "0" Important: Do not apply external voltage!
	Function	X61:1 ... 8	DO10 ... DO17: Selection option → Parameter menu P63_
Encoder connection X62:		SSI encoder input	
Reference terminals	X60:9 X60:10	DCOM: Reference potential for binary inputs (DI10 ... DI17) DGND: Reference potential for binary signals and 24VIN	
Permitted cable cross-section		<ul style="list-style-type: none"> without jumper X60:9-X60:10 (DCOM-DGND) isolated binary inputs With jumper X60:9-X60:10 (DCOM-DGND) non-isolated binary inputs 	
Voltage input	X61:9	24VIN: Supply voltage DC+24 V for binary outputs DO10 ... DO17 and encoder (mandatory)	
1454658571			

kVA	n
f	
i	
P	H _Z

4.5 Connector adapter for unit replacement MD_60A - MDX60B/61B

The following adapters are available for rapid replacement of a MOVIDRIVE® A unit with a MOVIDRIVE® B unit during system operation.

- DAT11B: Terminal adapter, part number 824 671 8

If the TF/TH option is connected to X10 when using MOVIDRIVE® MD_A, then X10 can be directly replugged. The jumper between X10:1 and X10:2 must be removed if a TF/TH option is connected to encoder input X15. Three plugs have to be rewired. You can avoid such rewiring work by using the DAT11B terminal adapter. Using this adapter will prevent incorrect connection and save time. The terminal adapter is required for terminals X11 (analog input), X12 (SBus) and X13 (binary inputs).

DAT11B



1454696587

- DAE15B: Encoder adapter X15, part number 817 629 9

If a motor with encoder on X15 is in operation on an MDV or MCV, the encoder is connected via a 9-pin plug connector to MOVIDRIVE® A. Since the DEH11B option for MOVIDRIVE® MDX61B comes equipped with a 15-pin socket, you will either have to convert the encoder cable or use the encoder adapter. The encoder adapter DAE15B for connecting sin/cos and TTL encoders can be inserted directly between the existing encoder cable with a 9-pin connector and the 15-pin socket on DEH11B. This step makes for fail-safe and fast connection of existing drives. HTL encoders have to be connected to MOVIDRIVE® B with the DWE11B/12B option (→ chapter "DWE11B/12B interface adapter option").

DAE15B



1454699659

Length of DAE15B: 200 mm ± 20 mm (7.87 in ± 0.79 in)

Cable cross section: 6 x 2 x 0.25 mm² (AWG 23)

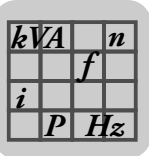

Technical Data of Options

Connector adapter for unit replacement MD_60A - MDX60B/61B

Terminal of the 15-pin sub D connector (MOVIDRIVE® MDX61B, DEH11B option, X15)	Core color in prefabricated cable	Terminal of 9-pin sub D socket (encoder end)
1	Yellow (YE)	1
2	Red (RD)	2
3	Pink (PK)	3
4	Violet (VT)	4
8	Brown (BN)	5
9	Green (GN)	6
10	Blue (BU)	7
11	Gray (GY)	8
15	White (WH)	9

- DAE14B: Encoder adapter X14, part number 817 630 2

If a distance encoder at X14 is operated on MOVIDRIVE® MDV, MDS, MCV or MCS, connection takes place via a 9-pin connector. Since the DEH11B and DER11B options for MOVIDRIVE® MDX61B come equipped with a 15-pin plug, you will either have to rework the encoder cable or use the DAE14B encoder adapter. The DAE14B encoder adapter can be plugged directly between the existing encoder cable with 9-pin socket and the 15-pin connector on the DEH11B//DER11B option. This step makes for fail-safe and fast connection of existing drives.

DAE14B



1454702731

Length of DAE14B: 200 mm ± 20 mm (7.87 in ± 0.79 in)

Cable cross section: 6 x 2 x 0.25 mm² (AWG 23)

Terminal of 15-pin sub D socket (MOVIDRIVE® MDX61B, DEH11B/DER11B option, X14)	Core color in prefabricated cable	Terminal of the 9-pin sub D connector (encoder end)
1	Yellow (YE)	1
2	Red (RD)	2
3	Pink (PK)	3
7	Violet (VT)	4
8	Brown (BN)	5
9	Green (GN)	6
10	Blue (BU)	7
11	Gray (GY)	8
15	White (WH)	9

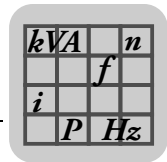

4.6 DWE11B/12B interface adapter option

4.6.1 Part number and description

- DWE11B, part number 188 187 6

The interface adapter DWE11B (HTL→TTL) in the form of an adapter cable is used **to connect single-ended HTL encoders to the DEH11B/DEH21B option**. Only the A, B and C tracks are connected. The interface adapter is suitable for all HTL encoders that were operated on MOVIDRIVE® A, MDV and MCV and can be connected without any rewiring effort.

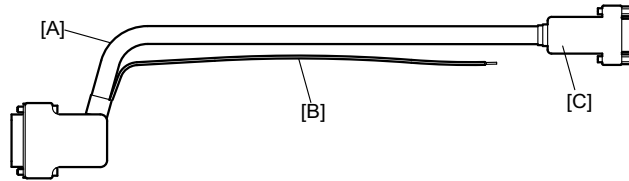

1805896331

[A] 5 x 2 x 0.25 mm² (AWG 23) / length 1000 mm (39.37 in) /

Max. line length inverter - encoder: 100 m (328 ft)

[B] DC 24 V connection for HTL encoder; 1 x 0.5 mm² (AWG 20)
/ length 250 mm (9.84 in)

Signal	Terminal of 9-pin sub D socket [C] (encoder end)
A	1
B	2
C	3
UB	9
GND	5

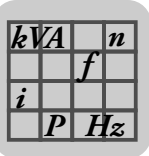

Technical Data of Options

DWE11B/12B interface adapter option

- DWE12B, part number 188 180 9

The interface adapter DWE12B (HTL→TTL) in the form of an adapter cable is used **to connect single-ended HTL encoders to the DEH11B/DEH21B option**. In addition to the A, B and C track, you will also have to connect the negated tracks (\bar{A} , \bar{B} , \bar{C}). SEW-EURODRIVE recommends using this interface adapter for any new system.

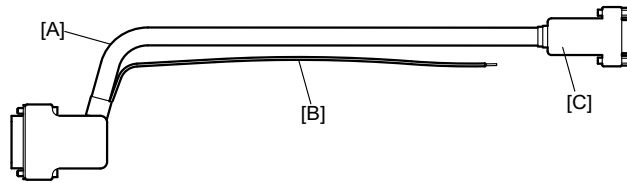

1805896331

- [A] 4 x 2 x 0.25 mm² (AWG 23 / length 1000 mm (39.37 in))
 Max. line length inverter - encoder: 200 m (656 ft)
- [B] DC 24 V connection for HTL encoder; 1 x 0.5 mm² (AWG 20)
 / length 250 mm (9.84 in)

Signal	Terminal of 9-pin sub D socket [C] (encoder end)
A	1
\bar{A}	6
B	2
\bar{B}	7
C	3
\bar{C}	8
UB	9
GND	5

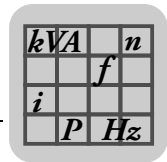

4.7 UWS11A interface adapter option

4.7.1 Part number

822 689 X

4.7.2 Description

The UWS11A option converts RS232 signals, for example from the PC, into RS485 signals. These RS485 signals can then be routed to the RS485 interface of the MOVIDRIVE[®] unit (ST11/ST12).

The UWS11A option requires a DC 24 V voltage supply ($I_{\max} = \text{DC } 50 \text{ mA}$).

4.7.3 RS232 interface

The connection between UWS11A and PC is made using a commercially available serial interface cable (shielded!).

4.7.4 RS485 interface

Max. 32 MOVIDRIVE[®] units can be networked for communication (max. line length 200 m (656 ft)) via the RS485 interface of the UWS11A. Do not connect external terminating resistors because dynamic terminating resistors are already installed!

Permitted cable cross-section: One core per terminal 0.20...2.5 mm² (AWG 24...12)

Two cores per terminal 0.20...1 mm² (AWG 24...17)

4.7.5 Dimension drawing of UWS11A

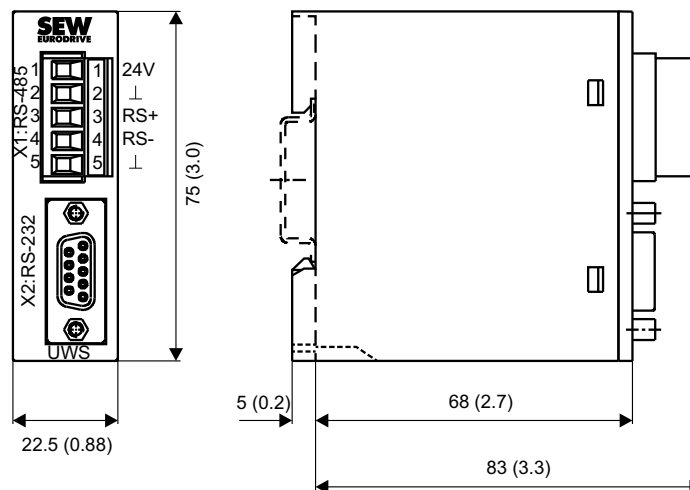

1454780939

All dimensions in mm (in)

The UWS11A option is mounted on a mounting rail (EN 50022-35 × 7.5) in the control cabinet.

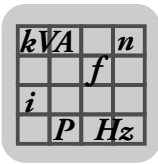

Technical Data of Options

UWS11A interface adapter option

4.7.6 Technical data

UWS11A	
Part number	822 689 X
Ambient temperature	0 ... 40 °C
Storage temperature	-25 °C ... +70 °C (according to EN 60721-3-3, class 3K3)
Degree of protection	IP20
Current consumption	Max. DC 50 mA
Mass	150 g (0.35 lb)
Dimensions	83 mm x 75 mm x 22.5 mm (3.3 in x 3.0 in x 0.866 in)

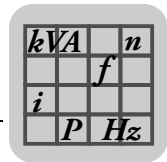

4.8 UWS21B interface adapter option

4.8.1 Part number

1820 456 2

4.8.2 Description

The UWS21B option converts RS232 signals, for example from the PC, into RS485 signals. These RS485 signals can then be routed to the XT slot of MOVIDRIVE® B.

4.8.3 RS232 interface

The connection of UWS21B with PC is made using a standard serial interface cable (shielded).

4.8.4 RS485 interface

UWS21B and MOVIDRIVE® B are connected using a serial interface cable with RJ10 connectors.

4.8.5 Scope of delivery

The scope of delivery for the UWS21B option includes:

- UWS21B
- Serial interface cable with 9-pin sub D socket and 9-pin sub D connector to connect the UWS21B option to the PC.
- Serial interface cable with two RJ10 connectors to connect UWS21B and MOVIDRIVE® B.
- CD-ROM with MOVITOOLS® MotionStudio engineering software

4.8.6 Dimension drawing of UWS21B

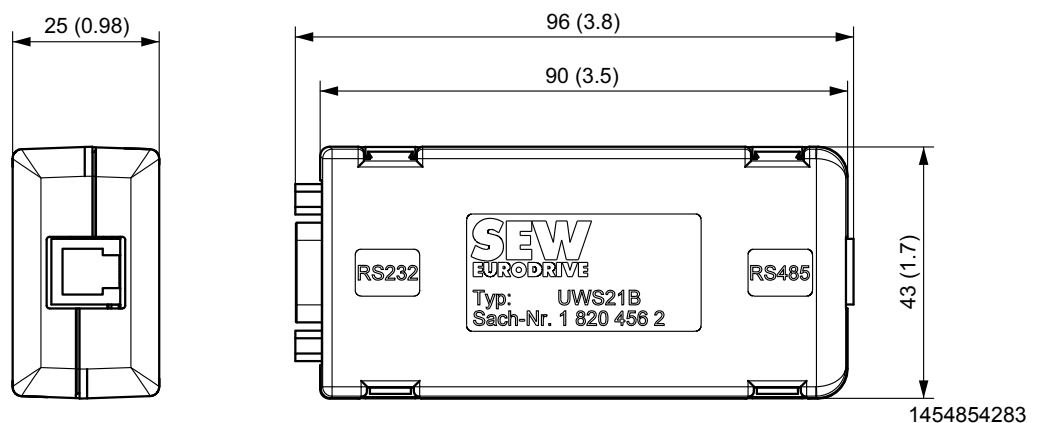

All dimensions in mm (in)

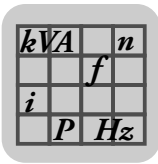

Technical Data of Options

UWS21B interface adapter option

4.8.7 Technical data

UWS21B	
Part number	1 820 456 2
Ambient temperature	0 ... 40 °C
Storage temperature	-25 °C ... +70 °C (according to EN 60721-3-3, class 3K3)
Degree of protection	IP20
Mass	300 g (0.7 lb)
Dimensions	96 mm x 43 mm x 25 mm (3.8 in x 1.7 in x 0.98 in)

kVA	n
	f
i	
P	Hz

4.9 USB11A interface adapter option

4.9.1 Part number

824 831 1

4.9.2 Description

Option USB11A can be used to connect a PC or laptop with a USB interface to the XT slot of MOVIDRIVE[®] B. The USB11A interface adapter supports USB 1.1 and USB 2.0.

4.9.3 USB11A - PC

USB11A is connected to the PC using a commercially available, shielded USB connection cable type USB A-B.

4.9.4 MOVIDRIVE[®] - USB11A

MOVIDRIVE[®] B and USB11A are connected using a serial interface cable with RJ10 connectors.

4.9.5 Scope of delivery

The scope of delivery for the USB11A option includes:

- USB11A interface adapter
- USB connection cable to connect USB11A - PC
- Serial interface cable with 2 RJ10 connectors to connect USB11A and MOVIDRIVE[®] B
- CD-ROM with drivers and MOVITOOLS[®] MotionStudio engineering software

4.9.6 Dimension drawing

All dimensions in mm (in)

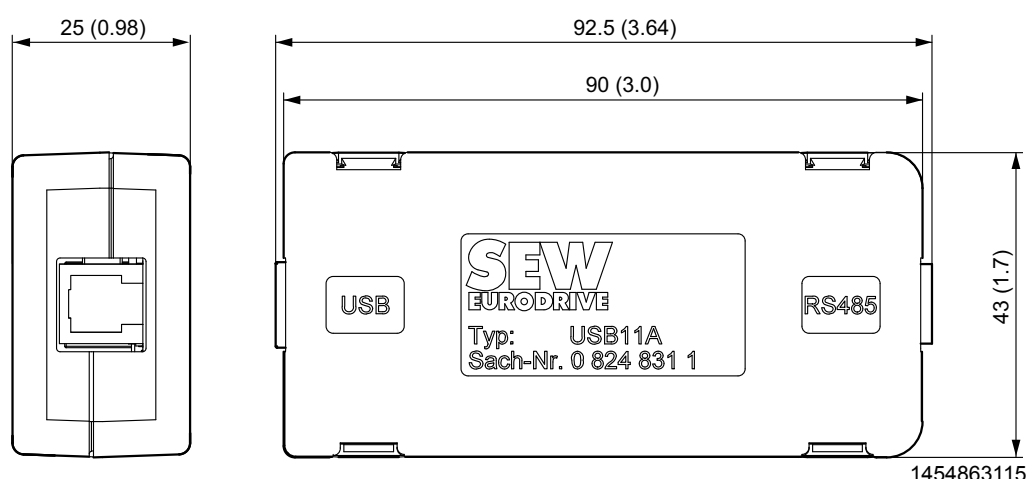

All dimensions in mm (in)

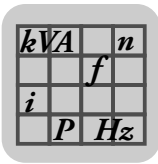

Technical Data of Options

USB11A interface adapter option

4.9.7 Technical data

USB11A	
Part number	824 831 1
Ambient temperature	0 ... 40 °C
Storage temperature	-25 °C ... +70 °C (according to EN 60721-3-3, class 3K3)
Degree of protection	IP20
Mass	300 g (0.7 lb)
Dimensions	92.5 mm x 43 mm x 25 mm (3.64 in x 1.7 in x 0.98 in)

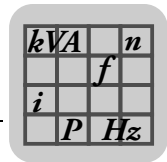

4.10 DWI11A DC 5 V encoders supply option

4.10.1 Part number

822 759 4

4.10.2 Description

If you are using an incremental encoder with a DC 5 V encoder power supply, install the DC 5 V encoder power supply option type DWI11A between the inverter and the incremental encoder. This option provides a regulated DC 5 V power supply for the encoder. For this purpose, the DC 12 V power supply for the encoder inputs is converted to DC 5 V by means of a voltage controller. A sensor line is used to measure the supply voltage at the encoder and compensate the voltage drop along the encoder cable.

Incremental encoders with DC 5 V encoder power supply are not allowed to be connected directly to the encoder inputs X14: and X15: . This would cause irreparable damage to the encoder.

	INFORMATION
	Note that if a short circuit occurs in the sensor cable, the connected encoder may be exposed to a voltage higher than permitted.

4.10.3 Recommendation

Use prefabricated cables from SEW for the encoder connection.

4.10.4 Dimension drawing

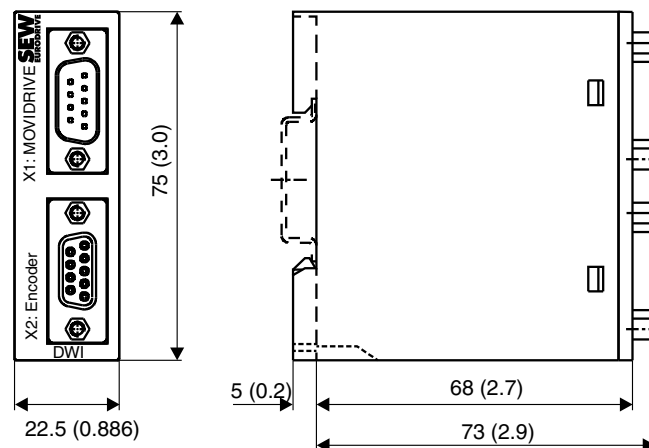

1454869899

All dimensions in mm (in)

The DWI11A option is mounted on a support rail (EN 50022-35 × 7.5) in the control cabinet.

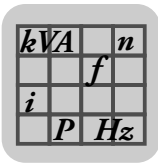

Technical Data of Options

DWI11A DC 5 V encoders supply option

4.10.5 Technical data

DWI11A DC 5 V encoder supply option	
Part number	822 759 4
Voltage input	DC 10...30 V, I_{\max} = DC 120 mA
Encoder power supply	DC +5 V (up to $V_{\max} \approx +10$ V), I_{\max} = DC 300 mA
Max. line length that can be connected	100 m (328 ft) total Use a shielded twisted-pair cable (A and \bar{A} , B and \bar{B} , C and \bar{C}) for connecting the encoder to the DWI11A and the DWI11A to MOVIDRIVE®.

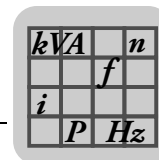

4.11 DIO11B input/output card option

4.11.1 Part number

824 308 5

4.11.2 Description

The number of inputs/outputs of the basic MOVIDRIVE® B unit can be expanded with the DIO11B option. The DIO11B option is plugged into the fieldbus slot. If the fieldbus slot is not available, you can plug the DIO11B option into the expansion slot. The programmable signal types of the additional binary inputs/outputs are the same as the basic unit (→ parameter group P6___, Terminal assignment).

4.11.3 Electronics data

Option DIO11B		
<p>1454878091</p>	Setpoint input n2 X20:1/X20:2 AI21/AI22 operating mode Resolution Internal resistance	AI21/AI22: Voltage input Differential input or input with AGND reference potential n2 = DC 0...+10 V or DC -10 V...0...+10 V 12 bit, sampling time 1 ms $R_i > 40 \text{ k}\Omega$
	Analog outputs X21:1/X21:4 X21:2/X21:5 Response time Resolution	AOV1/AOV2: Voltage outputs DC -10 V...0...+10 V, $I_{\text{max}} = \text{DC } 10 \text{ mA}$, short-circuit proof and protected against external voltage to DC 30 V, selection option → parameter menu P64_ AOC1/AOC2: Current outputs DC 0(4)...20 mA, max. output voltage DC 15 V, short-circuit proof and protected against external voltages up to DC 30 V, selection option → parameter menu P64_ 5 ms 12 bit
	Binary inputs X22:1...X22:8 Internal resistance	Isolated (optocoupler), PLC compatible (EN 61131) DI1Ø...DI17 $R_i \approx 3 \text{ k}\Omega$, $I_E \approx \text{DC } 10 \text{ mA}$ Sampling time 1 ms
	Signal level	DC+13 V...+30 V = "1" = Contact closed DC -3 V...+5 V = "0" = Contact open Complies with EN 61131
	Function X22:1...X22:8	DI10...DI17: Selection option → Parameter menu P61_
	Binary outputs X23:1...X23:8 Signal level Function X23:1...X23:8	DO1Ø...DO17: PLC-compatible (EN 61131-2), response time 1 ms "0" = DC 0 V "1" = DC+24 V DO10...DO17: Selection option → Parameter menu P63_ $I_{\text{max}} = \text{DC } 50 \text{ mA}$, short-circuit proof and protected against external voltage to DC 30 V
	Reference terminals X20:3/X21:3/ X21:6 X22:9 X22:10	AGND: Reference potential for analog signals (AI21/AI22/AO_1/AO_2) DCOM: Reference potential for binary inputs X22:1...X22:8 (DI1Ø...DI17) DGND: Reference potential for binary signals, reference potential for DC 24 V power supply
	Voltage input X23:9	24VIN: Supply voltage DC +24 V for binary outputs DO1Ø...DO17
	Permitted cable cross-section	One core per terminal: 0.08...1.5 mm ² (AWG 28...16) Two cores per terminal: 0.25...1 mm ² (AWG 22...17)

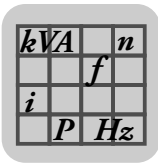

Technical Data of Options

DIO11B input/output card option

4.11.4 Functions

- 8 binary inputs
- 8 binary outputs
- 1 analog differential input (DC 0...10 V, DC -10 V...+10 V, DC 0...20 mA with corresponding load)
- 2 analog outputs (DC -10 V ... +10 V, DC 0...20 mA, DC 4...20 mA)

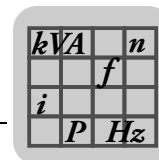

4.12 DFP21B PROFIBUS fieldbus interface option

4.12.1 Part number

824 240 2

4.12.2 Description

MOVIDRIVE® B can be equipped with a 12 Mbaud fieldbus interface for the PROFIBUS-DP serial bus system. The device master data (GSD) and type files for MOVIDRIVE® B are available from the SEW homepage (<http://www.sew-eurodrive.de>) under "Software" to help with project planning and facilitate startup.

PROFIBUS-DP (Decentralized Periphery) is primarily used at the sensor/actuator level where fast response times are required. The principal task of PROFIBUS-DP is rapid cyclic data exchange; e.g. setpoints or binary commands, between central automation units (PROFIBUS master) and decentralized peripheral units (e.g. drive inverters). The DFP21B option supports PROFIBUS-DP and DP-V1. Consequently, MOVIDRIVE® B can be controlled via PLC and PROFIBUS-DP / DP-V1.

4.12.3 Electronics data

DFP21B option		
	Protocol variant	PROFIBUS-DP and DPV1 to IEC 61158
	Baud rate	Automatic baud rate detection from 9.6 kbaud to 12 Mbaud
	Connection technology	9-pin sub D socket, pin assignment to IEC 61158
	Bus termination	Not integrated, implement using suitable PROFIBUS connector with terminating resistors that can be activated
	Station address	1 ... 125, adjustable via DIP switches
	GSD file name	DP: SEW_6003.GSD DP-V1: SEWA6003.GSD
	DP ID number	6003 _{hex} (24579 _{dec})
	Max. number of process data	10 process data

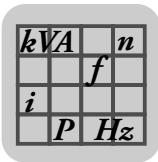

4.13 DFI11B INTERBUS fieldbus interface option

4.13.1 Part number

824 309 3

4.13.2 Description

MOVIDRIVE® B can be equipped with a fieldbus interface for the non-proprietary and standardized INTERBUS sensor/actuator bus system.

INTERBUS is defined in EN 50254 / DIN 19258 and, as far as its function is concerned, it consists of a process data channel and a parameter data channel. Intelligent actuators such as the MOVIDRIVE® B inverter can be controlled and configured in a user-friendly way.

4.13.3 Electronics data

DFI11B option		
	Supported baud rates	500 kBaud and 2 MBaud, can be selected via DIP switch
	Connection technology	Remote bus input: 9-pin D-sub connector Remote bus output: 9-pin D-sub socket RS485 transmission technology, 6-core shielded and twisted-pair cable
	DP identity numbers	E3 _{hex} = 227 _{dec} (1 PCP word) E0 _{hex} = 224 _{dec} (2 PCP words) E1 _{hex} = 225 _{dec} (4 PCP words) 38 _{hex} = 56 _{dec} (microprocessor not ready) 03 _{hex} = 3 _{dec} (no PCP word)
	Max. number of process data	6 process data

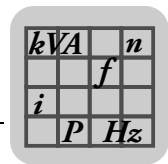

4.14 DFI21B INTERBUS optical fiber fieldbus interface option

4.14.1 Part number

824 311 5

4.14.2 Description

MOVIDRIVE® B can be equipped with a fieldbus interface for the non-proprietary and standardized sensor/actuator bus system INTERBUS / INTERBUS with optical fibers (INTERBUS optical fiber).

INTERBUS is defined in EN 50254 / DIN 19258 and, as far as its function is concerned, it consists of a process data channel and a parameter data channel. Intelligent actuators such as the MOVIDRIVE® B inverter can be controlled and configured in a user-friendly way.

4.14.3 Electronics data

DFI21B option		
<p>DFI 21B</p> <p>0 1</p> <p>20</p> <p>21</p> <p>22</p> <p>1 4</p> <p>2 0,5M</p> <p>U_L</p> <p>RC</p> <p>BA</p> <p>RD</p> <p>FO1</p> <p>FO2</p> <p>TR</p> <p>X31 / OUT ↔ X30 / IN</p> <p>X33 / OUT ↔ X32 / IN</p> <p>1455171339</p>	Supported baud rates	500 kBaud and 2 MBaud, can be selected via DIP switch
	Connection technology	F-SMA connector
	DP identity numbers	E3 _{hex} = 227 _{dec} (1 PCP word) E0 _{hex} = 224 _{dec} (2 PCP words) E1 _{hex} = 225 _{dec} (4 PCP words) 38 _{hex} = 56 _{dec} (microprocessor not ready) 03 _{hex} = 3 _{dec} (no PCP word)
	Max. number of process data	6 process data

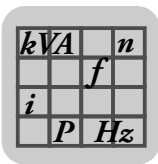

4.15 DFE32B PROFINET IO RT fieldbus interface option

4.15.1 Part number

1821 345 6

4.15.2 Description

The MOVIDRIVE[®] MDX61B inverter enables you to use the DFE32B option to connect to higher-level automation, project planning and visualization systems via Ethernet (PROFINET/IO protocol) thanks to its powerful, universal fieldbus interface. You can use option DFE32B to communicate directly with the inverters via Ethernet and operate the MOVITOOLS[®] software to change parameters and IPOS^{plus}[®] programs. An integrated Web server makes it possible for the user to access diagnostic values quickly and easily using a standard browser (e.g. Internet Explorer).

4.15.3 Electronics data

DFE32B option		
	Application protocols	<ul style="list-style-type: none"> • PROFINET IO (Ethernet frames with frame identification 8892_{hex}) to control and parameterize the inverter. • HTTP (Hypertext Transfer Protocol) for diagnostics using a Web browser. • SMLP (Simple MOVILINK Protocol), protocol used by MOVITOOLS[®] MotionStudio.
	Port numbers used	<ul style="list-style-type: none"> • 300 (SMLP) • 80 (HTTP)
	Ethernet services	<ul style="list-style-type: none"> • ARP • ICMP (ping)
	ISO / OSI layer 2	Ethernet II
	Baud rate	100 Mbaud in full duplex mode
	Connection technology	Two RJ45 plug connectors with integrated switch and auto-crossing
	Addressing	4 byte IP address or MAC-ID (00:0F:69:xx:xx:xx)
	Manufacturer ID (Vendor ID)	010A _{hex}
	Tools for startup	<ul style="list-style-type: none"> • MOVITOOLS[®] MotionStudio engineering software version 5.40 or higher. • DBG60B keypad
	Firmware status of MOVIDRIVE [®] MDX61B	Firmware version 824 854 0.17 or higher (→ display with P076)

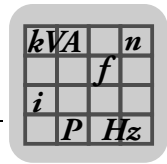

4.15.4 Functions

- PROFINET IO protocol
- Two RJ45 plug connectors for star or line type cabling
- Up to 10 process data and PROFINET diagnostic parameter data items can be transferred at the same time
- The PROFINET IO controller assigns the IP address
- Engineering access using MOVITOOLS[®] MotionStudio via Ethernet TCP/IP
- Inverter diagnostics using a standard browser (e.g. Internet Explorer) via the integrated Web server:
 - Transfer display values
 - DFE32B configuration (after login)

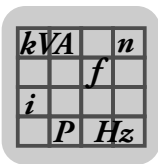

Technical Data of Options

DFE33B EtherNet/IP and Modbus/TCP fieldbus interface option

4.16 DFE33B EtherNet/IP and Modbus/TCP fieldbus interface option

4.16.1 Part number

1821 346 4

4.16.2 Description

The MOVIDRIVE® MDX61B inverter enables you to use the DFE33B option to connect to higher-level automation, project planning and visualization systems via Ethernet (EtherNet/IP and Modbus/TCP protocol) thanks to its powerful, universal fieldbus interface. You can use option DFE33B to communicate directly with the inverters via Ethernet and operate the MOVITOOLS® MotionStudio engineering software to change parameters and IPOS^{plus}® programs. An integrated Web server makes it possible for the user to access diagnostic values quickly and easily using a standard browser (e.g. Internet Explorer).

4.16.3 Electronics data

DFE33B option		
	Application protocols	<ul style="list-style-type: none"> • EtherNet/IP (Ethernet Industrial Protocol) or Modbus/TCP to control and parameterize the inverter. • HTTP (Hypertext Transfer Protocol) for diagnostics using a Web browser. • SMLP (Simple MOVILINK Protocol), protocol used by MOVITOOLS® MotionStudio. • DHCP (Dynamic Host Configuration Protocol) to assign address parameter automatically.
	Port numbers used	<ul style="list-style-type: none"> • 44818 EtherNet/IP (TCP) • 2222 EtherNet/IP (UDP) • 502 Modbus/TCP • 300 SMLP (TCP, UDP) • 80 HTTP • 67 / 68 DHCP
	Ethernet services	<ul style="list-style-type: none"> • ARP • ICMP (ping)
	ISO / OSI layer 1/2 ISO / OSI layer 4/5	Ethernet II TCP/IP and UDP/IP
	Automatic baud rate detection	10 MBaud / 100 MBaud
	Connection technology	2 x RJ45 with integrated switch and autocrossing
	Addressing	4 byte IP address or MAC-ID (00-0F-69-xx-xx-xx)
	Manufacturer ID (Vendor ID)	<ul style="list-style-type: none"> • 013B_{hex} (EtherNet/IP) • "SEW-EURODRIVE" (Modbus/TCP)
	Tools for startup	<ul style="list-style-type: none"> • MOVITOOLS® MotionStudio engineering software version 5.40 or higher. • DBG60B keypad
	Firmware status of MOVIDRIVE® MDX61B	Firmware version 824 854 0.17 or higher (→ display with P076)

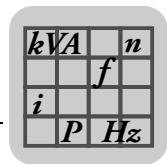

4.16.4 Functions

- EtherNet/IP protocol
- Two RJ45 plug connectors for star or line type cabling
- Up to 10 process data and parameter data items can be transferred at the same time
- Two ways to allocate the IP address:
 1. Using the DBG60B keypad and MOVITOOLS® MotionStudio
 2. Using the DHCP server
- Engineering access using MOVITOOLS® MotionStudio via Ethernet TCP/IP
- Inverter diagnostics using a standard browser (e.g. Internet Explorer) via the integrated Web server:
 - Transfer display values
 - DFE33B configuration (after login)

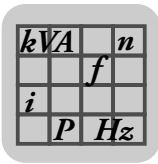

Technical Data of Options

DFE24B EtherCAT[®] fieldbus interface option

4.17 DFE24B EtherCAT[®] fieldbus interface option

4.17.1 Part number

1821 126 7

4.17.2 Description

The MOVIDRIVE[®] MDX61B inverter enables you to use the DFE24B option to connect to higher-level automation, project planning and visualization systems via EtherCAT[®] thanks to its powerful, universal fieldbus interface. You can use the DFE24B option to communicate with the inverters via the EtherCAT[®] master and operate the MOVITOOLS[®] MotionStudio engineering software via EtherCAT[®] to change parameters and IPOS^{plus}[®] programs.

4.17.3 Electronics data

DFE24B option		
	Standards	IEC 61158, IEC 61784-2
	Baud rate	100 Mbaud full duplex
	Connection technology	Two RJ45 plug connectors
	Bus termination	Not integrated because bus termination is automatically activated.
	OSI layer	Ethernet II
	Station address	Setting via EtherCAT [®] master (→ Display with P093)
	XML file name	SEW_DFE24B.xml
	Vendor ID	0x59 (CANopenVendor ID)
	EtherCAT [®] services	<ul style="list-style-type: none"> • CoE (CANopen over EtherCAT[®]) • VoE (Simple MOVILINK[®] Protocol over EtherCAT[®])
	Firmware status of MOVIDRIVE [®] B	824 854 0.18 or higher (→ display with P076)
	Tools for startup	<ul style="list-style-type: none"> • MOVITOOLS[®] MotionStudio engineering software version 5.40 or higher. • DBG60B keypad
	1455419915	

4.17.4 Functions

- EtherCAT[®]
- Two RJ45 plug connectors for line type cabling
- Simultaneous communication of up to 10 process data and parameter data as well as access (Rx, Tx) to 8 IPOS^{plus}[®] variables
- Automatic addressing via EtherCAT[®] master
- Engineering access using MOVITOOLS[®] MotionStudio via EtherCAT[®]

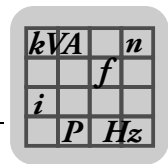

4.18 DFD11B DeviceNet fieldbus interface option

4.18.1 Part number

824 972 5

4.18.2 Description

The MOVIDRIVE® MDX61B inverter in conjunction with the DFD11B option allows connection to higher-level automation, project planning and visualization systems via the open and standardized DeviceNet fieldbus system thanks to the option's high-performance universal fieldbus interface.

The DeviceNet fieldbus interface type DFD11B can be plugged into the fieldbus slot on all MOVIDRIVE® MDX61B units. The DFD11B option enables communication with the machine control for a maximum of 10 process data. You need an EDS file to be able to integrate the DFD11B in the machine control. You can download this file from the SEW homepage in the Software section.

4.18.3 Electronics data

DFD11B option		
<p>DFD11B</p> <p>MOD/Net PIO BIO BUS FAULT</p> <p>0 1</p> <p>NA(5) NA(4) NA(3) NA(2) NA(1) NA(0)</p> <p>DR(1) DR(0) PD(4) PD(3) PD(2) PD(1) PD(0)</p> <p>F3 F2 F1</p> <p>1 2 3 4 5</p> <p>X30</p> <p>1455438859</p>	Communication protocol	Master/slave connection set according to DeviceNet specification version 2.0
	Number of process data words	Can be set via DIP switch: <ul style="list-style-type: none"> • 1 ... 10 process data words • 1 ... 4 process data words with bit-strobe I/O
	Baud rate	125, 250 or 500 kbaud, can be set using DIP switch
	Bus cable length	For thick cable according to DeviceNet specification 2.0 appendix B: <ul style="list-style-type: none"> • 500 m at 125 kbaud • 250 m at 250 kbaud • 100 m at 500 kbaud
	Transmission level	ISO 11 98 - 24 V
	Connection technology	<ul style="list-style-type: none"> • 2-wire bus and 2-wire supply voltage DC 24 V with 5-pole Phoenix terminal • Pin assignment according to DeviceNet specification
	MAC ID	0 ... 63, can be set using DIP switch Max. 64 stations
	Supported services	<ul style="list-style-type: none"> • Polled I/O: 1 ... 10 words • Bit-strobe I/O: 1 ... 4 words • Explicit messages: <ul style="list-style-type: none"> – Get_Attribute_Single – Set_Attribute_Single – Reset – Allocate_MS_Connection_Set – Release_MS_Connection_Set
	Tools for startup	<ul style="list-style-type: none"> • MOVITOOLS® MotionStudio engineering software • DBG60B keypad

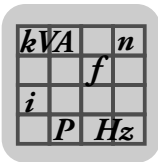

4.19 DFC11B CAN/CANopen fieldbus interface option

4.19.1 Part number

824 317 4

4.19.2 Description

The MOVIDRIVE® MDX61B inverter in conjunction with the DFC11B option allows connection to higher-level automation, project planning and visualization systems via the open and standardized CANopen fieldbus system thanks to the option's high-performance universal fieldbus interface. You can also access parameters and process data using the MOVILINK® protocol designed especially for units from SEW-EURODRIVE.

The DFC11B fieldbus interface type can be plugged into the fieldbus slot on all MOVIDRIVE® MDX61B units. In this way, a second system bus (CAN) on MOVIDRIVE® is made available. The DFC11B option enables communication with the machine control for a maximum of 10 process data. You need an EDS file to be able to integrate the DFC11B in the higher-level CANopen control. You can download this file from the SEW homepage in the Software section.

4.19.3 Electronics data

DFC11B option		
	Communication profile	<ul style="list-style-type: none"> SEW-MOVILINK® CANopen CAN Layer 2
	Number of process data words	1 ... 10 process data words
	Baud rate	Setting using parameter P894: 125 kbaud / 250 kbaud / 500 kbaud / 1 Mbaud
	Connection technology	9-pole Sub-D plug connector X30 (plug assigned to CIA standard) or terminal X31
	Permitted cable cross section X31 (CAN bus connection)	One core per terminal: 0.20 ... 2.5 mm ² (AWG24 ... 12) Two cores per terminal: 0.25 ... 1 mm ² (AWG22 ... 17)
	Terminating resistor	120 Ω (set using DIP switch S1-R)
	Addressing	Setting via parameter P891 (SBus MOVILINK®) or P896 (CANopen)
	Tools for startup	<ul style="list-style-type: none"> MOVITOOLS® MotionStudio engineering software DBG60B keypad

4.19.4 Functions

- CAN Layer 2 and communication profile MOVILINK® or CANopen
- Electrical isolation via optocoupler

	INFORMATION
	If electrical isolation is not required, the CAN-Bus can be connected directly to the basic unit at X12:SC11/SC12 without the DFC11B option. This does not effect the functionality.

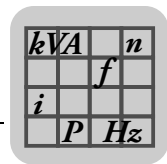

4.20 DRS11B synchronous operation card option

4.20.1 Part number

824 672 6

4.20.2 Description

The DRS11B option enables a group of motors to run in angular synchronous operation or in an adjustable proportional relationship. For detailed information, refer to the "DRS11B Synchronous Operation Card" manual, which can be ordered from SEW-EURODRIVE. The basis for synchronous operation is the continuous comparison of the rotor angle positions of the master and slave motors. The motors must be equipped with encoders. The DRS11B option is plugged into the expansion slot.

Option DRS11B			
	Binary inputs	X40:1...X40:6	EINGØ...EING5: Isolated (optocoupler) PLC compatible (EN 61131) Internal resistance $R_i \approx 3 \text{ k}\Omega$, $I_E \approx \text{DC } 10 \text{ mA}$ Sampling time 5 ms
	Signal level		DC+13 V...+30 V = "1" = Contact closed DC- 3 V...+5 V = "0" = contact open
	Function		Fixed assignment with: <ul style="list-style-type: none"> EINGØ = Free-running INP1 = Offset 1 INP2 = Offset 2 INP3 = Offset 3 INP4 = IPOS^{plus}® variable H477.0 INP5 = IPOS^{plus}® variable H477.1
	Binary outputs	X40:9/X40:10	OUTPØ/OUTP1: PLC compatible (EN 61131-2) Response time 5 ms
	Signal level		"0" = DC 0 V "1" = DC+24 V Important: Do not apply any external voltage!
	Function		Fixed assignment with: <ul style="list-style-type: none"> OUTPØ = IPOS^{plus}® variable H476.0 OUTP1 = IPOS^{plus}® variable H476.1 $I_{\text{max}} = \text{DC } 50 \text{ mA}$, short-circuit proof, protected against external voltage to DC 30 V
	Reference terminals	X40:11 X40:7	DGND: Reference potential for binary signals DCOM: Reference potential for binary inputs X40:1...X40:6 (INPØ...INP5) VO24: Voltage output DC +24 V, max. DC 100 mA
	Voltage output	X40:8	
	Distance encoder input Encoder power supply	X41:	Max. 200 kHz, signal level according to RS422 or sin/cos DC +24 V, $I_{\text{max}} = 650 \text{ mA}^{1)}$ 9-pin D-sub socket
	Master encoder input Encoder power supply	X42:	Max. 200 kHz, signal level according to RS422 or sin/cos DC+24 V, $I_{\text{max}} = \text{DC } 650 \text{ mA}$ 9-pin D-sub socket
Encoder simulation output	X43:	Signal level to RS422 9-pin D-sub connector	
Voltage input	X44:1 X44:2 X44:3	GND DC+24 V supply voltage for binary outputs X40:9/X40:10 and encoder GND	
Permitted cable cross-section		One core per terminal: 0.08 ... 1.5 mm ² (AWG28 ... 16) Two cores per terminal: 0.25 ... 1 mm ² (AWG22 .. 17)	

1) Total current load (X41 and X42) of the DC 24 V encoder supply $\leq \text{DC } 650 \text{ mA}$

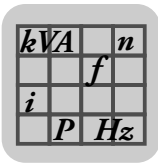

Technical Data of Options

DFS11B fieldbus interface option PROFIBUS DP-V1 with PROFIsafe

4.21 DFS11B fieldbus interface option PROFIBUS DP-V1 with PROFIsafe

4.21.1 Part number

1820 962 9

4.21.2 Description

MOVIDRIVE[®] B can be equipped with the 12 Mbaud fieldbus interface DFS11B for the serial bus system PROFIBUS-DP-V1 with PROFIsafe. In addition to cyclical and acyclical data exchange, safety-oriented communication takes place that allows to switch a safe F-DO output. The device master data (GSD) and type files for MOVIDRIVE[®] B are available from the SEW homepage (<http://www.sew-eurodrive.de>) under "Software" to help with project planning and facilitate startup.

For more detailed information, refer to the "DFS11B Fieldbus Interface PROFIBUS DP-V1 with PROFIsafe" manual. You can order this manual from SEW-EURODRIVE.

4.21.3 Electronics data

DFS11B option		
<p>DFS11B</p> <p>R FS</p> <p>BF FDO</p> <p>GO</p> <p>F-ADDRESS</p> <p>20 21 22 23 24 25 26 27 28 29</p> <p>X30</p> <p>20 21 22 23 24 25 26 AS</p> <p>0 1</p> <p>1455484171</p>	PROFIBUS protocol options	PROFIBUS DP and DP-V1 to IEC 61158
	Automatic baud rate detection	9.6 kbaud ... 12 Mbaud
	Connection technology	<ul style="list-style-type: none"> 9-pin D-sub socket Pin assignment acc. to IEC 61158
	Bus termination	Not integrated, implement using suitable PROFIBUS plug with terminating resistors that can be switched on.
	Station address	1 ... 125, adjustable via DIP switches
	GSD file name	SEW_600C.GSD
	DP ID number	600C = 24588 _{hex}
	Diagnostics data	<ul style="list-style-type: none"> Max. 8 bytes Standard diagnostics: 6 bytes
	Tools for startup	<ul style="list-style-type: none"> MOVITOOLS[®] MotionStudio engineering software DBG60B keypad
	F address	1 ... 1022 DIP switch for setting the failsafe address
	Ambient temperature	0 ... 55 °C

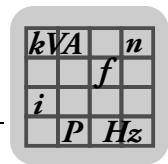

4.21.4 Safety part

Safety characteristics	
Maximum possible safety class	<ul style="list-style-type: none"> SIL 3 according to EN 61508 Category 4 according to EN 954-1 Performance level e according to EN ISO 13849-1
System structure	2 channels with diagnostics (1002D)
Operating mode selection	"High demand" rate according to EN 61508
Probability of dangerous failure per hour (PFH value)	<1.00E-09 (1 FIT)
Proof test interval (EN61508)	10 years, after which the component must be replaced with a new one
Repair time	100 hours
Safe condition	Value "0" for all safety-oriented F-DO process values (output disabled)
Safe output	
P-M switch (from load voltage supply)	DC 24 V output according to EN 61131-2, protected against short circuits and overloads
Rated current	1A
Leakage current ("0" signal)	Typically -2 mA (with 2 V / 1 kΩ load resistance) (Note: Current flows from F-DO_M to F-DO_P)
Internal voltage drop (P and M output)	Max. 3 V
Short circuit protection	Electronic, response value: 2.8 A ... 9 A
Overload protection	Response value: 1.4 A ... 1.6 A
Load resistance range	24 kΩ ... 1 kΩ
Voltage limitation when switching off inductive loads	Typically -70 V
Response time (command via PROFIsafe → output switches)	≤ 25 ms
Maximum line length	30 m

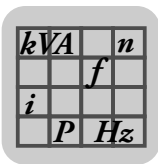

Technical Data of Options

DFS12B fieldbus interface option PROFIBUS DP-V1 with PROFIsafe

4.22 DFS12B fieldbus interface option PROFIBUS DP-V1 with PROFIsafe

4.22.1 Part number

1820 963 7

4.22.2 Description

MOVIDRIVE® B can be equipped with the 12 Mbaud fieldbus interface DFS12B for the serial bus system PROFIBUS DP-V1 with PROFIsafe. In addition to cyclical and acyclical data exchange, safety-oriented communication takes place in conjunction with the DCS21B option. The device master data (GSD) and type files for MOVIDRIVE® B are available from the SEW homepage (<http://www.sew-eurodrive.de>) under "Software" to help with project planning and facilitate startup.

For more detailed information, refer to the "DFS12B Fieldbus Interface PROFIBUS DP-V1 with PROFIsafe" manual. You can order this manual from SEW-EURODRIVE.

4.22.3 Electronics data

DFS12B option		
	PROFIBUS protocol options	PROFIBUS DP and DP-V1 to IEC 61158
	Automatic baud rate detection	9.6 kbaud ... 12 Mbaud
	Connection technology	<ul style="list-style-type: none"> 9-pin D-sub socket Pin assignment acc. to IEC 61158
	Bus termination	Not integrated, implement using suitable PROFIBUS plug with terminating resistors that can be switched on.
	Station address	1 ... 125, adjustable via DIP switches
	GSD file name	SEW_600C.GSD
	DP ID number	600C = 24588 _{hex}
	Diagnostics data	<ul style="list-style-type: none"> Max. 8 bytes Standard diagnostics: 6 bytes
	Tools for startup	<ul style="list-style-type: none"> MOVITOOLS® MotionStudio engineering software DBG60B keypad
	F address	The failsafe address is set using the DCS21B option
	Ambient temperature	0 ... 55 °C

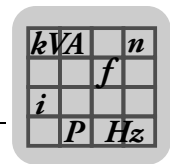

4.23 DFS21B fieldbus interface option PROFINET IO with PROFIsafe

4.23.1 Part number

1821 183 6

4.23.2 Description

The MOVIDRIVE® MDX61B inverter enables you to use the DFS21B option to connect to higher-level automation, project planning and visualization systems via Ethernet (PROFINET/IO RT protocol) thanks to its powerful, universal fieldbus interface. In addition to cyclical and acyclical data exchange, safety-oriented communication takes place that allows to switch a safe F-DO output. You can use option DFS21B to communicate directly with the inverters via Ethernet and operate the MOVITOOLS® MotionStudio engineering software to change parameters and IPOS^{plus}® programs. An integrated Web server makes it possible for the user to access diagnostic values quickly and easily using a standard browser (e.g. Internet Explorer).

For more detailed information, refer to the "DFS21B Fieldbus Interface PROFINET IO with PROFIsafe" manual. You can order this manual from SEW-EURODRIVE.

4.23.3 Electronics data

DFS21B option	
<p>1455523979</p>	Application protocols <ul style="list-style-type: none"> • PROFINET IO (Ethernet frames with frame identification 8892_{hex}) to control and parameterize the inverter. • HTTP (Hypertext Transfer Protocol) for diagnostics using a Web browser. • SMLP (Simple MOVILINK Protocol), protocol used by MOVITOOLS® MotionStudio.
	Port numbers used <ul style="list-style-type: none"> • 300 (SMLP) • 80 (HTTP)
	Ethernet services <ul style="list-style-type: none"> • ARP • ICMP (ping)
	ISO / OSI layer 2 <p>Ethernet II</p>
	Baud rate <p>100 Mbaud in full duplex mode</p>
	Connection technology <p>Two RJ45 plug connectors with integrated switch and auto-crossing</p>
	Addressing <p>4 byte IP address or MAC-ID (00:0F:69:xx:xx:xx)</p>
	Manufacturer ID (Vendor ID) <p>010A_{hex}</p>
	Tools for startup <ul style="list-style-type: none"> • MOVITOOLS® MotionStudio engineering software version 5.40 or higher. • DBG60B keypad
	F address <p>1 ... 1022 DIP switch for setting the failsafe address</p>
	Firmware status of MOVIDRIVE® MDX61B <p>Firmware version 824 854 0.17 or higher (→ display with P076)</p>
	Ambient temperature <p>0 ... 55 °C</p>

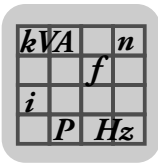

4.23.4 Safety part

Safety characteristics	
Maximum possible safety class	<ul style="list-style-type: none"> SIL 3 according to EN 61508 Category 4 according to EN 954-1 Performance level e according to EN ISO 13849-1
System structure	2 channels with diagnostics (1oo2D)
Operating mode selection	"High demand" rate according to EN 61508
Probability of dangerous failure per hour (PFH value)	<1.00E-09 (1 FIT)
Proof test interval (EN61508)	10 years, after which the component must be replaced with a new one
Repair time	100 hours
Safe condition	Value "0" for all safety-oriented F-DO process values (output disabled)
Safe output	
P-M switch (from load voltage supply)	DC 24 V output according to EN 61131-2, protected against short circuits and overloads
Rated current	1A
Leakage current ("0" signal)	Typically -2 mA (with 2 V / 1 kΩ load resistance) (Note: Current flows from F-DO_M to F-DO_P)
Internal voltage drop (P and M output)	Max. 3 V
Short circuit protection	Electronic, response value: 2.8 A ... 9 A
Overload protection	Response value: 1.4 A ... 1.6 A
Load resistance range	24 kΩ ... 1 kΩ
Voltage limitation when switching off inductive loads	Typically -70 V
Response time (command via PROFIsafe® → output switches)	≤ 25 ms
Maximum line length	30 m

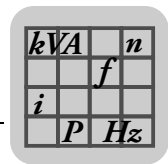

4.24 DFS22B fieldbus interface option PROFINET IO with PROFIsafe

4.24.1 Part number

1821 184 4

4.24.2 Description

The MOVIDRIVE® MDX61B inverter enables you to use the DFS22B option to connect to higher-level automation, project planning and visualization systems via Ethernet (PROFINET/IO RT protocol) thanks to its powerful, universal fieldbus interface. In addition to cyclical and acyclical data exchange, safety-oriented communication takes place in conjunction with the DCS21B option. You can use option DFS22B to communicate directly with the inverters via Ethernet and operate the MOVITOOLS® MotionStudio engineering software to change parameters and IPOS^{plus}® programs. An integrated Web server makes it possible for the user to access diagnostic values quickly and easily using a standard browser (e.g. Internet Explorer).

For more detailed information, refer to the "DFS22B Fieldbus Interface PROFINET IO with PROFIsafe" manual. You can order this manual from SEW-EURODRIVE.

4.24.3 Electronics data

DFS22B option	
<p>1455645707</p>	Application protocols <ul style="list-style-type: none"> • PROFINET IO (Ethernet frames with frame identification 8892_{hex}) to control and parameterize the inverter. • HTTP (Hypertext Transfer Protocol) for diagnostics using a Web browser. • SMLP (Simple MOVILINK Protocol), protocol used by MOVITOOLS® MotionStudio.
	Port numbers used <ul style="list-style-type: none"> • 300 (SMLP) • 80 (HTTP)
	Ethernet services <ul style="list-style-type: none"> • ARP • ICMP (ping)
	ISO / OSI layer 2 <p>Ethernet II</p>
	Baud rate <p>100 Mbaud in full duplex mode</p>
	Connection technology <p>Two RJ45 plug connectors with integrated switch and auto-crossing</p>
	Addressing <p>4 byte IP address or MAC-ID (00:0F:69:xx:xx:xx)</p>
	Manufacturer ID (Vendor ID) <p>010A_{hex}</p>
	Tools for startup <ul style="list-style-type: none"> • MOVITOOLS® MotionStudio engineering software version 5.40 or higher. • DBG60B keypad
	F address <p>The failsafe address is set using the DCS21B option</p>
Firmware status of MOVIDRIVE® MDX61B <p>Firmware version 824 854 0.17 or higher (→ display with P076)</p>	
Ambient temperature <p>0 ... 55 °C</p>	

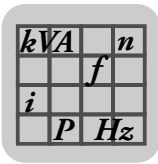

4.25 MOVISAFE[®] DCS21B/31B safety module option

4.25.1 Part numbers

- DCS21B complete with prefabricated cable DAE34B (CAN bus connection between DCS21B X86 and DFS21B X31): 1821 895 4
- DCS21B without prefabricated cable: 1820 392 2
- DCS31B: 1820 958 0

4.25.2 Description

The DCS21B and DCS31B options of the MOVISAFE[®] series are designed as expansion options for functional safety. They are capable of performing various drive monitoring functions, such as standstill, speed, direction of rotation or position monitoring. Additionally, sensor signals can be processed via safe inputs and outputs and MOVIDRIVE[®] B can be switched off according to stop categories 0, 1, or 2.

To being able to communicate with a higher-level safety controller in a safety-oriented manner, the DCS21B option must be used together with the DFS12B fieldbus interface (PROFIBUS DP-V1) or DFS22B (PROFINET IO). The DCS21B/31B option is plugged into the expansion slot.

For detailed information, refer to the "DCS21B/31B Safety Monitor" manual, which you can order from SEW-EURODRIVE.

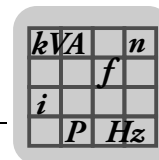

Overview of pre-fabricated cables

For connecting an encoder to both MOVIDRIVE® B and the DCS21B/31B option, you can order prefabricated cables from SEW-EURODRIVE.

Prefabricated cables allow you to split the encoder signals and to connect the encoder to the options DCS21B/31B **and** DEH11B/21B or DEU21B.

Encoder cables				
Type	DCS units		Part number	Length
DAE31B ¹⁾	SIN/COS splitting to DEH X15 - DCS X84/X85		1810 053 8	300 mm ± 30 mm (1 ft ± 0.1 ft)
DAE32B ¹⁾	SSI absolute splitting to X62 - DCS X84/X85		1810 625 0	
DAE33B ¹⁾	Conversion from D-sub 15-pole Hiperface® encoder to D-sub 9-pole DCS card X84/85		1810 785 0	
DAE34B ²⁾	CAN cable (still used for cards with S no. > 1500)		1821 307 3	150 mm ± 30 mm (0.5 ft ± 0.1 ft)
Type	DCS units	Inverter → DCSB X84/85	Part number	Length
DAE40B	SIN/COS splitting Asynchronous	DEH11B → X14 DEU21B → X14 DER11B → X14	1811 601 9	200 mm to 6 m (0.66 ft – 19.7 ft)
DAE41B	SIN/COS splitting Synchronous	DEU21B → X14 DER11B → X14	1811 468 7	
DAE42B	SIN/COS splitting Asynchronous	DEH11B → X15 DEU21B → X15	1811 602 7	
DAE43B	SIN/COS splitting Synchronous	DEH11B → X15 DEU21B → X15	1811 467 9	
DAE44B	Splitting SSI 9-pole	DEH21B → X62	1810 625 0	
DAE45B	Splitting SSI	DEU21B → X15	1811 709 0	
DAE47B	Sin/cos encoder adapter 15-pin to 9-pin	Cable with resistors	1811 604 3	
DAE48B	SSI encoder adapter 9-pin to 9-pin	Cable with 1 x resistor	1811 917 4	
DAE49B	SSI encoder adapter 15-pin to 9-pin	Cable with 1 x resistor	1811 918 2	

1) Can only be used for DCS21B/31B with serial number ≤ 001499

2) CAN bus connection between X86 of option DCS21B and X31 of option DFS12B/22B.

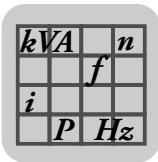

4.25.3 Electronics data

DCS21B/31B option	
<p style="text-align: center;">DCS21B</p> <p style="text-align: center;">1455652235</p>	<p style="text-align: center;">DCS31B</p> <p style="text-align: center;">1455668107</p>
	<p>LED alarm/error LED watchdog LED system B LED system A</p> <p>X80: Power supply connection</p> <p>X81: Connection binary inputs</p> <p>X82: Connection of binary outputs DO0, DO1</p> <p>X83: Terminal for binary output DO2</p> <p>X84: Connection of incremental, sin/cos or absolute encoder (encoder 1)</p> <p>X85: Connection of incremental, sin/cos or absolute encoder (encoder 2)</p> <p>X86: CAN bus connection (only for DCS21B)</p> <p>X87: Connection for service interface</p>

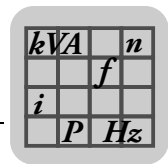

4.26 MOVI-PLC® basic DHP11B controller option

4.26.1 Part numbers

The MOVI-PLC® basic DHP11B controller is available in 3 variants, which differ in the modules available from a range of libraries.

Part number	MOVI-PLC® basic DHP11B unit variant	Description
1820 472 4	DHP11B-T0	MOVI-PLC® basic controller
1820 822 3	DHP11B-T1	Application version I (in addition to version T0, enables additional functions including electronic cam and synchronous operation)
1820 823 1	DHP11B-T2	Application version II (in addition to version T1, enables additional functions including handling)

4.26.2 Description

MOVI-PLC® is a series of controllers available from SEW-EURODRIVE. MOVI-PLC® can be programmed by users according to IEC 61131-3 and PLCopen.

The MOVI-PLC® basic DHP11B controller is equipped with a PROFIBUS DP-V1 slave interface, two SBus interfaces (CAN), RS485, and eight digital inputs/outputs, five of which are interrupt-capable. MOVI-PLC® basic DHP11B can control 12 units at the same time (MOVIDRIVE® B/compact, MOVITRAC® B, MOVIAxis®, MOVIMOT®).

4.26.3 Electronics data

MOVI-PLC® basic DHP11B option		
	Status displays	LEDs for I/O voltage supply, firmware, program, PROFIBUS, system buses
	Fieldbus	<ul style="list-style-type: none"> PROFIBUS DP and DP-V1 to IEC 61158 Automatic baud rate detection from 9.6 kbaud to 12 Mbaud Bus connection implemented with suitable connector GSD file SEW_6007.GSD DP ident. number 6007_{hex} (24579_{dec}) Maximum 32 process data
	System bus	<ul style="list-style-type: none"> 2 system buses (CAN) to control 12 inverters and CANopen I/O modules CAN layer 2 (SCOM cyclic, acyclic) or via the SEW MOVILINK® protocol Baud rate: 125 kbaud ... 1 Mbaud External bus terminator Address range: 0 ... 127
	Engineering	Via RS485, PROFIBUS and the system buses
	Panel operation	Via RS485 and CAN 2 (in preparation)
	Connection technology	<ul style="list-style-type: none"> PROFIBUS: 9-pole D-sub connector according to IEC 61158 System buses and I/Os: plug-in terminals RS485: RJ10
	Binary inputs/outputs	8 I/Os to IEC 61131-2; can be configured as inputs or outputs. Five are interrupt-capable
	Memory	<ul style="list-style-type: none"> Program: 512 kB Data: 128 kB Retain: 24 kB
	Tools for startup	MOVITOOLS® MotionStudio with integrated PLC Editor (Programming languages IL, ST, LD, FBD, CFC, SFC; libraries to optimize control of the inverters)

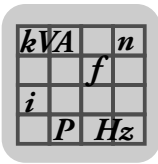

4.27 OST11B option

4.27.1 Part number

1820 544 5

4.27.2 Description

Option OST11B provides an additional RS485 interface (COM2) for MOVI-PLC[®] *basic* DHP11B in terminal design or as an engineering interface. Only use option OST11B in conjunction with MOVI-PLC[®] *basic* DHP11B.

When the MOVI-PLC[®] *basic* DHP11B option is plugged into the fieldbus slot, option OST11B is plugged into the encoder slot. When the MOVI-PLC[®] *basic* DHP11B option is plugged into the expansion slot, option OST11B is installed in the expansion slot above the option MOVI-PLC[®] *basic* DHP11B.

4.27.3 Electronics data

OST11B option		
<p>OST 11B</p> <p>X35</p> <p>Y/R</p> <p>CTRL</p> <p>1455757707</p>	RS485 interface COM2 X35:1 ... X35:4 X36:1 ... X36:3	<ul style="list-style-type: none"> For connection of an Engineering PC, a DOP11A/B operator terminal or a gearmotor with integrated frequency inverter MOVIMOT[®] I/O standard, 57.6 kBd, max. total cable length 200 m, integrated dynamic terminating resistor permanently installed
	Potential level	COM2 is isolated from the MOVI-PLC [®] <i>basic</i> DHP11B controller.

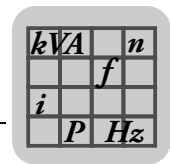

4.28 DHE/DHF/DHR21 and DHE/DHF/DHR41B controller option

Three types of DH.21B/41B controllers are available, which differ in the fieldbus interfaces:

DH.21B/41B type	Fieldbus interfaces
DHE21B/41B	Ethernet TCP/IP, UDP
DHF21B/41B	Ethernet TCP/IP, UDP, PROFIBUS DP-V1, DeviceNet
DHR21B/41B	Ethernet TCP/IP, UDP, PROFINET, EtherNet/IP, ModbusTCP/IP

4.28.1 Description

Freely programmable motion and logic controller (MOVI-PLC®)

The controller can be operated as freely programmable motion and logic controller MOVI-PLC® when using SD cards of the type OMH41B. MOVI-PLC® is a series of programmable motion and logic controllers. It allows drive solutions, logic processes and sequence controls to be automated simply and efficiently using IEC 61131-3 compliant programming languages.

- MOVI-PLC® is a **universal** solution because it is able to control the entire portfolio of SEW inverters and offers a simple upgrade to a more powerful MOVI-PLC® version due to the fact that all possible programs can be executed.
- MOVI-PLC® is **scalable** due to several different hardware platforms (standard, advanced, etc.) and modular software concepts (libraries for numerous applications).
- MOVI-PLC® is **powerful** due to extensive technologies (such as electronic cam, synchronous operation) and the control of demanding applications (such as material handling).

MOVI-PLC® standard performance class

- DH.21B controllers enable coordinated single axis movements and integration of external inputs/outputs as well as Drive Operator Panels (DOP). The DH.21B.. option is therefore suitable for use as a module controller or stand-alone controller for machines of medium complexity.

MOVI-PLC® advanced performance class

- The DH.41B controller is characterized by a greater variety of interfaces and a higher performance level, which allows complex calculations and interpolated movements, for example. The DH.41B option is therefore suitable for the automation of cells and machines. The integrated Ethernet interface enables direct connection of the DH.41B controller to the control level.

Configurable application controller (CCU)

The controller can be used as configurable application controller (CCU) by using SD cards of the type OMC41B. Only standardized application modules created by SEW-EURODRIVE can be executed. The application modules can be started up quickly and conveniently by graphical configuration. A defined process data interface provides this functionality to a higher-level controller. A process data monitor with control mode is available to support the startup procedure.

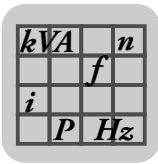

Technical Data of Options

DHE/DHF/DHR21 and DHE/DHF/DHR41B controller option

CCU standard performance class

The "CCU standard" performance class is intended for application modules with single-axis functionality and medium response times. A maximum of 16 axes can be connected to a configurable application controller. The following application modules are available and can be started up using the *AxisConfigurator* tool.

- Speed specification
- Cam positioning
- Bus positioning with 6 process data
- Single-axis universal module

CCU advanced performance class

The "CCU advanced" performance class is intended for application modules with single-axis and multi-axis functionality and fast response times. The following application modules are available:

- Single-axis functionality:
 - Speed specification
 - Cam positioning
 - Bus positioning with 6 process data words
 - Single-axis universal module
- Multi-axis functionality:
 - SyncCrane
 - Energy-efficient SRU

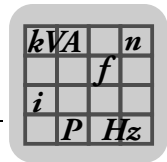

4.28.2 DHE21B/41B electronics data

DHE21B/41B option		
<p>1455764363</p>	Part number	<ul style="list-style-type: none"> DHE21B option: 1823 607 3 DHE41B option: 1821 160 7
	Electrical supply	<p>The following applies to all units (MDX, MX, compact controller):</p> <ul style="list-style-type: none"> You have to supply the binary inputs and outputs separately with DC 24 V (X31:1/2). <p>Installed in MOVIDRIVE® MDX61B:</p> <ul style="list-style-type: none"> Power consumption: $P_{max} = 6.8 \text{ W}$ Option DHE21B/41B is supplied by MOVIDRIVE® MDX61B via backplane connector. In the case of disconnection from the power supply, continued function is guaranteed by the DC 24 backup mode (external DC 24 V supply to X10:9/10 of MOVIDRIVE® MDX61B required). <p>Installed in the MOVIAXIS® master module (MXM):</p> <ul style="list-style-type: none"> Power consumption: $P_{max} = 8.5 \text{ W}$ $U = \text{DC } 24 \text{ V } (-15 \% / +20 \%)$ $I_{max} = 600 \text{ mA}$ Option DHE21B/41B can be supplied from the MOVIAXIS® switched-mode power supply (MXS) or from an external voltage source. To do so, connect X5 between the individual units. If the DHE21B/41B option is supplied with DC 24 V from the MOVIAXIS® switched-mode power supply, then the function of the DHE21B/41B option is ensured when power supply is switched off (external DC 24 V supply at X16 of the MOVIAXIS® switched-mode power supply).
	Potential levels	<p>Option DHE21B/41B has the following potential levels:</p> <ul style="list-style-type: none"> Potential control / CAN 1 / COM1 Potential COM2 Potential binary inputs and outputs Potential system bus CAN 2
	Memory	<ul style="list-style-type: none"> Retain data: 32 kB System variables (retain): 8 kB <p>Program memory:</p> <ul style="list-style-type: none"> DHE21B: 2 MB (for application program, incl. IEC libraries) DHE41B: 6 MB (for user program, incl. IEC libraries) <p>Data memory:</p> <ul style="list-style-type: none"> DHE21B: 4 MB (for IEC application) DHE41B: 8 MB (for IEC application)

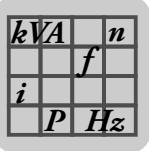

Technical Data of Options

DHE/DHF/DHR21 and DHE/DHF/DHR41B controller option

DHE21B/41B option	
CAN 2 system bus X32:1 ... X32:3 CAN 1 system bus X33:1 ... X33:3	<ul style="list-style-type: none"> System bus CAN 1 and CAN 2 to CAN specification 2.0, parts A and B, transmission technology to ISO 11898 The CAN 2 system bus is electrically isolated Max. 64 stations per CAN system bus Max. 64 SCOM transmit objects / 32 receive objects per CAN system bus Address range 0 – 127 Baud rate: 125 kBd - 1 MBd If X32 or X33 is the bus terminator, you must connect a terminating resistor (120 Ω) externally. You can remove connector X32 or X33 without interrupting the system bus. The system bus can be run in layer 2 (SCOM cyclic, acyclic) or in accordance with the SEW MOVILINK® protocol.
Ethernet 1 X36	System bus, reserved
Ethernet 2 X37	<ul style="list-style-type: none"> TCP/IP Connection options: Engineering PC, other controller, Intranet
USB	USB 1.0 for connecting an engineering PC (in preparation)
RS485 interface COM1/ 2 X34:1 ... X34:4	<ul style="list-style-type: none"> For connection of a DOP11A/B operator terminal or a gearmotor with integrated MOVIMOT® frequency inverter I/O standard, 57.6 / 9.6 kBd, max. total cable length 200 m Dynamic terminating resistor with fixed installation
SD memory card	<ul style="list-style-type: none"> PC-readable Includes: <ul style="list-style-type: none"> Firmware IEC program Data At least 128 MB memory Designs, part numbers, and functions: <ul style="list-style-type: none"> OMH41B-T0: 1821 204 2 Functions: Handling of speed control, positioning, e.g. with the MPLCMotion_MDX library OMH41B-T1: 1821 205 0 Functions: Additional: cam disk, electronic gear, cam controller, for example OMH41B-T2: 1821 206 9 Functions: Additional: material handling, for example
Engineering	<p>Engineering takes place via one of the following interfaces:</p> <ul style="list-style-type: none"> Ethernet 2 (X37) In preparation: USB (X35) <p>Engineering for all SEW components connected to the MOVI-PLC® <i>advanced</i> DHE41B control card can be performed using the MOVI-PLC® <i>advanced</i> DHE41B control card.</p> <p>Engineering of the MOVI-PLC® <i>advanced</i> DHE41B controller cannot be performed via the inverters.</p> <ul style="list-style-type: none"> MOVITOOLS® MotionStudio engineering software with PLC Editor

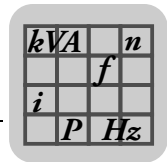

4.28.3 DHF21B/41B electronics data

	INFORMATION
	For connections identical with DHE41B, refer to the "DHE41B electronics data" section.

DHF21B/41B option		
<p style="font-size: small; margin-top: 10px;">1455767819</p>	Part number	<ul style="list-style-type: none"> DHF21B: 1823 608 1 DHF41B: 1821 161 5
	Electrical supply	Installed in MOVIDRIVE® MDX61B: <ul style="list-style-type: none"> Power consumption: $P_{max} = 8 \text{ W}$ Installed in the MOVIAXIS® master module (MXM): <ul style="list-style-type: none"> Power consumption: $P_{max} = 10 \text{ W}$
	Potential levels	Option DHF21B/41B has the following potential levels: <ul style="list-style-type: none"> Potential control / CAN 1 / COM1 Potential COM2 Potential binary inputs and outputs Potential system bus CAN 2 Potential PROFIBUS
	PROFIBUS connection X30P:1 – X30P:9	Via 9-pin D-sub connector, pin assignment to IEC 61158
	Bus termination	Not integrated. Implement bus termination with suitable PROFIBUS connector with switchable terminating resistors.
	Automatic baud rate detection	9.6 kBd – 12 MBd
DeviceNet connection X30D:1 – X30D:5	<ul style="list-style-type: none"> 2-wire bus and 2-wire supply voltage DC 24 V with 5-pole Phoenix terminal Pin assignment according to DeviceNet specification 	

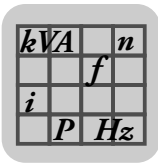

Technical Data of Options

DHE/DHF/DHR21 and DHE/DHF/DHR41B controller option

4.28.4 DHR21B/41B electronics data

	INFORMATION
	<p>Connections identical with those of the DHE21B/41B and DHF21B/41B options are described chapters "DHE21B/41B option" and "DHF21B/41B option".</p>

DHR21B/41B option									
	<table border="0"> <tr> <td style="vertical-align: top; padding-right: 10px;">Part number</td> <td> <ul style="list-style-type: none"> • DHR21B: 1823 610 3 • DHR41B: 1821 632 3 </td> </tr> <tr> <td style="vertical-align: top; padding-right: 10px;">Electrical supply</td> <td> <p>Installed in MOVIDRIVE® MDX61B:</p> <ul style="list-style-type: none"> • Power consumption: $P_{max} = 9.5\text{ W}$ <p>Installed in the MOVIAXIS® master module (MXM):</p> <ul style="list-style-type: none"> • Power consumption: $P_{max} = 12\text{ W}$ </td> </tr> <tr> <td style="vertical-align: top; padding-right: 10px;">Ethernet connection X30-1, X30-2</td> <td> <p>Via RJ45 socket, pin assignment according to IEC 11801</p> <p>Integrated Ethernet switch with autocrossing and autonegotiation functionality.</p> </td> </tr> <tr> <td style="vertical-align: top; padding-right: 10px;">Engineering</td> <td> <p>Additional engineering access via PROFINET, EtherNet/IP and Modbus TCP/IP interface (X30:1/2)</p> </td> </tr> </table>	Part number	<ul style="list-style-type: none"> • DHR21B: 1823 610 3 • DHR41B: 1821 632 3 	Electrical supply	<p>Installed in MOVIDRIVE® MDX61B:</p> <ul style="list-style-type: none"> • Power consumption: $P_{max} = 9.5\text{ W}$ <p>Installed in the MOVIAXIS® master module (MXM):</p> <ul style="list-style-type: none"> • Power consumption: $P_{max} = 12\text{ W}$ 	Ethernet connection X30-1, X30-2	<p>Via RJ45 socket, pin assignment according to IEC 11801</p> <p>Integrated Ethernet switch with autocrossing and autonegotiation functionality.</p>	Engineering	<p>Additional engineering access via PROFINET, EtherNet/IP and Modbus TCP/IP interface (X30:1/2)</p>
	Part number	<ul style="list-style-type: none"> • DHR21B: 1823 610 3 • DHR41B: 1821 632 3 							
	Electrical supply	<p>Installed in MOVIDRIVE® MDX61B:</p> <ul style="list-style-type: none"> • Power consumption: $P_{max} = 9.5\text{ W}$ <p>Installed in the MOVIAXIS® master module (MXM):</p> <ul style="list-style-type: none"> • Power consumption: $P_{max} = 12\text{ W}$ 							
	Ethernet connection X30-1, X30-2	<p>Via RJ45 socket, pin assignment according to IEC 11801</p> <p>Integrated Ethernet switch with autocrossing and autonegotiation functionality.</p>							
Engineering	<p>Additional engineering access via PROFINET, EtherNet/IP and Modbus TCP/IP interface (X30:1/2)</p>								
<p>2859931531</p>									

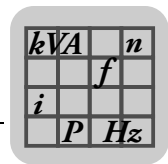

4.29 BST safety-related brake module option

4.29.1 Part numbers

The safety-related brake module is available in three variants:

Type designation	Part number	Approved SEW disk brakes
BST 0.6S-460V-00	0 829 971 4	All brake coils with a brake coil voltage of AC 460 V and a coil power ≤ 120 W. Several brake coils can be connected for redundant systems. In this case, the total power must not exceed 120 W.
BST 0.7S-400V-00	1 300 077 2	All brake coils with a brake coil voltage of AC 400 V and a coil power ≤ 120 W. Several brake coils can be connected for redundant systems. In this case, the total power must not exceed 120 W.
BST 1.2S-230V-00	1 300 133 7	All brake coils with a brake coil voltage of AC 230 V and a coil power ≤ 120 W. Several brake coils can be connected for redundant systems. In this case, the total power must not exceed 120 W.

4.29.2 Description

- The safety-relevant BST brake module enables the connection of an external fail-safe safety switching device/safety controller. The safety switching device disconnects the safe control voltage $V_{24\text{ V safe}}$ when a connected control device (e.g. emergency stop device) is activated.
- Disconnecting the safe control voltage $V_{24\text{ V safe}}$ means the connected brake is disconnected from the power supply. The power supply required for releasing the connected brake is interrupted safely.
- Instead of separating the brake control galvanically from the power supply using contactors or switches, the disconnection procedure described here prevents the power semiconductors in the safety-relevant BST brake module from being activated, in this way ensuring safe disconnection. This means that all connected brakes are de-energized although the supply voltage is still present at the safety-relevant BST brake module.

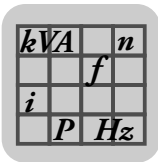

4.29.3 Electronics data

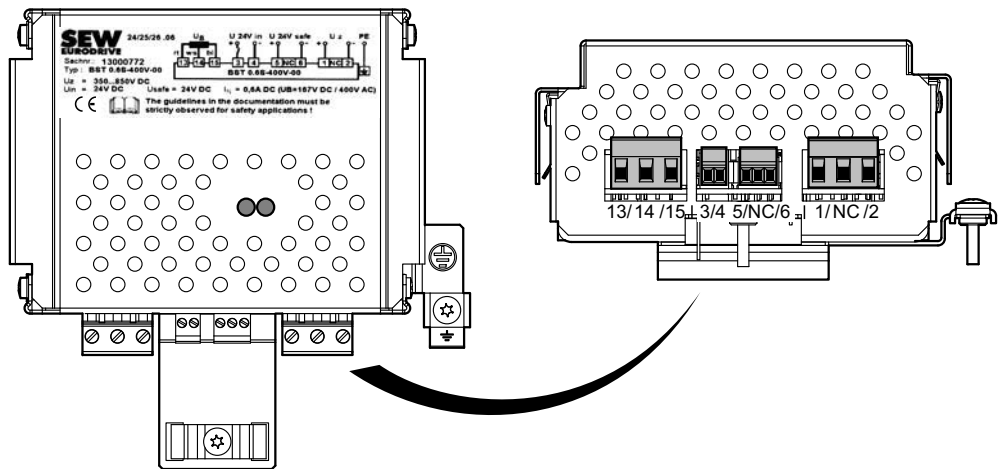

Terminal		Function
1	+U _Z	DC link voltage input
2	-U _Z	
5	SVI24	Safety-relevant control voltage V _{24 V safe} input
6	SOV24	Reference potential for safety-relevant control voltage V _{24 V safe}
3	DBI24	Functional control voltage V _{24 V in} input:
4	DGND	
13	RD	Brake output
14	WH	
15	BU	
⊕		Protective grounding

kVA		n
		f
i		
P		Hz

5 Technical Data of External Accessories

5.1 *DMP11B mounting panel option*

5.1.1 Part number

818 398 8

5.1.2 Description

DMP11B

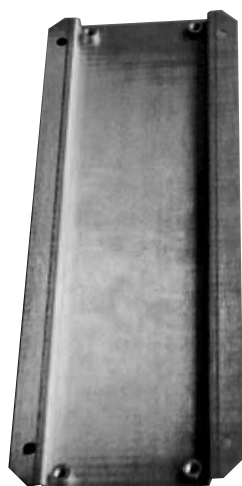

1454393867

If a MOVIDRIVE® MD_60A size 2 unit is to be replaced by MOVIDRIVE® MDX61B size 2S, the MDX61B size 2S can be fitted on the existing mounting plate with the DMP11B mounting panel. New retaining holes do not have to be drilled.

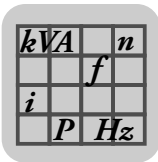

5.2 DLB11B touch guard option

5.2.1 Part number

823 111 7 (12 pieces included in the scope of delivery)

5.2.2 Description

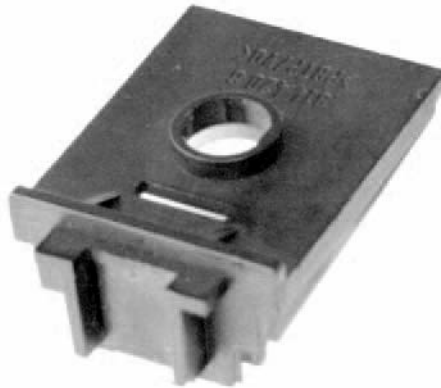

1454399115

Degree of protection IP20 can be achieved with touch guard DLB11B for the following units:

- MOVIDRIVE® MDX61B size 4 (AC 500 V units: MDX61B0370/0450; AC 230 V units: MDX61B0220/0300)
- MOVIDRIVE® MDX61B size 5 (AC 500 V units: MDX61B0550/0750)
- Regenerative power supply MOVIDRIVE® MDR60A size 4 (MDR600750-503-00)

kVA	n
	f
i	
P	Hz

5.3 DLB21B touch guard option (for size 7)

5.3.1 Part number

1 822 608 6

5.3.2 Description

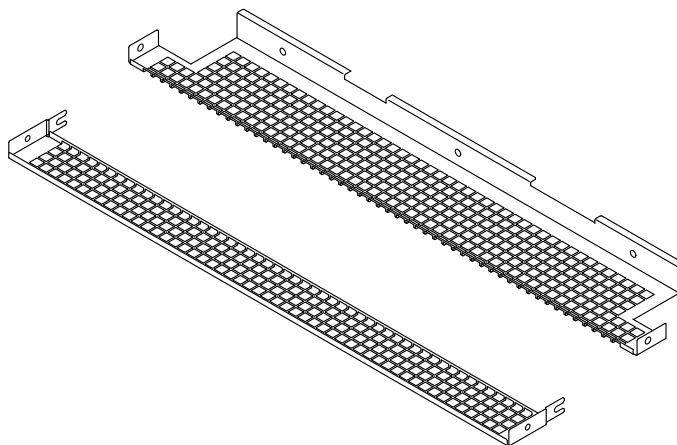

2422310283

You can use the DLB21B touch guard to achieve degree of protection IP20 for the following units:

- MOVIDRIVE® MDX61B size 7
(AC 500 V units: MDX61B1600/2000/2500)

Fixing material for the touch guard is included in the scope of delivery. The customer must adapt the touch guard to the individual cable routing (cutting the hole matrix for supply system and motor cables).

kVA		n
	f	
i		
P	Hz	

Technical Data of External Accessories

DLS11B mounting base option (for size 7)

5.4 DLS11B mounting base option (for size 7)

5.4.1 Part number

1 822 602 7

5.4.2 Description

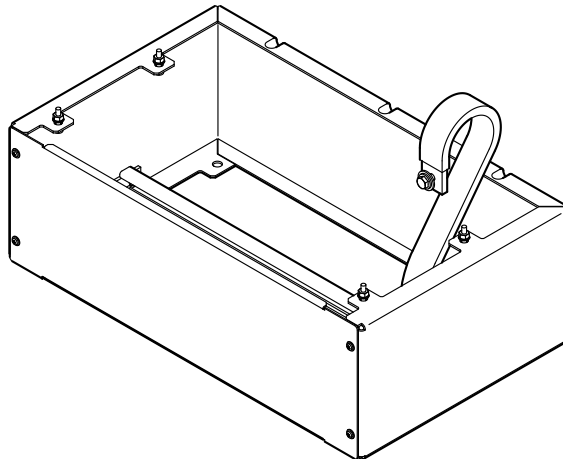

2422218507

The mounting base is designed specifically for installation of MOVIDRIVE® B size 7 (MDX61B1600/2000/2500) in the control cabinet. The base is equipped with an integrated cable clamping rail. It ensures sufficient space for connecting the supply system and motor cables. The front cover can be removed for installation work. Fixing material for mounting the inverter to the mounting base is included in the scope of delivery.

kVA	n
	f
i	
P	Hz

5.5 DLH11B wall bracket (for size 7)

5.5.1 Part number

1 822 610 8

5.5.2 Description

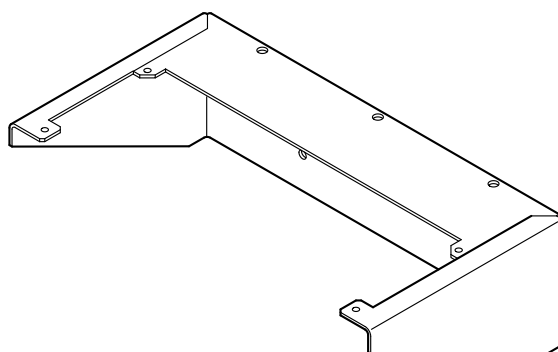

2422218507

The wall bracket is used for attaching MOVIDRIVE® B size 7 (MDX61B1600/2000/2500) to a wall. The fixing material for mounting the inverter to the wall bracket is included in the scope of delivery. The fixing material for mounting the bracket to the wall is not included in the scope of delivery.

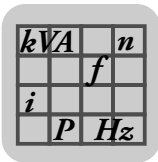

5.6 DLA11B connection kit option (for size 7)

5.6.1 Part number

1 822 312 5

5.6.2 Description



2422220427

Connection material for connecting supply system and motor cables with cross sections up to 240 mm² to the following units:

- MOVIDRIVE[®] MDX61B size 7
(AC 500 V units: MDX61B1600/2000/2500)

The connection kit includes the following material:

- 9 × bolts M12×30
- 9 × M12 nuts
- Lock washers
- Washers
- 3 × PE terminals for PE bus bar (up to 240 mm²)

kVA	n
	f
i	
P	Hz

5.7 DLK11B air duct option (for size 7)

5.7.1 Part number

1 822 603 5

5.7.2 Description

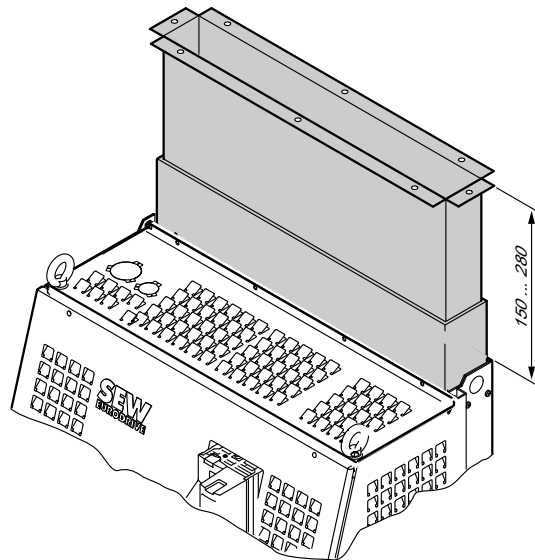

2076990731

Air duct for dissipating heat from MOVIDRIVE® B size 7 (MDX61B1600/2000/2500).

The air duct extends the integrated unit air duct of size 7 to the control cabinet roof to dissipate heat from the control cabinet. It improves the temperature management. A prerequisite is that air can be dissipated via the control cabinet roof (dust protection, etc.).

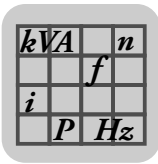

5.8 DLZ11B DC link coupling option (for size 7)

5.8.1 Part number

The DLZ11B DC link coupling is available in three different lengths:

Type	Part number
DLZ11B / 100 mm	1 823 193 4
DLZ11B / 200 mm	1 823 566 2
DLZ11B / 300 mm	1 823 567 0

5.8.2 Description

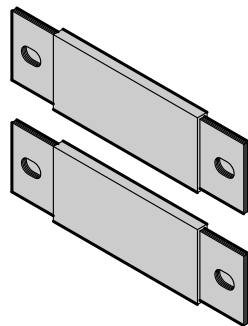

2422314891

DC link coupling for connecting 2 inverters side by side.

- MOVIDRIVE® MDX61B size 7
(AC 500 V units: MDX61B1600/2000/2500)

The DC link (+U_z; -U_z) of size 7 can be connected on the side as standard. The DLZ11B DC link coupling allows for two MOVIDRIVE® B size 7 inverters to be connected. Depending on the DC link coupling, the inverters must be installed at a distance of 100 mm, 200 mm, or 300 mm; the tolerance is about 4 mm. Two insulated bus bars and fixing material are included in the scope of delivery.

kVA		n
		f
i		
P		H_z

5.9 2Q DLZ12B DC link adapter option (for size 7)

5.9.1 Part number

1 822 729 5

5.9.2 Description

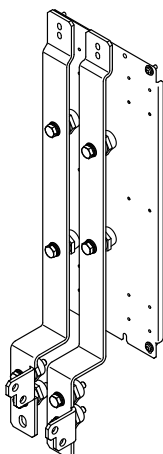

2422222347

DC link adapter for routing the DC link connection to the bottom of the unit. Only for size 7 (160 kW...250 kW).

For units:

- MDX61B1600-503-2-0T/L
- MDX61B2000-503-2-0T/L
- MDX61B2500-503-2-0T/L

The DC link (+U_z; -U_z) of size 7 can be connected on the side as standard. The 2Q DC link adapter provides a connection option for +U_z and -U_z at the bottom of the unit.

The DC link adapter should be used for DC link coupling with MOVIDRIVE® B sizes 0 to 6.

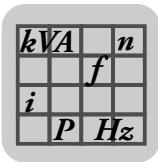

Technical Data of External Accessories

4Q DLZ14B DC link adapter option (for size 7)

5.10 4Q DLZ14B DC link adapter option (for size 7)

5.10.1 Part number

1 822 728 7

5.10.2 Description

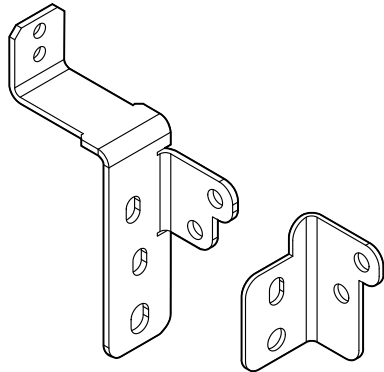

2435823499

DC link adapter for routing the DC link connection to the bottom of the unit. Only for size 7 (160 kW...250 kW).

For units:

- MDX61B1600-503-4-0T/L
- MDX61B2000-503-4-0T/L
- MDX61B2500-503-4-0T/L

The DC link (+U_z; -U_z) of size 7 can be connected on the side as standard. The 4Q DC link adapter provides a connection option for +U_z and -U_z at the bottom of the unit. The DC link adapter should be used for DC link coupling with MOVIDRIVE® B sizes 0 to 6.

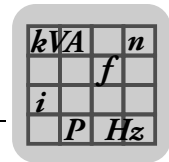

6 Technical Data of Braking Resistors, Chokes, and Filters

6.1 BW... braking resistor option / BW...-T / BW...-P

6.1.1 General information

- Braking resistors BW... / BW...-T and BW...-P match the technical features of the MOVIDRIVE® inverters.
- Take account of a power reduction of 4 % per 10 K from an ambient temperature of 40 °C. Do not exceed a maximum ambient temperature of 80 °C.

PTC resistor BW090-P52B

- Direct installation on MOVIDRIVE® MDX60B/61B size 0 (0005 ... 0014) (→ chapter "MOVIDRIVE® MDX60B dimension drawings")
- The MOVIDRIVE® units can be lined up even with mounted braking resistor BW090-P52B.
- The resistor protects itself (reversible) against regenerative overload by changing abruptly to high resistance and no longer consuming any more energy. The inverter then switches off and signals a brake chopper fault (F04).

Flat-type braking resistors

- Protection against contact (IP54)
- Internal thermal overload protection (non-replaceable fuse)
- Touch guard and mounting rail attachment available from SEW as accessories

Wire and grid resistors

- Perforated sheet cover (IP20) open to mounting surface
- The short-term load capacity of the wire and grid resistors is higher than in the flat-type braking resistors (→ MOVIDRIVE® MDX60B/61B system manual, chapter "Braking resistor selection")
- A temperature switch is integrated in the BW...-T braking resistor
- A thermal overcurrent relay is integrated in the BW...-P braking resistor

SEW-EURODRIVE recommends implementing additional protection against overload for the wire and grid resistors by using a bimetallic relay with trip characteristics of trip class 10 or 10A (in accordance with EN 60947-4-1). Set the trip current to the value I_F (→ following tables). Do not use electronic or electromagnetic fuses because these can be triggered even in case of short-term excess currents that are still within the tolerance range.

For braking resistors in the BW...-T / BW...-P series, you can connect the integrated temperature sensor / overcurrent relay using a 2-core, shielded cable as an alternative to a bimetallic relay. The cable entry for the BW...-T and BW...-P braking resistors can be run from the front or the back (→ dimension drawing for BW... / BW...-T / BW...-P braking resistors). Use filler plugs for tapped holes that are not connected.

The resistor surfaces reach high temperatures under load with P_N . Make sure that you select an installation site that will accommodate these high temperatures. As a rule, therefore, braking resistors are mounted on the control cabinet roof.

The performance data listed in the tables below show the load capacity of the braking resistors according to their cyclic duration factor (cyclic duration factor = cdf of the braking resistor in % in relation to a cycle duration ≤ 120 s).

kVA		n
	f	
i		
P	H_z	

Technical Data of Braking Resistors, Chokes, and Filters

BW... braking resistor option / BW...-T / BW...-P

6.1.2 UL and cUL approval

Type BW... braking resistors are UL and cUL approved in conjunction with MOVIDRIVE® B inverters. SEW-EURODRIVE will provide certification on request. The BW...-T and BW...-P braking resistors have cRUus approval independent of the MOVIDRIVE® inverters.

6.1.3 Parallel connection

Two braking resistors with the same value must be connected in parallel for some inverter/resistor combinations. In this case, the trip current must be set on the bimetallic relay to twice the value of I_F entered in the table. For the BW...-T BW...-P braking resistors, the temperature switch/overcurrent relay must be connected in series.

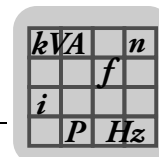

6.1.4 Assignment to AC 400/500 V units (...-5_3)

Braking resistor type BW...	BW090-P52B	BW100-005	BW100-006	BW072-003	BW072-005	BW168	BW268
Part number	824 563 0	826 269 1	821 701 7	826 058 3	826 060 5	820 604 X	820 715 1
Braking resistor type BW...-T			BW100-006-T			BW168-T	BW268-T
Part number			1820 419 8			1820 133 4	1820 417 1
Cont. braking power (= 100% cdf)	0.10 kW	0.45 kW	0.6 kW	0.23 kW	0.45 kW	0.8 kW	1.2 kW
Load capacity 50 % cdf ¹⁾	0.15 kW	0.60 kW	1.1 kW	0.31 kW	0.60 kW	1.4 kW	2.2 kW
at 25 % cdf	0.2 kW	0.83 kW	1.9 kW	0.42 kW	0.83 kW	2.6 kW	3.8 kW
12 % cdf	0.4 kW	1.11 kW	3.6 kW	0.58 kW	1.11 kW	4.8 kW	7.2 kW
6 % cdf	0.7 kW	2.00 kW	5.7 kW	1.00 kW	2.00 kW	7.6 kW	11 kW
Observe the regenerative power limit of the inverter! (= 150 % of the recommended motor power → technical data)							
Resistance value R _{BW}	90 Ω ±35 %	100 Ω ±10%		72 Ω ±10%		68 Ω ±10%	
Trip current (of F16) I _F	-	0.8 A	2.4 A	0.6 A	1 A	3.4 A	4.2 A
Design	PTC	Flat design	Wire resistor on ceramic core	Flat design		Wire resistor on ceramic core	
Connections / Tightening torque	Cable	Cable	Ceramic terminals 2.5 mm ² (AWG13) 0.5 Nm	Cable		Ceramic terminals 2.5 mm ² (AWG13) 0.5 Nm	
Degree of protection	IP20	IP54	IP20 (when installed)	IP54		IP20 (when installed)	
Ambient temperature θ _U	-20 ... +40 °C						
Type of cooling	KS = self-cooling						
For MOVIDRIVE® (recommended)	0005 ... 0014	0005 ... 0022	0015 ... 0040	0005 ... 0014		0005 ... 0040	0015 ... 0040

1) cdf = Cyclic duration factor of the braking resistor in relation to a cycle duration T_D ≤ 120 s.

Braking resistor type BW...	BW147	BW247	BW347	BW039-012		
Part number	820 713 5	820 714 3	820 798 4	821 689 4		
Braking resistor type BW...-T	BW147-T	BW247-T	BW347-T	BW039-012-T	BW039-026-T	BW039-050-T
Part number	1820 134 2	1820 084 2	1820 135 0	1820 136 9	1820 415 5	1820 137 7
Cont. braking power (= 100% cdf)	1.2 kW	2.0 kW	4.0 kW	1.2 kW	2.6 kW	5.0 kW
Load capacity 50 % cdf ¹⁾	2.2 kW	3.6 kW	7.2 kW	2.1 kW	4.7 kW	8.5 kW
at 25 % cdf	3.8 kW	6.4 kW	12.8 kW	3.8 kW	8.3 kW	15.0 kW
12 % cdf	7.2 kW	12 kW	20 kW ²⁾	7.2 kW	15.6 kW	24.0 kW
6 % cdf	11 kW	19 kW	20 kW	11.4 kW	24.0 kW	24.0 kW
Observe the regenerative power limit of the inverter! (= 150 % of the recommended motor power → technical data)						
Resistance value R _{BW}	47 Ω ±10%			39 Ω ±10%		
Trip current (of F16) I _F	5 A	6.5 A	9.2 A	5.5 A	8.1 A	11.3 A
Design	Wire resistor on ceramic core					Grid resistor
Connections / Tightening torque	Ceramic terminals 2.5 mm ² (AWG13) / 0.5 Nm BW347-T: Ceramic terminals 10 mm ² (AWG18) / 1.6 Nm					M8 stud / 6 Nm
Degree of protection	IP20 (when installed)					
Ambient temperature θ _U	-20 ... +40 °C					
Type of cooling	KS = self-cooling					
For MOVIDRIVE® (recommended)	0055/0075			0110		

1) cdf = Cyclic duration factor of the braking resistor in relation to a cycle duration T_D ≤ 120 s.

2) Physical power limit due to DC link voltage and resistance value.

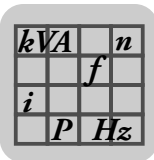

Technical Data of Braking Resistors, Chokes, and Filters

BW... braking resistor option / BW...-T / BW...-P

Braking resistor type BW...	BW018-015			
Part number	821 684 3			
Braking resistor type BW...-T/-P	BW018-015-P	BW018-035-T	BW018-075-T	BW915-T
Part number	1820 416 3	1820 138 5	1820 139 3	1820 413 9
Cont. braking power (= 100% cdf)	1.5 kW	3.5 kW	7.5 kW	16 kW
Load capacity 50 % cdf ¹⁾	2.5 kW	5.9 kW	12.7 kW	27.2 kW
at 25 % cdf	4.5 kW	10.5 kW	22.5 kW	48 kW
12 % cdf	6.7 kW	15.7 kW	33.7 kW	62.7 kW
6 % cdf	11.4 kW	26.6 kW	52.2 kW ²⁾	62.7 kW
Observe the regenerative power limit of the inverter! (= 150 % of the recommended motor power → technical data)				
Resistance value R_{BW}	18 Ω \pm 10%			15 Ω \pm 10%
Trip current (of F16) I_F	9.1 A	13.9 A	20.4 A	32.6 A
Design	Wire resistor on ceramic core	Grid resistor		
Connections / Tightening torque	BW018-015: Ceramic terminals 2.5 mm ² (AWG13) / 0.5 Nm BW018-015-P: Terminal 2.5 mm ² (AWG13) / 1 Nm	Bolt M8 / 6 Nm		
Degree of protection	IP20 (when installed)			
Ambient temperature ϑ_U	-20 ... +40 °C			
Type of cooling	KS = self-cooling			
For MOVIDRIVE® (recommended)	0150/0220 and 2 × parallel with 0370/0450 ³⁾			0220

- 1) cdf = Cyclic duration factor of the braking resistor in relation to a cycle duration $T_D \leq 120$ s.
- 2) Physical power limit due to DC link voltage and resistance value.
- 3) When connected in parallel, the load capacity and trip current are doubled.

Braking resistor type BW...-	BW012-025		
Part number	821 680 0		
Braking resistor type BW...-T/-P	BW012-025-P	BW012-050T	BW012-100-T
Part number	1820 414 7	1820 140 7	1820 141 5
Cont. braking power (= 100% cdf)	2.5 kW	5.0 kW	10 kW
Load capacity 50 % cdf ¹⁾	4.2 kW	8.5 kW	17 kW
at 25 % cdf	7.5 kW	15.0 kW	30 kW
12 % cdf	11.2 kW	22.5 kW	45 kW
6 % cdf	19.0 kW	38.0 kW	76 kW
Observe the regenerative power limit of the inverter! (= 150 % of the recommended motor power → technical data)			
Resistance value R_{BW}	12 Ω \pm 10%		
Trip current (of F16) I_F	14.4 A	20.4 A	28.8 A
Design	Grid resistor		
Connections / Tightening torque	Ceramic terminals 2.5 mm ² (AWG13) / 0.5 Nm BW012-025-P: Terminals 4 mm ² (AWG12) / 1 Nm		
Degree of protection	IP20 (when installed)		
Ambient temperature ϑ_U	-20 ... +40 °C		
Type of cooling	KS = self-cooling		
For MOVIDRIVE® (recommended)	0300		

- 1) cdf = Cyclic duration factor of the braking resistor in relation to a cycle duration $T_D \leq 120$ s.

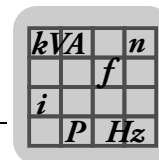

Braking resistor type BW...-T/-P	BW106-T	BW206-T	BW1.4-170-T	BW003-420-T
Part number	1820 083 4	1820 412 0	1330 152 7	1330 124 5
Cont. braking power (= 100% cdf)	13.5 kW	18 kW	17 kW	42 kW
Load capacity 50 % cdf ¹⁾	23 kW	30.6 kW	30.6 kW	75.6 kW
at 25 % cdf	40 kW	54 kW	51 kW	126 kW
12 % cdf	61 kW	81 kW	85 kW	210 kW
6 % cdf	102 kW	136.8 kW	270 kW	360 kW
Resistance value R_{BW}	6 Ω \pm 10%		1.4 Ω \pm 10%	2.5 Ω \pm 10%
Trip current (of F16) I_F	47.4 A	54.7 A	110 A	129 A
Design	Grid resistor			
Connections / Tightening torque	Bolt M8 / 6 Nm		Bolt M12 / 15.5 Nm	
Degree of protection	IP20 (when installed)			
Ambient temperature ϑ_U	-20 ... +40 °C			
Type of cooling	KS = self-cooling			
For MOVIDRIVE® (recommended)	0370...0750 and 2 × parallel with 0900/1100/1320 ²⁾		1600/2000/2500	

- 1) cdf = Cyclic duration factor of the braking resistor in relation to a cycle duration $T_D \leq 120$ s.
- 2) When connected in parallel, the load capacity and trip current are doubled.

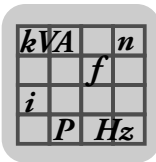

6.1.5 Assignment to AC 230 V units (...-2_3)

Braking resistor type BW...	BW039-003	BW039-006	BW039-012		BW027-006	BW027-012		
Part number	821 687 8	821 688 6	821 689 4		822 422 6	822 423 4		
Braking resistor type BW...-T			BW039-012-T	BW039-026-T			BW018-015-P	BW018-035-T
Part number			1820 136 9	1820 415 5			1820 416 3	1820 138 5
Cont. braking power (= 100% cdf)	0.3 kW	0.6 kW	1.2 kW	2.6 kW	0.6 kW	1.2 kW	1.5 kW	3.5 kW
Load capacity 50 % cdf ¹⁾	0.5 kW	1.1 kW	2.1 kW	4.6 kW	1.1 kW	2.1 kW	2.5 kW	5.9 kW
at 25 % cdf	1.0 kW	1.9 kW	3.8 kW	6.0 kW	1.9 kW	3.8 kW	4.5 kW	10.5 kW
12 % cdf	1.8 kW	3.6 kW	6.0 kW ²⁾	6.0 kW	3.6 kW	7.2 kW	6.7 kW	13.0 kW
6 % cdf	2.8 kW	5.7 kW	6.0 kW	6.0 kW	5.7 kW	8.7 kW	11.4 kW	13.0 kW
Observe the regenerative power limit of the inverter! (= 150 % of the recommended motor power → technical data)								
Resistance value R_{BW}	39 Ω ±10%				27 Ω ±10%		18 Ω ±10%	
Trip current (of F16) I_F	2.7 A	3.9 A	5.5 A	8.1 A	4.7 A	6.6 A	9.1 A	13.9 A
Design	Wire resistor					Grid resistor		
Connections / Tightening torque	Ceramic terminals 2.5 mm ² (AWG12) / 0.5 Nm						M8 stud / 6 Nm	
Degree of protection	IP20 (when installed)							
Ambient temperature ϑ_U	-20 ... +40 °C							
Type of cooling	KS = self-cooling							
For MOVIDRIVE® (recommended)	0015/0022				0015...0037		2 × parallel with 0110 ³⁾	

- 1) cdf = Cyclic duration factor of the braking resistor in relation to a cycle duration of $T_D \leq 120$ s.
- 2) Physical power limit due to DC link voltage and resistance value.
- 3) When connected in parallel, the load capacity and trip current are doubled.

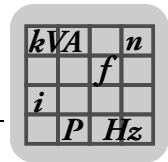

Braking resistor type BW...-T/-P	BW018-075-T	BW915-T	BW012-025-P	BW012-050-T	BW012-100-T	BW106-T	BW206-T
Part number	1820 139 3	1820 413 9	1820 414 7	1820 140 7	1820141 5	1820 083 4	1820 412 0
Cont. braking power (= 100% cdf)	7.5 kW	15.6 kW	2.5 kW	5.0 kW	10 kW	13.5 kW	18 kW
Load capacity 50 % cdf ¹⁾	12.7 kW	15.6 kW	4.2 kW	8.5 kW	17 kW	23 kW	30.6 kW
At 25 % cdf	13.0 kW	15.6 kW	7.5 kW	15.0 kW	19.6 kW	39.2 kW	39.2 kW
12 % cdf	13.0 kW ²⁾	15.6 kW	11.2 kW	19.6 kW	19.6 kW	39.2 kW	39.2 kW
6 % cdf	13.0 kW	15.6 kW	19.0 kW	19.6 kW	19.6 kW	39.2 kW	39.2 kW
Observe the regenerative power limit of the inverter! (= 150 % of the recommended motor power → technical data)							
Resistance value R_{BW}	18 Ω ±10%	15 Ω ±10 %	12 Ω ±10%			6 Ω ±10%	
Trip current (of F16) I_F	20.4 A	32.6 A	14.4 A	20.4 A	28.8 A	47.4 A	54.7 A
Design	Grid resistor						
Connections / Tightening torque	M8 stud / 6 Nm						
Degree of protection	IP20 (when installed)						
Ambient temperature ϑ_U	-20 ... +40 °C						
Type of cooling	KS = self-cooling						
For MOVIDRIVE® (recommended)	2 × parallel with 0110		0055/0075			0150 and 2 × parallel with 0220/0300 ³⁾	

- 1) cdf = Cyclic duration factor of the braking resistor in relation to a cycle duration $T_D \leq 120$ s.
- 2) Physical power limit due to DC link voltage and resistance value.
- 3) When connected in parallel, the load capacity and trip current are doubled.

6.1.6 Technical data of BW...-T / BW...-P braking resistors

BW...-T / BW...-P	
Connection cross section for signal contact	1 x 2.5 mm ²
Switching capability of the thermostat's signal contact	<ul style="list-style-type: none"> • DC 2 A / DC 24 V (DC11) • AC 2 A / AC 230V (AC11)
Switch contact (NC)	according to EN 61800-5-1

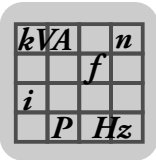

6.1.7 Dimension drawing of BW.. braking resistors / BW...-T / BW...-P

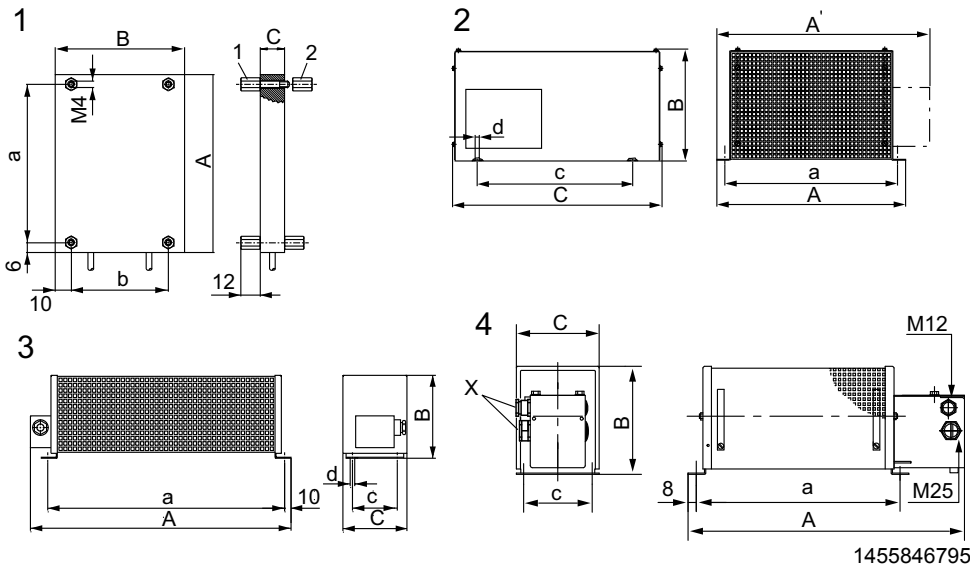

BW...:

- 1 = Flat design
The connecting lead is 500 mm (19.7 in) long. The scope of delivery includes four M4 stud bolts each of type 1 and 2.
- 2 = Grid resistor
- 3 = Wire resistor
- 4 = Wire resistor with temperature switch (-T/-P)

Cable entry (X) is possible from both sides.

1455846795

BW... type	Mounting position	Main dimensions mm (in)			Fastening parts mm (in)			Cable gland	Mass kg (lb)
		A/A'	B	C	a	b/c	d		
BW...-T / BW...-P									
BW106-T	2	795 (31.3)	270 (10.6)	490 (19.3)	770(30.3)	380 (15)	10.5 (0.41)	-	32 (71)
BW206-T	2	995 (39.2)	270 (10.6)	490 (19.3)	970 (38.2)	380 (15)	10.5 (0.41)	-	40 (88)
BW012-025	2	295 (11.6)	260 (10.2)	490 (19.3)	270 (10.6)	380 (15)	10.5 (0.41)	M12 + M25	8.0 (18)
BW012-025-P	2	295/355 (11.6)/(14)	260 (10.2)	490 (19.3)	270 (10.6)	380 (15)	10.5 (0.41)	M12 + M25	8.0 (18)
BW012-050-T	2	395 (15.6)	260 (10.2)	490 (19.3)	370 (14.6)	380 (15)	10.5 (0.41)	-	12 (26)
BW012-100-T	2	595 (23.4)	270 (10.6)	490 (19.3)	570 (22.4)	380 (15)	10.5 (0.41)	-	21 (46)
BW915-T	2	795 (31.3)	270 (10.6)	490 (19.3)	770 (30.3)	380 (15)	10.5 (0.41)	-	30 (66)
BW018-015	3	620 (24.4)	120 (4.72)	92 (3.6)	544 (21.4)	64 (2.5)	6.5 (0.26)	PG11	4.0 (8.8)
BW018-015-P	4	649 (25.6)	120 (4.72)	185 (7.28)	530 (20.9)	150 (5.91)	6.5 (0.26)	M12 + M25	5.8 (13)
BW018-035-T	2	295 (11.6)	270 (10.6)	490 (19.3)	270 (10.6)	380 (15)	10.5 (0.41)	-	9.0 (20)
BW018-075-T	2	595 (23.4)	270 (10.6)	490 (19.3)	570 (22.4)	380 (15)	10.5 (0.41)	-	18.5 (40.8)
BW027-006	3	486 (19.1)	120 (4.72)	92 (3.6)	430 (16.9)	64 (2.5)	6.5 (0.26)	PG11	2.2 (4.9)
BW027-012	3	486 (19.1)	120 (4.72)	185 (7.28)	426 (16.8)	150 (5.91)	6.5 (0.26)	PG11	4.3 (9.5)
BW039-003	3	286 (11.3)	120 (4.72)	92 (3.6)	230 (9.06)	64 (2.5)	6.5 (0.26)	PG11	1.5 (3.3)
BW039-006	3	486 (19.1)	120 (4.72)	92 (3.6)	430 (16.9)	64 (2.5)	6.5 (0.26)	PG11	2.2 (4.9)
BW039-012	3	486 (19.1)	120 (4.72)	185 (7.28)	426 (16.8)	150 (5.91)	6.5 (0.26)	PG11	4.3 (9.5)
BW039-012-T	4	549 (21.6)	120 (4.72)	185 (7.28)	426 (16.8)	150 (5.91)	6.5 (0.26)	M12 + M25	4.9 (11)
BW039-026-T	4	649 (25.6)	120 (4.72)	275 (10.8)	530 (20.9)	240 (9.45)	6.5 (0.26)	M12 + M25	7.5 (17)
BW039-050-T	2	395 (15.6)	260 (10.2)	490 (19.3)	370 (14.6)	380 (15)	10.5 (0.41)	-	12 (26)
BW147	3	465 (18.3)	120 (4.72)	185 (7.28)	426 (16.8)	150 (5.91)	6.5 (0.26)	PG13.5	4.3 (9.5)
BW147-T	4	549 (21.6)	120 (4.72)	185 (7.28)	426 (16.8)	150 (5.91)	6.5 (0.26)	M12 + M25	4.9 (11)
BW247	3	665 (26.2)	120 (4.72)	185 (7.28)	626 (24.6)	150 (5.91)	6.5 (0.26)	PG13.5	6.1 (13)
BW247-T	4	749 (29.5)	120 (4.72)	185 (7.28)	626 (24.6)	150 (5.91)	6.5 (0.26)	M12 + M25	9.2 (20)
BW347	3	670 (26.4)	145 (5.71)	340 (13.4)	630 (24.8)	300 (11.8)	6.5 (0.26)	PG13.5	13.2 (29.1)
BW347-T	4	749 (29.5)	210 (8.27)	185 (7.28)	630 (24.8)	150 (5.91)	6.5 (0.26)	M12 + M25	12.4 (27.3)
BW168	3	365 (14.4)	120 (4.72)	185 (7.28)	326 (12.8)	150 (5.91)	6.5 (0.26)	PG13.5	3.5 (7.7)
BW168-T	4	449 (17.7)	120 (4.72)	185 (7.28)	326 (12.8)	150 (5.91)	6.5 (0.26)	M12 + M25	3.6 (7.9)
BW268	3	465 (18.3)	120 (4.72)	185 (7.28)	426 (16.8)	150 (5.91)	6.5 (0.26)	PG13.5	4.3 (9.5)
BW268-T	4	549 (21.6)	120 (4.72)	185 (7.28)	426 (16.8)	150 (5.91)	6.5 (0.26)	M12 + M25	4.9 (11)
BW072-003	1	110 (4.33)	80 (3.1)	15 (0.59)	98 (3.9)	60 (2.4)	-	-	0.3 (0.7)
BW072-005	1	216 (8.5)	80 (3.1)	15 (0.59)	204 (8.03)	60 (2.4)	-	-	0.6 (1)
BW100-005	1	216 (8.5)	80 (3.1)	15 (0.59)	204 (8.03)	60 (2.4)	-	-	0.6 (1)
BW100-006	4	486 (19.1)	120 (4.72)	92 (3.6)	430 (16.9)	64 (2.5)	6.5 (0.26)	PG11	2.2 (4.9)

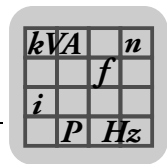

BW... type BW...-T/ BW...-P	Mounting position	Main dimensions mm (in)			Fastening parts mm (in)			Cable gland	Mass kg (lb)
		A/A'	B	C	a	b/c	d		
BW100-006-T	4	549 (21.6)	120 (4.72)	92 (3.6)	430 (16.9)	80 (3.1)	6.5 (0.26)	M12 + M25	3.0 (6.6)
BW206-120-T	2	595 (23.4)	270 (10.6)	490 (19.3)	570 (22.4)	380 (15.0)	10.5 (0.41)	2×2×M8	22.0

6.1.8 Dimension drawings of BW1.4-170 and BW003-420-T braking resistors

The following figure shows the dimensions of the braking resistors BW1.4-170 and BW003-420-T.

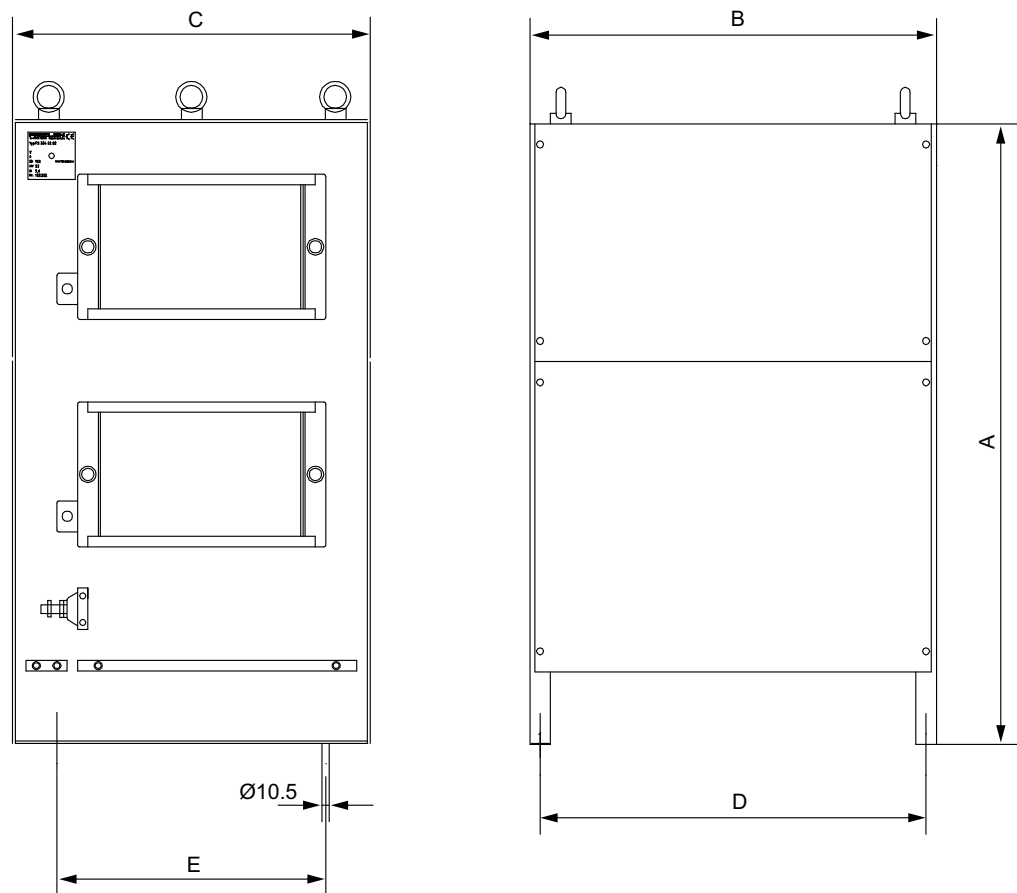

2649275275

BW... type BW...-T/ BW...-P	Main dimensions mm (in)					Terminal stud / tightening torque	Mass kg (lb)
	A	B	C	D	E		
BW1.4-170	460 (18.1)	795 (31.3)	490 (19.3)	770 (30.3)	380 (15.0)	M12 / 15.5 Nm	51 (112)
BW003-420-T	710 (28.0)	995 (39.2)	490 (19.3)	970 (38.2)	380 (15.0)	M12 / 15.5 Nm	93 (205)

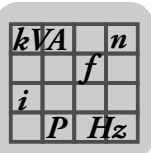
6.1.9 BS... touch guard

A BS.. touch guard is available for braking resistors in flat design.

Touch guard	BS003	BS005
Part number	813 151 1	813 152 X
for braking resistor	BW027-003 BW072-003	BW027-005 BW072-005 BW100-005

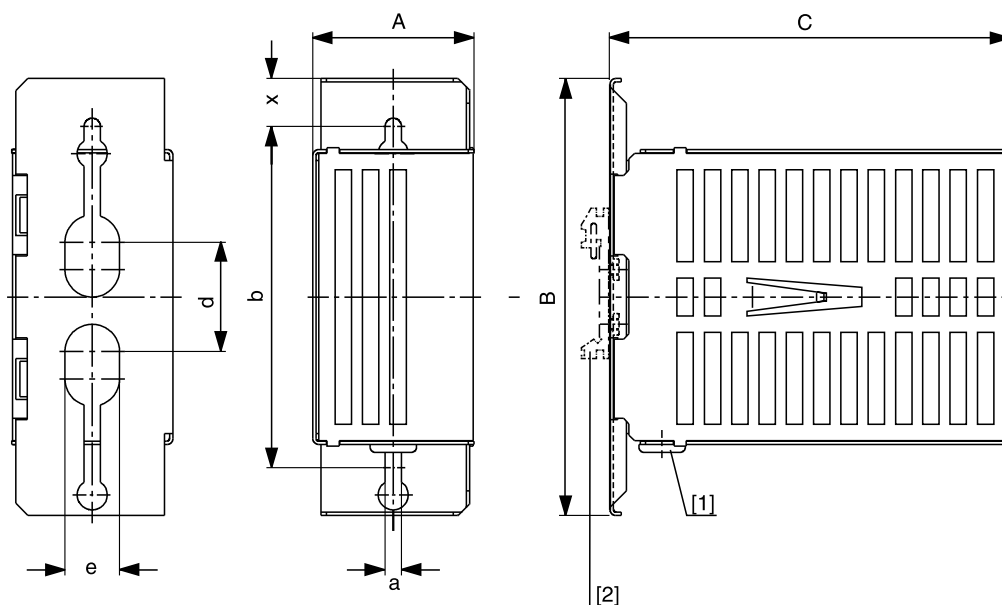
6.1.10 Dimension drawing of BS...

1455849867

- [1] Grommet
[2] Support rail mounting

Type	Main dimensions mm (in)			Mounting dimensions mm (in)					Weight kg (lb)
	A	B	C	b	d	e	a	x	
BS-003	60 (2.4)	160 (6.3)	146 (5.75)	125 (4.92)	40 (1.6)	20 (0.79)	6 (0.2)	17.5 (0.69)	0.35 (0.77)
BS-005	60 (2.4)	160 (6.3)	252 (9.92)	125 (4.92)	4 (1.6)	20 (0.79)	6 (0.2)	17.5 (0.69)	0.5 (1)

Support rail installation

A mounting rail attachment HS001 is available from SEW-EURODRIVE, part number 822 194 4, for mounting the touch guard on a mounting rail.

kVA	n
	f
i	
P	H_z

6.1.11 DKB11A heat sink for braking resistors in flatpack design

Part number 814 345 5

Description The DKB11A heat sink for braking resistors in flat design provides a space-saving means for mounting the braking resistors (BW072-005, BW100-005) beneath MOVIDRIVE® size 1 units (400/500 V units: 0015...0040; 230 V units: 0015...0037). The resistor is inserted into the heat sink and attached using the supplied screws (M4 × 20).

Dimension drawing

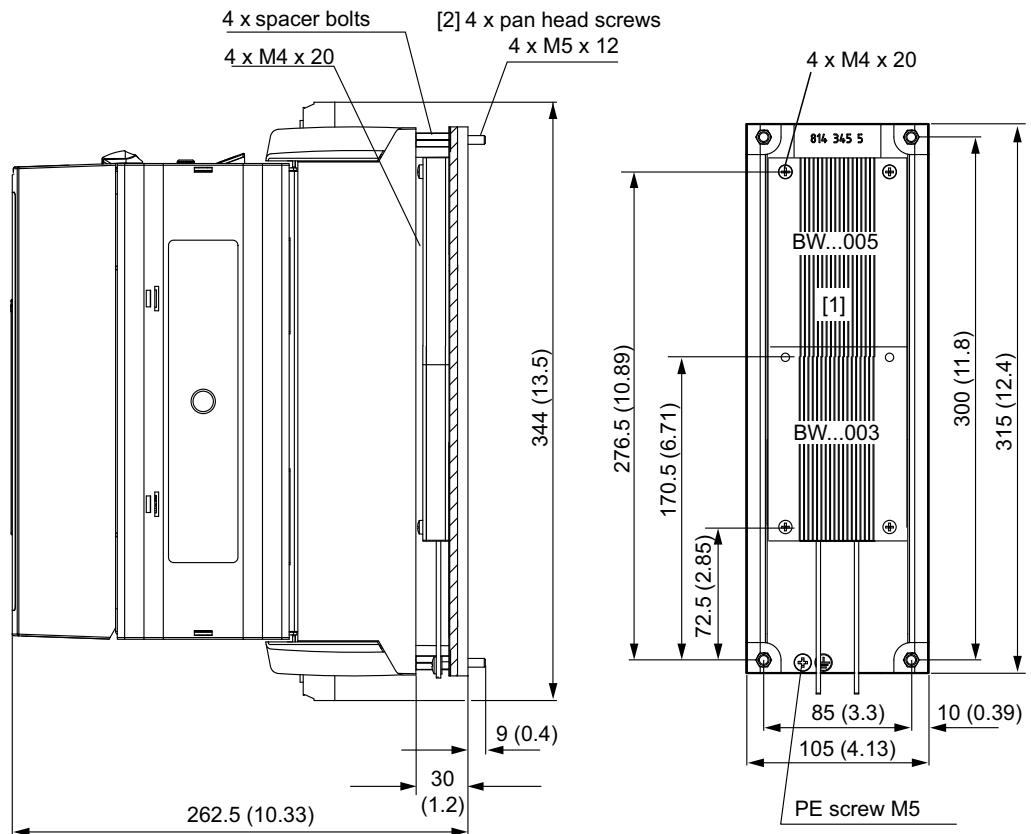

1455852939

All dimensions in mm (in)

- [1] Mounting surface for the braking resistor
- [2] You need 4 × M5 × 12 screws to mount the unit on the heat sink. These screws are not included in the scope of delivery.

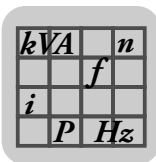

6.2 ND.. line choke option

- To increase overvoltage protection.
- To limit the charging current when several inverters are connected together in parallel on the input end with shared line contactors (nominal current of line choke = total of inverter currents).
- ND.. line filters have cRUus approval independent of the MOVIDRIVE® inverters.

Line choke type	ND020-013	ND030-023 ¹⁾	ND045-013	ND085-013	ND150-013	ND200-0033	ND300-0053
Part number	826 012 5	827 151 8	826 013 3	826 014 1	825 548 2	826 579 8	827 721 4
Rated line voltage V_{line} (according to EN 50160)	3 × AC 380 V - 500 V, 50/60 Hz						
Nominal current ²⁾ I_N	AC 20 A	AC 30 A	AC 45 A	AC 85 A	AC 150 A	AC 200 A	AC 300 A
Power loss at I_N P_V	10 W	30 W	15 W	25 W	65 W	100 W	280 W
Inductance L_N	0.1 mH	0.2 mH	0.1 mH	0.1 mH	0.1 mH	0.03 mH	0.05 mH
Ambient temperature ϑ_U	-25 ... +45 °C						
Degree of protection	IP00 (EN 60529)						
Connections	Terminal strips 4 mm ² (AWG12)	Terminal strips 2.5 mm ² ... 10 mm ² (AWG13 ... AWG8)	Terminal strips 10 mm ² (AWG8)	Terminal strips 35 mm ² (AWG2)	M10 stud PE: M8 stud		M12 stud PE: 2 × M10
Tightening torque	0.6 ... 0.8 Nm	Max. 2.5 Nm		3.2 ... 3.7 Nm	M10 stud: 10 Nm PE: 6 Nm		M12 stud: 15.5 Nm PE: 10 Nm
Assignment to AC 400/500 V units (MDX60/61B...-5_3)							
Rated operation (100 %)	0005...0075	0110...0220		0300...0450 and MDR60A0370	0550/0750	MDR60A 0750	0900...1320
Increased power (125 %)	0005...0075	0110/0150		0220...0370	0450...0750		
Assignment to AC 230 V units (MDX61B...-2_3)							
Rated operation (100 %)	0015...0055	-	0075/0110	0150/0220	0300	-	-
Increased power (125 %)	0015...0037	-	0055/0075	0110/0150	0220/0300	-	-

- 1) Use ND030-023 for DC link connection without regenerative power supply unit in connection type A or B (→ system manual MOVIDRIVE® MDR60A regenerative power supply)
- 2) If more than one MOVIDRIVE® unit is connected to a line choke, the total value of the rated currents of the connected units must not exceed the nominal current of the line choke.

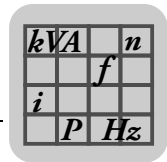

6.2.1 ND.. dimension drawings

Dimension drawing for line chokes ND020.. / ND030.. / ND045.. / ND085..

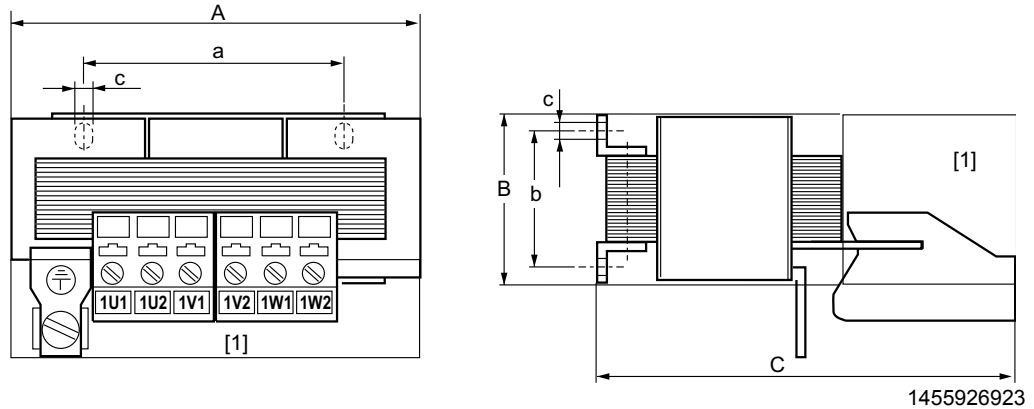

[1] Space for installation terminals
 Any mounting position
 Input: 1U1, 1V1, 1W1
 Output: 1U2, 1V2, 1W2

Dimension drawing for line chokes ND150.. / ND200.. / ND300..

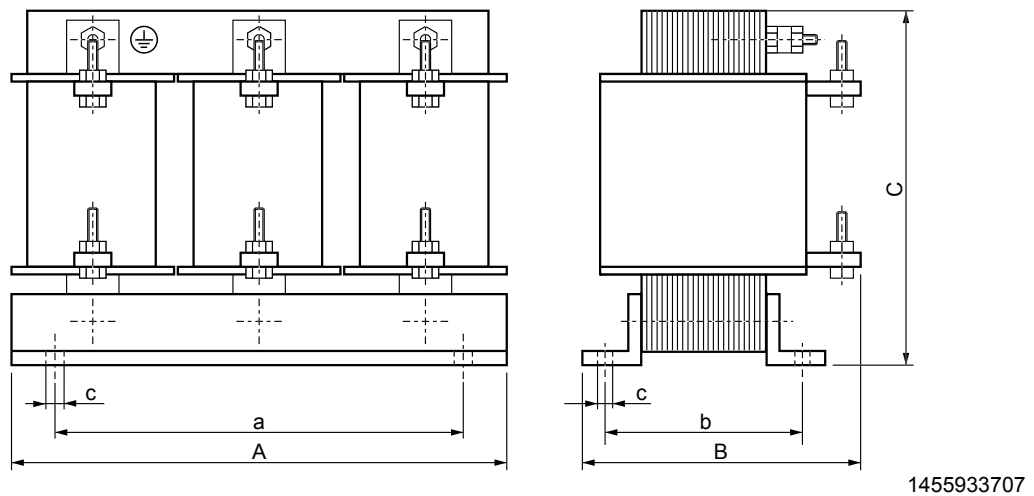

Line choke type	Main dimensions mm (in)			Mounting dimensions mm (in)		Hole dimension mm (in)	Mass kg (lb)
	A	B	C	a	b		
ND020-013	85 (3.3)	60 (2.4)	120 (4.72)	50 (2)	31 - 42 (1.2 - 1.7)	5 - 10 (0.2 - 0.39)	0.5 (1)
ND030-023 ND045-013	125 (4.92)	95 (3.7)	170 (6.69)	84 (3.3)	55-75 (2.2 - 3)	6 (0.24)	2.5 (5.5)
ND085-013	185 (7.28)	115 (4.53)	235 (9.25)	136 (5.35)	56 - 88 (2.2 - 3.5)	7 (0.28)	8 (18)
ND150-013	255 (10)	140 (5.51)	230 (9.06)	170 (6.69)	77 (3)	8 (0.31)	17 (37)
ND200-0033	250 (9.84)	160 (6.3)	230 (9.06)	180 (7.09)	98 (3.9)	8 (0.31)	15 (33)
ND300-0053	300 (11.8)	190 (7.48)	295 (11.6)	255 (10)	145 (5.71)	11 (0.43)	35 (77)

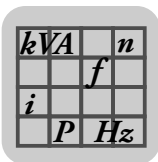

6.3 NF...-... line filter option

- To suppress interference emission on the line side of inverters.
- Do not switch between the NF... line filter and MOVIDRIVE®.
- NF.. line filters have cRUus approval independent of the MOVIDRIVE® inverters.

Line filter type	NF009-503	NF014-503	NF018-503	NF035-503	NF048-503
Part number	827 412 6	827 116 X	827 413 4	827 128 3	827 117 8
Rated line voltage V_{line} (according to EN 50160)	3 × AC 380 V - 500 V, 50/60 Hz				
Nominal current I_N	AC 9 A	AC 14 A	AC 18 A	AC 35 A	AC 48 A
Power loss at I_N P_V	6 W	9 W	12 W	15 W	22 W
Earth-leakage current at V_N	< 25 mA	< 25 mA	< 25 mA	< 25 mA	< 40 mA
Ambient temperature ϑ_U	-25 ... +40 °C				
Degree of protection	IP20 (EN 60529)				
Connections L1-L3/L1'-L3'	4 mm ² (AWG 10)		10 mm ² (AWG 8)	10 mm ² (AWG 8)	
Tightening torque L1-L3/L1'-L3'	0.8 Nm		1.8 Nm	1.8 Nm	
Connection PE	M5 stud		M5 stud	M6 stud	
Tightening torque PE	3.4 Nm		3.4 Nm	5.5 Nm	
Assignment to AC 400/500 V units (MDX60/61B...-5_3)					
Rated operation (100 %)	0005...0040	0055/0075	-	0110/0150	0220
Increased power (125 %)	0005...0030	0040/0055	0075	0110	0150
Assignment to AC 230 V units (MDX61B...-2_3)					
Rated operation (100 %)	0015/0022	0037	-	0055/0075	0110
Increased power (125 %)	0015	0022	0037	0055/0075	-

Line filter type	NF063-503	NF085-503	NF115-503	NF150-503	NF210-503
Part number	827 414 2	827 415 0	827 416 9	827 417 7	827 418 5
Rated line voltage V_{line} (according to EN 50160)	3 × AC 380 V - 500 V, 50/60 Hz				
Nominal current I_N	AC 63 A	AC 85 A	AC 115 A	AC 150 A	AC 210 A
Power loss at I_N P_V	30 W	35 W	60 W	90 W	150 W
Earth-leakage current at V_N	< 30 mA	< 30 mA	< 30 mA	< 30 mA	< 40 mA
Ambient temperature ϑ_U	-25 ... +40 °C				
Degree of protection	IP20 (EN 60529)				
Connections L1-L3/L1'-L3'	16 mm ² (AWG 6)	35 mm ² (AWG 2)	50 mm ² (AWG1/0)	50 mm ² (AWG1/0)	95 mm ² (AWG4/0)
Tightening torque L1-L3/L1'-L3'	3 Nm	3.7 Nm	3.7 Nm	3.7 Nm	20 Nm
Connection PE	M6	M8	M10	M10	M10
Tightening torque PE	5.5 Nm	12.8 Nm	23.8 Nm	23.8 Nm	23.8 Nm
Assignment to AC 400/500 V units (MDX60/61B...-5_3)					
Rated operation (100 %)	0300	0370/0450	0550	0750	0900/1100
Increased power (125 %)	0220	0300/0370	0450	0550/0750	0900
Assignment to AC 230 V units (MDX61B...-2_3)					
Rated operation (100 %)	0150	0220	0300	-	-
Increased power (125 %)	0110/0150	-	0220/0300	-	-

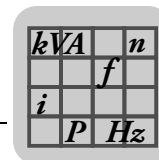

Line filter type	NF300-503	NF600-503
Part number	827 419 3	1 796 338 9
Rated line voltage V_{line} (according to EN 50160)	3 × AC 380 V - 500 V, 50/60 Hz	
Nominal current I_N	AC 300 A	AC 600 A
Power loss at I_N P_V	180 W	44 W
Earth-leakage current at V_N	< 45 mA	< 6mA
Ambient temperature ϑ_U	-25 ... +40 °C	
Degree of protection	IP20 (EN 60529)	
Connections L1-L3/L1'-L3'	150 mm ² (AWG300-2)	M12 cable lugs
Tightening torque L1-L3/L1'-L3'	30 Nm	
Connection PE	M12	M12
Tightening torque PE	36 Nm	36 Nm
Assignment to AC 400/500 V units (MDX60/61B...-5_3)		
Rated operation (100 %)	1320	2500
Increased power (125 %)	1100/1320	1600/2000/2500
Assignment to AC 230 V units (MDX61B...-2_3)		
Rated operation (100 %)	-	-
Increased power (125 %)	-	-

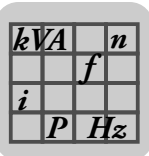

6.3.1 Dimension drawing for NF line filter

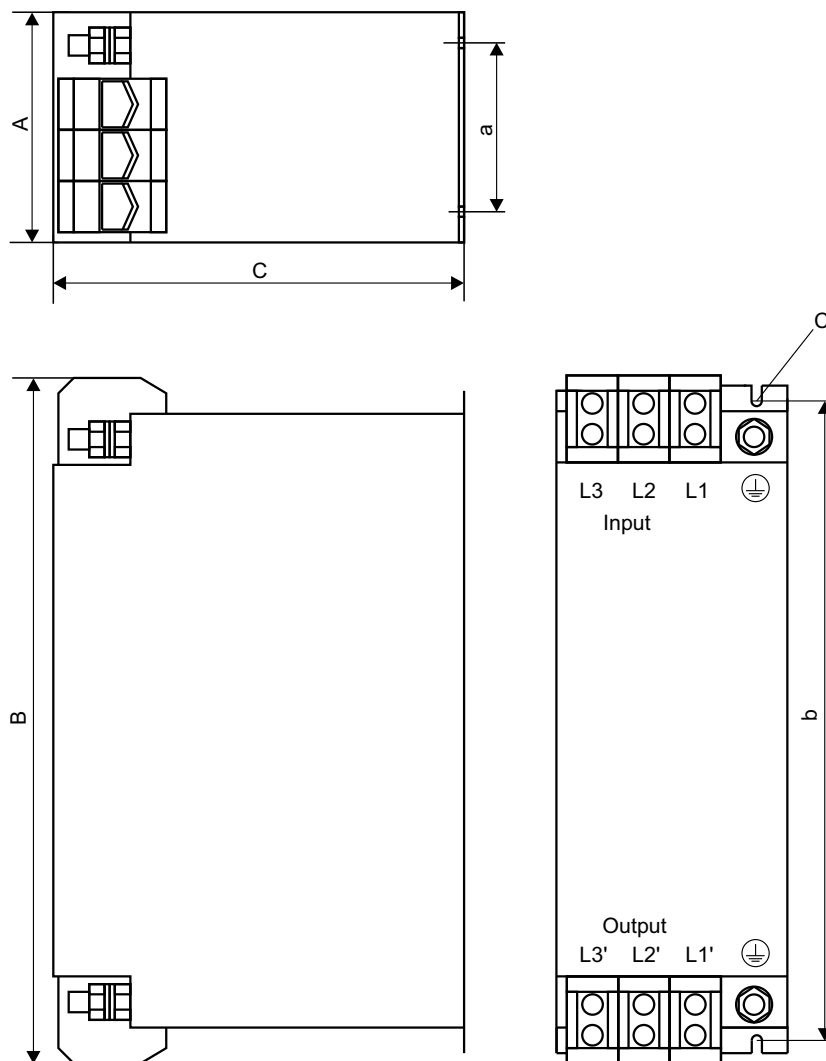

1456387083

Any mounting position

Line filter type	Main dimensions mm (in)			Mounting dimensions mm (in)		Hole dimension mm (in) c	PE connection	Mass kg (lb)
	A	B	C	a	b			
NF009-503	55 (2.2)	195 (7.68)	80 (3.1)	20 (0.78)	180 (7.09)	5.5 (0.22)	M5	0.8 (2)
NF014-503		225 (8.86)			210 (8.27)			0.9 (2)
NF018-503	50 (1.97)	255 (10)	30 (1.18)	240 (9.45)	1.1 (2.4)			
NF035-503	60 (2.36)	275 (10.8)		255 (10)	1.7 (3.7)			
NF048-503	90 (3.54)	315 (12.4)	100 (3.94)	60 (2.36)	295 (11.6)	6.5 (0.26)	M6	2.1 (4.6)
NF063-503		260 (10.2)			235 (9.25)			2.4 (5.3)
NF085-503	320 (12.6)	140 (5.51)	65 (2.56)	255 (10)	3.5 (7.7)			
NF115-503	100 (3.94)	330 (13)			155 (6.1)			4.8 (11)
NF150-503	140 (5.51)	450 (17.7)	190 (7.48)	102 (4.02)	365 (14.4)	M10	5.6 (12.3)	
NF210-503							170 (6.69)	540 (21.3)
NF300-503	170 (6.69)	540 (21.3)	230 (9.06)	125 (4.92)	435 (17.1)		M12	12.2 (26.9)

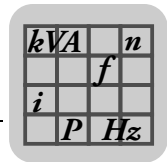

6.3.2 Dimension drawing of NF600-503 line filter

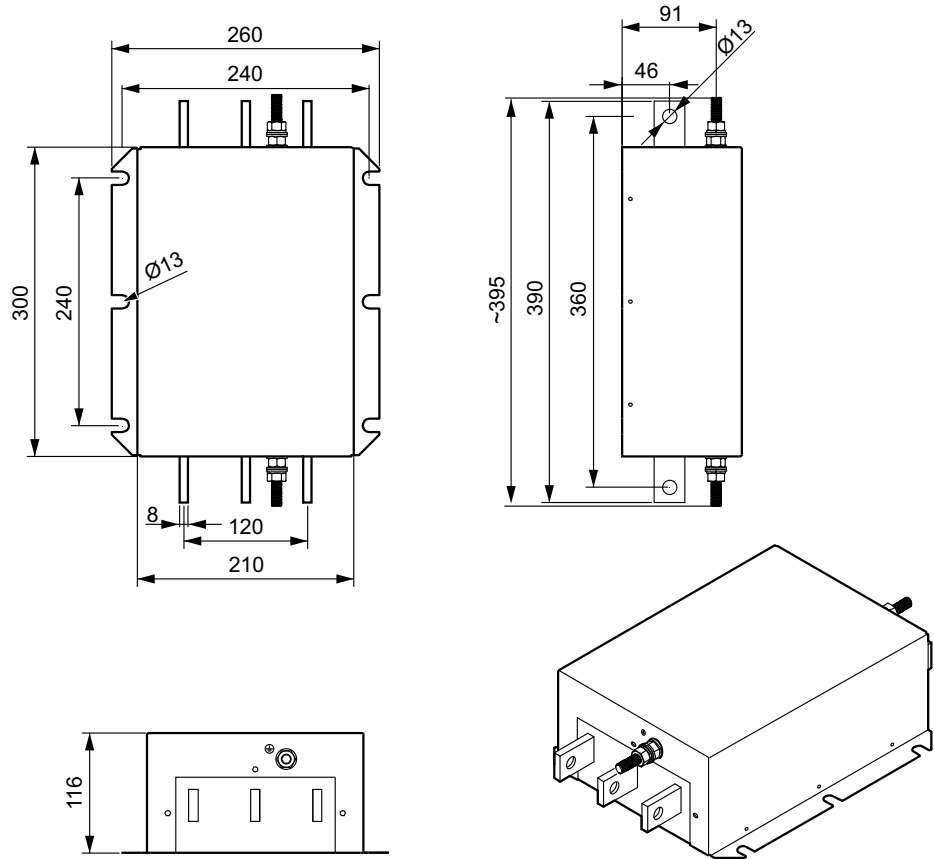

1456387083

Any mounting position

Line filter type	PE connection	Mass kg (lb)
NF600-503	M12	16.8 (37)

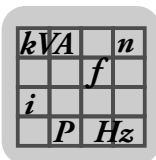

6.4 HD... output choke option

- For suppression of interference from the unshielded motor cable. For HD001 to HD003 we recommend routing the motor cable through the output choke with 5 loops. You can use less than 5 loops if the cable has a large diameter. Instead, connect 2 or 3 output chokes in series. If you use 4 loops, connect 2 output chokes in series, and if you use 3 loops, connect 3 output chokes.
- Output chokes HD001 to HD003 are allocated using the cable cross sections of the motor cables. Consequently, there is no separate assignment table for the AC 230 V units.
- The HD004 output choke is assigned to size 6 units (0900... 1320).
- The HD005 output choke is assigned to size 7 units (1600... 2500).

Output choke type	HD001 ¹⁾	HD002	HD003	HD004	HD005
Part number	813 325 5	813 557 6	813 558 4	816 885 7	1 796 336 2
Max. power loss P_{Vmax}	15 W	8 W	30 W	100 W	162
For cable cross sections/ connections/ Tightening torque	1.5...16 mm ² (AWG 16...6)	≤ 1.5 mm ² (AWG 16)	≥ 16 mm ² (AWG 6)	Terminal stud M12 36 Nm	Cable lugs M12 PE connection M12 36 Nm
Degree of protection	-	-	-	IP10	IP00

1) The HD.. output choke is not a UL/cUL-relevant component.

6.4.1 Dimension drawing of HD001 – HD003

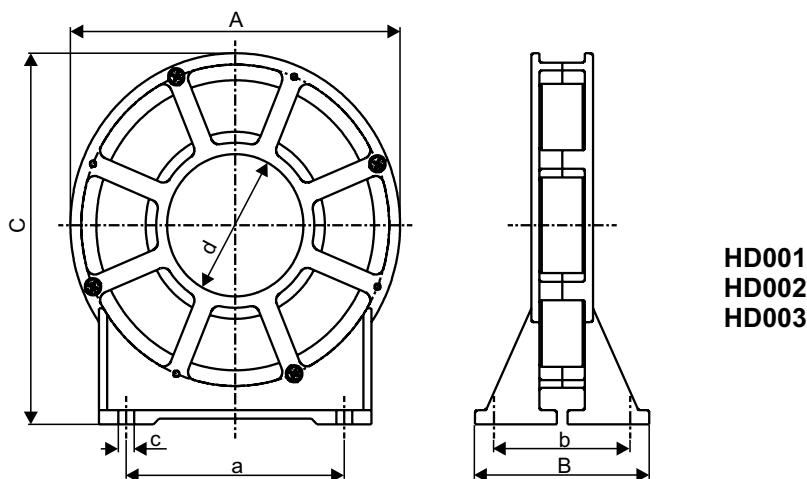

1456392203

Output choke type	Main dimensions mm (in)			Mounting dimensions mm (in)		Inner Ø mm (in)	Hole dimension mm (in)	Mass kg (lb)
	A	B	C	a	b			
HD001	121 (4.76)	64 (2.5)	131 (5.16)	80 (3.1)	50 (2.0)	50 (2.0)	5.8 (0.23)	0.5 (1)
HD002	66 (2.6)	49 (1.9)	73 (2.9)	44 (1.7)	38 (1.5)	23 (0.91)		0.2 (0.4)
HD003	170 (6.69)	64 (2.5)	185 (7.28)	120 (4.72)	50 (2.0)	88 (3.5)		7.0 (0.28)

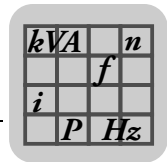

6.4.2 Dimension drawing of HD004

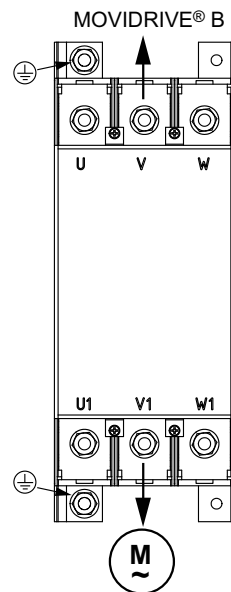
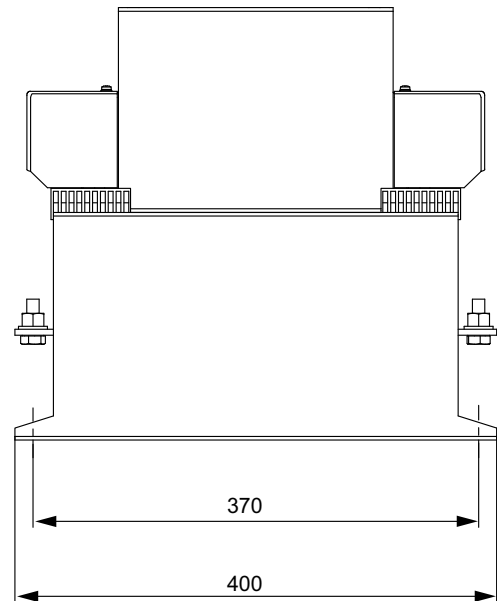
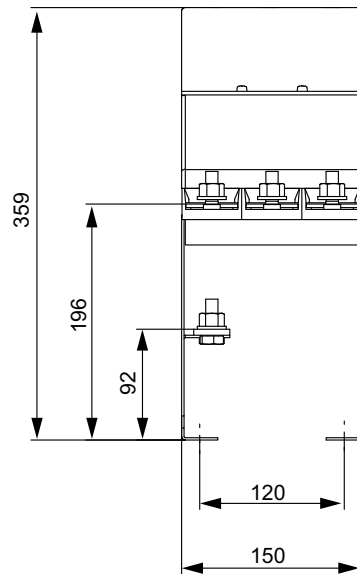

HD004

1457368587

Output choke type	Main dimensions mm (in)			Mounting dimensions mm (in)		Inner Ø mm (in)	Hole dimension mm (in)	Mass kg (lb)
	A	B	C	a	b			
HD004	150 (5.91)	400 (15.7)	360 (14.2)	120 (4.72)	370 (14.6)	-	9.0 (0.35)	12.5 (27.6)

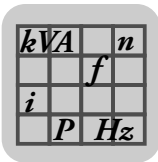

6.4.3 Dimension drawing of HD005

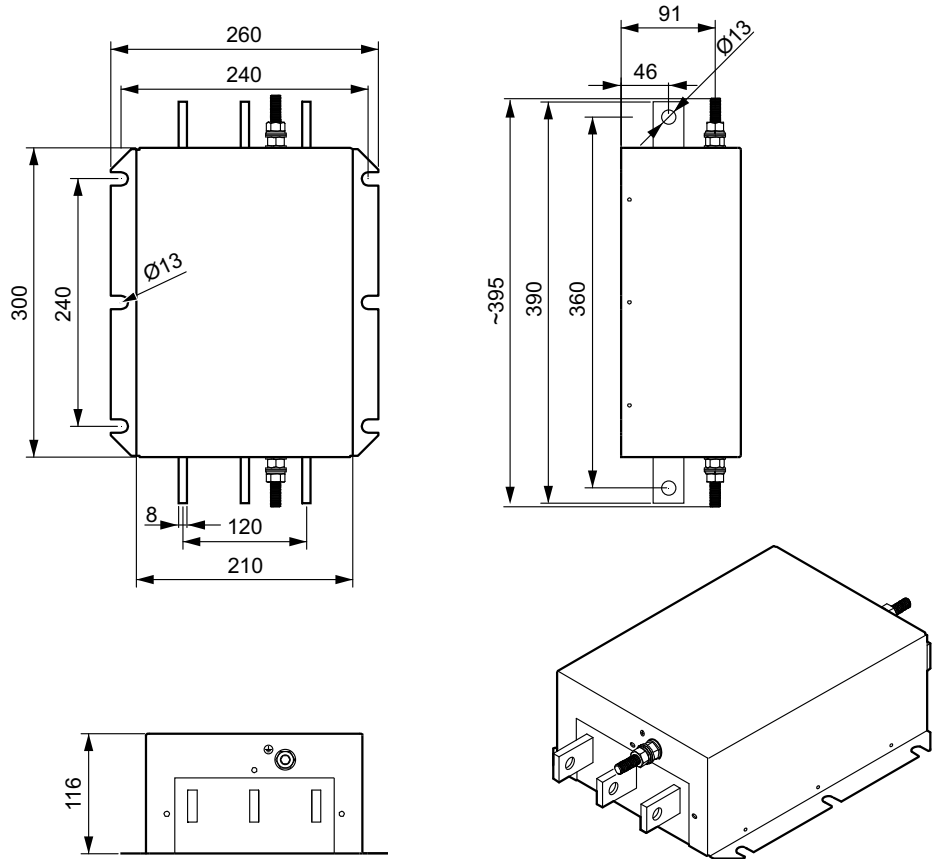

2435821579

Output choke type	PE connection	Mass kg (lb)
HD005	M12	16 (35.3)

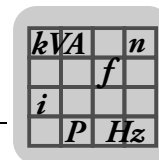

6.5 HF... output filter option

HF... output filters are sine filters used to smooth output voltage of inverters. HF... output filters (with the exception of HF450-503, HF180-403, HF325-403) are approved to UL/cUL in combination with MOVIDRIVE® inverters. HF... output filters are used in the following cases:

- In group drives (several motor leads in parallel); the discharge currents in the motor cables are suppressed.
- To protect the motor winding insulation of non-SEW motors which are not suitable for inverters
- For protection against overvoltage spikes in long motor cables (> 100 m)

Observe the following notes:

	INFORMATION
	<ul style="list-style-type: none"> • Operate output filters in V/f and VFC operating modes only. Do not use output filters in CFC and SERVO operating modes. • Do not use output filters in hoist applications. • During project planning of the drive, take the voltage drop in the output filter into account and the reduced motor torque that results. This applies particularly to AC 230 V units with output filters.

Output filter type	HF008-503 ¹⁾	HF015-503 ¹⁾	HF022-503 ¹⁾	HF030-503 ¹⁾	HF040-503 ¹⁾	HF055-503 ¹⁾
Part number	826 029 X	826 030 3	826 031 1	826 032 X	826 311 6	826 312 4
Nominal voltage V_N	3 × AC 230 V - 500 V, 50/60 Hz ²⁾					
Earth-leakage current at $U_N \Delta I$	0 mA					
Power loss at $I_N P_V$	25 W	35 W	55 W	65 W	90 W	115 W
Interference emission via unshielded motor cable	According to limit value class C1/C2 to EN 61800-3 ³⁾					
Ambient temperature ϑ_U	0 ... +45 °C (reduction: 3% I_N per K to max. 60 °C)					
Degree of protection (EN 60529)	IP20					
Connections / Tightening torque	M4 terminal studs 1.6 Nm ± 20 %					
Mass	3.1 kg (6.8 lb)	4.4 kg (9.7 lb)			10.8 kg (23.8 lb)	
Assignment to AC 400/500 V units (MDX60/61B...-5_3)						
Voltage drop at $I_N \Delta U$	< 6.5 % (7.5 %) at AC 400 V / < 4 % (5 %) at AC 500 V and $f_{Amax} = 50$ Hz (60 Hz)					
Nominal through current ⁴⁾ $I_{N 400 V}$ (at $V_{line} = 3 \times AC 400 V$)	AC 2.5 A	AC 4 A	AC 6 A	AC 8 A	AC 10 A	AC 12 A
Nominal through current $I_{N 500 V}$ (at $V_{line} = 3 \times AC 500 V$)	AC 2 A	AC 3 A	AC 5 A	AC 6 A	AC 8 A	AC 10 A
Rated operation (100 %) ³⁾	0005 ... 0011	0014 / 0015	0022	0030	0040	0055
Increased power (125 %) ³⁾	0005	0008 / 0011	0014 / 0015	0022	0030	0040
Assignment to AC 230 V units (MDX61B...-2_3)						
Voltage drop at $I_N \Delta U$	-	< 18.5 % (19 %) at AC 230 V with $f_{Amax} = 50$ Hz (60 Hz)				
Nominal through current $I_{N 230 V}$ (at $V_{line} = 3 \times AC 230 V$)	AC 4.3 A	AC 6.5 A	AC 10.8 A	AC 13 A	AC 17.3 A	AC 22 A
Rated operation (100 %) ³⁾	-	-	0015/0022	-	0037	0055
Increased power (125 %) ³⁾	-	-	0015/0022	-	-	0037

- 1) Approved to UL/cUL in combination with MOVIDRIVE® inverters. SEW-EURODRIVE will provide certification on request.
- 2) A reduction of 6 % I_N per 10 Hz applies above $f_A = 60$ Hz for the nominal through current I_N .
- 3) Observe the chapter on EMC-compliant installation according to EN 61800-3 in the SEW documentation.
- 4) Only applies for operation without U_z connection. For operating the inverter with U_z connection, observe the project planning notes in the system manual of the respective inverter.

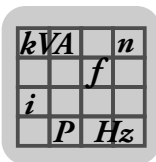

Technical Data of Braking Resistors, Chokes, and Filters

HF... output filter option

Output filter type	HF075-503 ¹⁾	HF023-403 ¹⁾	HF033-403 ¹⁾	HF047-403 ¹⁾	HF450-503	HF180-403	HF325-403
Part number	826 313 2	825 784 1	825 785 X	825 786 8	826 948 3	0 829 909 9	0 829 910 2
Nominal voltage V_N	3 × AC 230 V - 500 V, 50/60 Hz ²⁾						
Earth-leakage current at $U_N \Delta I$	0 mA						
Power loss at $I_N P_V$	135 W	90 W	120 W	200 W	400 W	860 W	1430 W
Interference emission via unshielded motor cable	According to limit value class C1/C2 to EN 61800-3 ³⁾						
Ambient temperature ϑ_U	0 ... +45 °C (reduction: 3% I_N per K to max. 60 °C)					-25 ... +85 °C	
Degree of protection (EN 60529)	IP 20	IP20			IP 10	IP00	IP00
Connections / Tightening torque	M4 terminal studs 1.6 Nm ± 20 %	35 mm ² (AWG 2) 3.2 Nm				M10 terminal studs / 70 mm ² (AWG 3/0) 30 Nm (270 lb in)	
Mass	10.8 kg (23.8 lb)	15.9 kg (35.1 lb)	16.5 kg (36.4 lb)	23 kg (51 lb)	32 kg (71 lb)	85.3 kg (188 lb)	170 kg (375 lb)
Assignment to AC 400/500 V units (MDX60/61B...-5_3)							
Voltage drop at $I_N \Delta U$	< 6.5 % (7.5 %) at AC 400 V / < 4 % (5 %) at AC 500 V and $f_{Amax} = 50$ Hz (60 Hz)						
Nominal through current ⁴⁾ $I_{N 400 V}$ (at $V_{line} = 3 \times AC 400 V$)	AC 16 A	AC 23 A	AC 33 A	AC 47 A	AC 90 A	AC 180 A	AC 325 A
Nominal through current $I_{N 500 V}$ (at $V_{line} = 3 \times AC 500 V$)	AC 13 A	AC 19 A	AC 26 A	AC 38 A	AC 72 A	AC 180 A	AC 325 A
Nominal operation (100 %) ³⁾	0075	0110	0150/0300	0220	0370/0450/ 0550 ⁵⁾ / 0750 ⁴⁾ / 0900 ⁴⁾	0550/0750/ 0900	1100/1320
Increased power (125 %) ³⁾	0055	0075	0110/0220	0150	0300/0370/ 0450 /0550 ⁴⁾ / 0750 ⁴⁾	0550/0750	0990/110/ 1320
Assignment to AC 230 V units (MDX61B...-2_3)							
Voltage drop at $I_N \Delta U$	< 18.5 % (19 %) at AC 230 V with $f_{Amax} = 50$ Hz (60 Hz)						
Nominal through current $I_{N 230 V}$ (at $V_{line} = 3 \times AC 230 V$)	AC 29 A	AC 42 A	AC 56.5 A	AC 82.6 A	AC 156 A	-	-
Nominal operation (100 %) ³⁾	0075	0110	0150/0300 ⁴⁾	0220	0300	-	-
Increased power (125 %) ³⁾	0055	0075	0110/0220 ⁴⁾	0150	0220/0300	-	-

- 1) Approved to UL/cUL in combination with MOVIDRIVE[®] inverters. SEW-EURODRIVE will provide certification on request.
- 2) A reduction of 6 % I_N per 10 Hz applies above $f_A = 60$ Hz for the nominal through current I_N .
- 3) Observe the chapter on EMC-compliant installation according to EN 61800-3 in the SEW documentation.
- 4) Only applies for operation without DC link connection. For operation with DC link connection, observe the project planning instructions in the MOVIDRIVE[®] MDX60/61B system manual, chapter "Project planning/connecting the optional power components".
- 5) Connect two HF...-... output filters in parallel for operation with these MOVIDRIVE[®] units.

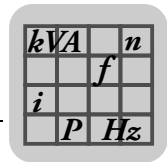

6.5.1 Dimension drawings of HF...-503 output filters

HF008 / 015 / 022 / 030-503

HF040/055/075-503

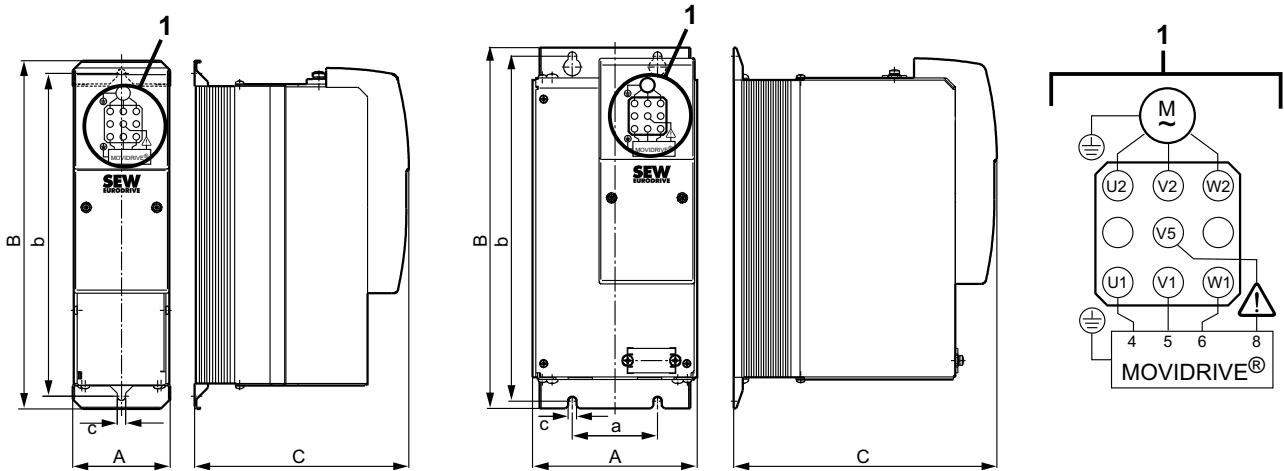

1472824587

Only the mounting position shown in the dimension drawing is permitted.

Output filter type	Main dimensions mm (in)			Mounting dimensions mm (in)		Hole dimension mm (in)	Ventilation clearances ¹⁾ mm (in)	
	A	B	C	a	b		Above	Below
HF008 / 015 / 022 / 030-503	80 (3.1)	286 (11.3)	176 (6.93)	-	265 (10.4)	7 (0.3)	100 (3.94)	100 (3.94)
HF040/055/075-503	135 (5.31)	296 (11.7)	216 (8.5)	70 (2.8)	283 (11.1)			

1) There is no need for clearance at the sides. You can line up the units next to one another.

HF450-503

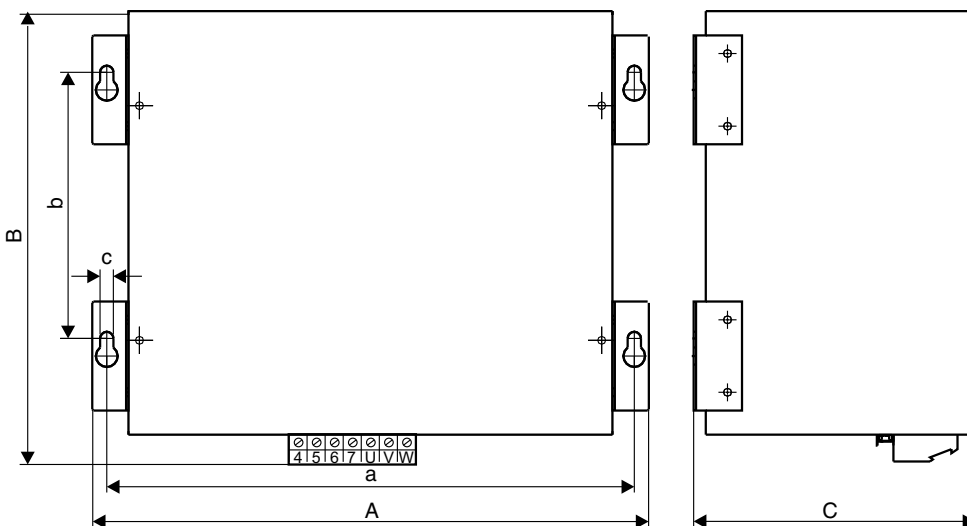

1472827659

Only the mounting position shown in the dimension drawing is permitted

Output filter type	Main dimensions mm (in)			Mounting dimensions mm (in)		Hole dimension mm (in)	Ventilation clearances mm (in)	
	A	B	C	a	b		Above	Below
HF450-503	465 (18.3)	385 (15.2)	240 (9.45)	436 (17.2)	220 (8.66)	8.5 (0.33)	100 (3.94)	100 (3.94)

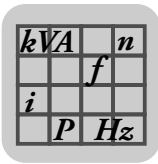

6.5.2 Dimension drawings of HF...-403 output filters

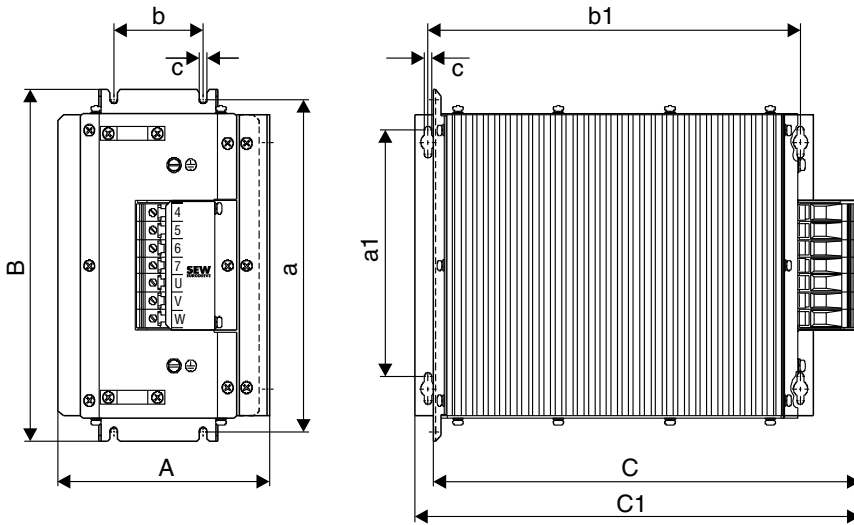

1472830731

Type	Main dimensions mm (in)			Mounting dimensions mm (in)				Hole dimens. mm (in)	Ventilation clearances mm (in)		
	A	B	C/C1	Standard mounting position		Horizontal mounting pos.			Side	Above	Below
HF023-403	145 (5.71)	284 (11.2)	365/390 (14.4/15.4)	268 (10.6)	60 (2.4)	210 (8.27)	334 (13.1)	6.5 (0.26)	30 (1.2) each	150 (5.91)	150 (5.91)
HF033-403											
HF047-403	190 (7.48)	300 (11.8)	385/400 (15.2/15.7)	284 (11.2)	80 (3.1)						

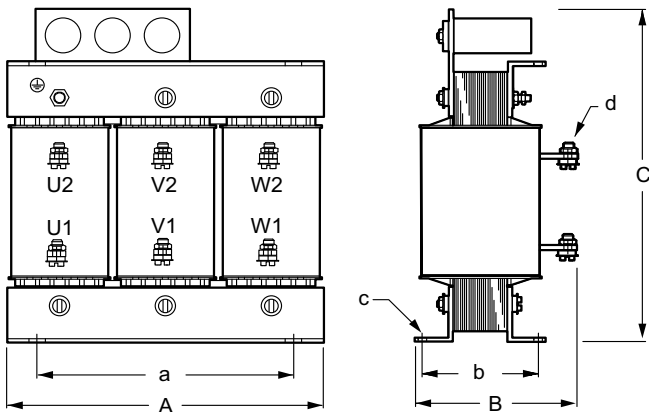

2705456011

The ring cable lug must be attached directly to the copper clip.
Only the mounting position shown in the dimension drawing is permitted

Output filter type	Main dimensions mm (in)			Mounting dimensions mm (in)		Hole dimension mm (in)		Ventilation clearances mm (in)		
	A	B	C	a	b	c	d	Side	Above	Below
HF180-403	480 (18.9)	260 (10.2)	510 (20.1)	430 (16.9)	180 (7.1)	18 x 13 (0.71 x 0.51)	11 (0.43)	192 each (7.6)	510 (20.1)	510 (20.1)
HF325-403	480 (18.9)	300 (11.8)	730 (28.7)	430 (16.9)	230 (9.1)	18 x 13 (0.71 x 0.51)	11 (0.43)	192 each (7.6)	730 (28.7)	730 (28.7)



7 Prefabricated Cables

7.1 Overview

SEW-EURODRIVE offers cable sets and prefabricated cables for straightforward and error-free connection of various system components to MOVIDRIVE®. The cables are pre-fabricated in 1 m steps to the required length. It is necessary to differentiate between whether the cables are intended for fixed routing or for cable carrier applications.

1. Cable sets for DC link connection MDR → MDX
2. Motor cables and extension cables for connecting CM motors
3. Motor cables and extension cables for connecting DS, CMD and CMP motors.
4. Connection to DEH11B/DEH21B/DEU21B/DER11B: Encoder cable and extensions cable (Hiperface®, incremental encoder), resolver cable and extension cable in plug and terminal box design for motors.

7.2 Cable sets for DC link connection MDR → MDX

7.2.1 Description

SEW-EURODRIVE strongly recommends using the cable sets listed in the table below. These cable sets offer the appropriate dielectric strength and are also color-coded. Color coding is necessary because cross-polarity and ground faults could cause irreparable damage to the connected equipment.

The length of the cables restricts the DC link connection to the permitted length of 5 m. They can also be cut to length by the customer for connecting several units. The lugs for connection to the regenerative power supply unit and an inverter are supplied with the cable set. Use commercially available cable lugs to connect other inverters. In this case, connect inverters in star configuration to the regenerative power supply unit. Use a bus bar subdistributor if the DC link terminals of the regenerative power supply unit are not sufficient.

7.2.2 Installation type

Only fixed routing is possible.

Cable set type	DCP12A	DCP13A	DCP15A	DCP16A
Part number	814 567 9	814 250 5	814 251 3	817 593 4
For connecting MOVIDRIVE®	0015...0110	0150...0370	0450...0750	0900...1320



Prefabricated Cables

CM motor cables with connector on motor end

7.3 CM motor cables with connector on motor end

7.3.1 Motor cable:

Number of cores and Cable cross section	Part number	Installation type	for motor
4×1.5 mm ²	199 179 5	Fixed installation	CM..SM51/61
4×2.5 mm ²	199 181 7		CM..SM52/62
4×4 mm ²	199 183 3		CM..SM54/64
4×6 mm ²	199 185 X		CM..SM56/66
4×10 mm ²	199 187 6		CM..SM59/59

Number of cores and Cable cross section	Part number	Installation type	for motor
4×1.5 mm ²	1 333 114 0	Cable carrier installation	CM..SM51/61
4×2.5 mm ²	1 333 115 9		CM..SM52/62
4×4 mm ²	0 199 184 1		CM..SM54/64
4×6 mm ²	0 199 186 8		CM..SM56/66
4×10 mm ²	0 199 188 4		CM..SM59/59

7.3.2 Extension cable:

Number of cores and Cable cross section	Part number	Installation type	for motor
4×1.5 mm ²	199 549 9	Fixed installation	CM..SM51/61
4×2.5 mm ²	199 551 0		CM..SM52/62
4×4 mm ²	199 553 7		CM..SM54/64
4×6 mm ²	199 555 3		CM..SM56/66
4×10 mm ²	199 557 X		CM..SM59/59

Number of cores and Cable cross section	Part number	Installation type	for motor
4×1.5 mm ²	1 333 118 3	Cable carrier installation	CM..SM51/61
4×2.5 mm ²	1 333 119 1		CM..SM52/62
4×4 mm ²	0 199 554 5		CM..SM54/64
4×6 mm ²	0 199 556 1		CM..SM56/66
4×10 mm ²	0 199 558 8		CM..SM59/59



7.4 CM brakemotor cables with connector on motor end

7.4.1 Motor cable:

Number of cores and Cable cross section	Part number	Installation type	for motor
4×1.5 mm ² + 3×1.0 mm ²	199 189 2	Fixed installation	CM..BR SB51/61
4×2.5 mm ² + 3×1.0 mm ²	199 191 4		CM..BR SB52/62
4×4 mm ² + 3×1.0 mm ²	199 193 0		CM..BR SB54/64
4×6 mm ² + 3×1.5 mm ²	199 195 7		CM..BR SB56/66
4×10 mm ² + 3×1.5 mm ²	199 197 3		CM..BR SB59/69

Number of cores and Cable cross section	Part number	Installation type	for motor
4×1.5 mm ² + 3×1.0 mm ²	1 333 116 7	Cable carrier installation	CM..BR SB51/61
4×2.5 mm ² + 3×1.0 mm ²	1 333 117 5		CM..BR SB52/62
4×4 mm ² + 3×1.0 mm ²	0 199 194 9		CM..BR SB54/64
4×6 mm ² + 3×1.5 mm ²	0 199 196 5		CM..BR SB56/66
4×10 mm ² + 3×1.5 mm ²	0 199 198 1		CM..BR SB59/69

7.4.2 Extension cable:

Number of cores and Cable cross section	Part number	Installation type	for motor
4×1.5 mm ² + 3×1.0 mm ²	199 199 X	Fixed installation	CM..BR SB51/61
4×2.5 mm ² + 3×1.0 mm ²	199 201 5		CM..BR SB52/62
4×4 mm ² + 3×1.0 mm ²	199 203 1		CM..BR SB54/64
4×6 mm ² + 3×1.5 mm ²	199 205 8		CM..BR SB56/66
4×10 mm ² + 3×1.5 mm ²	199 207 4		CM..BR SB59/69

Number of cores and Cable cross section	Part number	Installation type	for motor
4×1.5 mm ² + 3×1.0 mm ²	1 333 120 5	Cable carrier installation	CM..BR SB51/61
4×2.5 mm ² + 3×1.0 mm ²	1 333 121 3		CM..BR SB52/62
4×4 mm ² + 3×1.0 mm ²	0 199 204 X		CM..BR SB54/64
4×6 mm ² + 3×1.5 mm ²	0 199 206 6		CM..BR SB56/66
4×10 mm ² + 3×1.5 mm ²	0 199 208 2		CM..BR SB59/69



7.5 CMD/CMP motor cables with connector on motor end

7.5.1 Motor cable:

Number of cores and Cable cross section	Part number	Installation type	for motor
4×1.5 mm ²	0 590 454 4	Cable carrier installation	CMD.. / CMP.. SM11
4×2.5 mm ²	0 590 455 2		CMD.. / CMP.. SM12
4×4 mm ²	0 590 456 0		CMD.. / CMP.. SM14

Number of cores and Cable cross section	Part number	Installation type	for motor
4×1.5 mm ²	0 590 624 5	Cable carrier installation	CMD.. / CMP.. SM11
4×2.5 mm ²	0 590 625 3		CMD.. / CMP.. SM12
4×4 mm ²	0 590 480 3		CMD.. / CMP.. SM14

7.5.2 Extension cable:

Number of cores and Cable cross section	Part number	Installation type	for motor
4×1.5 mm ²	1 333 245 7	Cable carrier installation	CMD.. / CMP.. SM11
4×2.5 mm ²	1 333 246 5		CMD.. / CMP.. SM12
4×4 mm ²	1 333 247 3		CMD.. / CMP.. SM14

7.6 CMP brakemotor cables for BP brake with connector at motor end

7.6.1 Brakemotor cable:

Number of cores and Cable cross section	Part number	Installation type	for motor
4×1.5 mm ² + 3×1 mm ²	1 335 434 5	Fixed installation	SB11
4×2.5 mm ² + 3×1 mm ²	1 335 435 3		SB12
4×4 mm ² + 3×1 mm ²	1 335 436 1		SB14
4×6 mm ² + 3×1.5 mm ²	1 335 019 6		SBB6
4×10 mm ² + 3×1.5 mm ²	1 335 021 8		SBB10
4×16 mm ² + 3×1.5 mm ²	1 335 022 6		SBB16

Number of cores and Cable cross section	Part number	Installation type	for motor
4×1.5 mm ² + 3×1 mm ²	1 335 438 8	Cable carrier installation	SB11
4×2.5 mm ² + 3×1 mm ²	1 335 439 6		SB12
4×4 mm ² + 3×1 mm ²	1 342 160 3		SB14
4×6 mm ² + 3×1.5 mm ²	1 335 023 4		SBB6
4×10 mm ² + 3×1.5 mm ²	1 335 024 2		SBB10
4×16 mm ² + 3×1.5 mm ²	1 335 025 0		SBB16



7.6.2 Extension cable:

Number of cores and Cable cross section	Part number	Installation type	for motor
4×1.5 mm ² + 3×1 mm ²	1 335 422 1	Cable carrier installation	SB11
4×2.5 mm ² + 3×1 mm ²	1 335 424 8		SB12
4×4 mm ² + 3×1 mm ²	1 335 433 7		SB14
4×6 mm ² + 3×1.5 mm ²	1 335 009 9		SBB6
4×10 mm ² + 3×1.5 mm ²	1 335 010 2		SBB10
4×16 mm ² + 3×1.5 mm ²	1 335 011 0		SBB16

7.7 CMP brakemotor cables for BY brake with connector at motor end

7.7.1 Brakemotor cable:

Number of cores and Cable cross section	Part number	Installation type	for motor
4×1.5 mm ² + 3×1 mm ²	1 335 427 2	Fixed installation	SB11
4×2.5 mm ² + 3×1 mm ²	1 335 428 0		SB12
4×4 mm ² + 3×1 mm ²	1 335 429 9		SB14
4×6 mm ² + 3×1.5 mm ²	1 335 012 9		SBB6
4×10 mm ² + 3×1.5 mm ²	1 335 013 7		SBB10
4 × 16 mm ² + 3×1.5 mm ²	1 335 014 5		SBB16

Number of cores and Cable cross section	Part number	Installation type	for motor
4×1.5 mm ² + 3×1 mm ²	1 335 430 2	Cable carrier installation	SB11
4×2.5 mm ² + 3×1 mm ²	1 335 431 0		SB12
4×4 mm ² + 3×1 mm ²	1 342 432 9		SB14
4×6 mm ² + 3×1.5 mm ²	1 335 015 3		SBB6
4×10 mm ² + 3×1.5 mm ²	1 335 016 1		SBB10
4×16 mm ² + 3×1.5 mm ²	1 335 018 8		SBB16

7.7.2 Extension cable:

Number of cores and Cable cross section	Part number	Installation type	for motor
4×1.5 mm ² + 3×1 mm ²	1 335 422 1	Cable carrier installation	SB11
4×2.5 mm ² + 3×1 mm ²	1 335 424 8		SB12
4×4 mm ² + 3×1 mm ²	1 335 433 7		SB14
4×6 mm ² + 3×1.5 mm ²	1 335 009 9		SBB6
4×10 mm ² + 3×1.5 mm ²	1 335 010 2		SBB10
4×16 mm ² + 3×1.5 mm ²	1 335 011 0		SBB16



7.8 Encoder cable selection: Meaning of the symbols

The connection cables are assigned a part number and a symbol. The symbols have the following meaning:

Symbol	Meaning
	Connection cable connector → connector for fixed installation
	Extension connection cable connector → connector for fixed installation
	Connection cable connector → connector for cable carrier installation
	Extension connection cable connector → connector for cable carrier installation
	Connection cable connector → terminal box for fixed installation
	Connection cable connector → terminal box for cable carrier installation
	Connection cable connector → Y connector for fixed installation
	Connection cable connector → Y connector for cable carrier installation
	Connection cable connector → connector with crossed A/B track for reversing the direction of rotation (for fixed installation)
	Connection cable connector → encoder connection cover for fixed installation
	Connection cable connector → encoder connection cover for cable carrier installation
	Encoder connection via plug connector
	Encoder connection via encoder terminal strip
	Encoder connection via encoder connection cover
	Connection via plug connector on the motor side
	Connection via terminal box on the motor side
	Connection via encoder connection cover on the motor side



7.9 Encoder cable for DR motors on X15 DEH11B/DEH21B/DEU21B

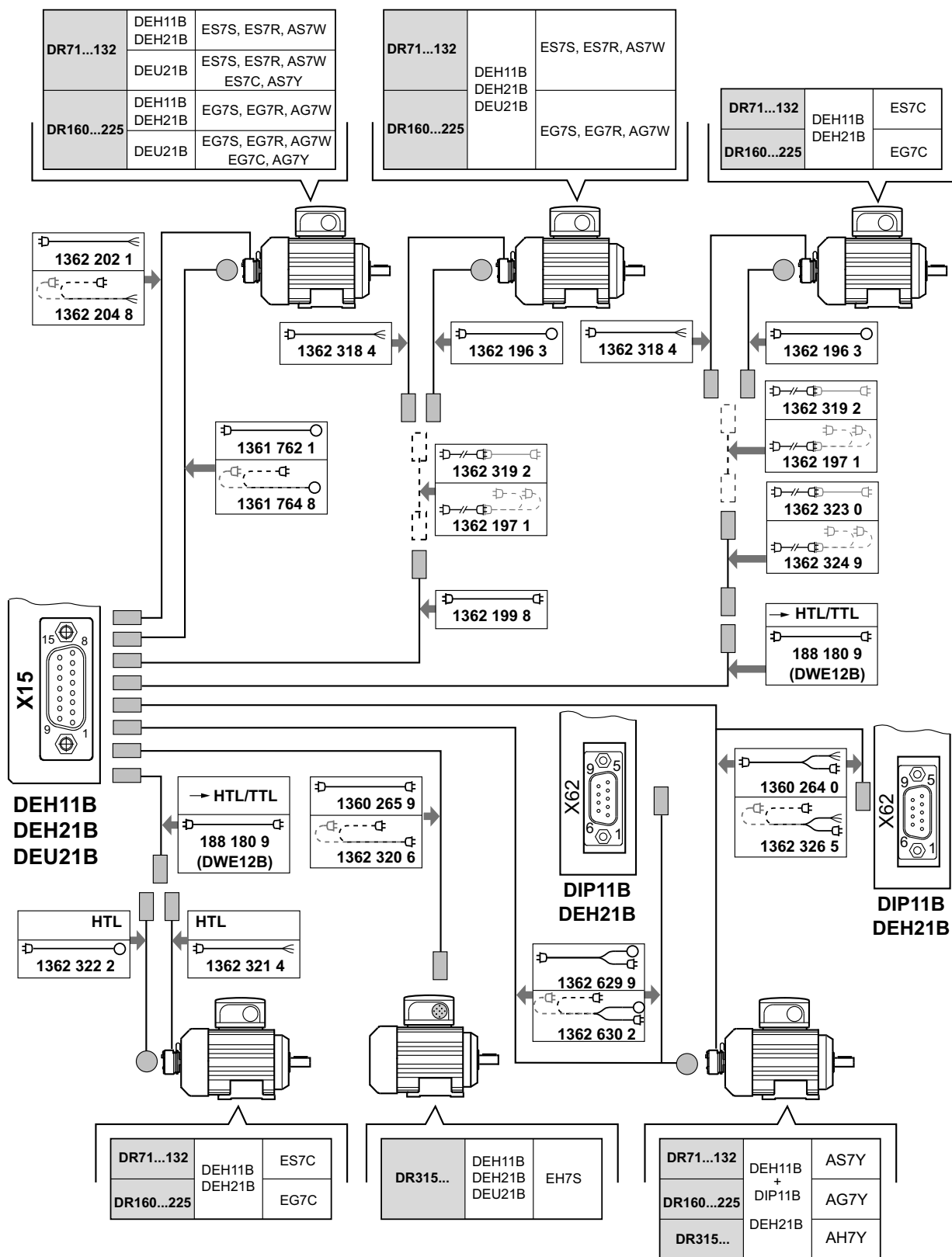

2701623051

For the individual wiring diagrams, refer to the section "Installation" in the MOVIDRIVE® MDX60B/61B operating instructions.



Prefabricated Cables

Encoder cable for DR motors on X15 DEH11B/DEH21B/DEU21B

7.9.1 Required prefabricated cables

- Part number: 1361 762 1 or 1361 764 8
- Cable with D-sub 15 plug connector and encoder connection cover:

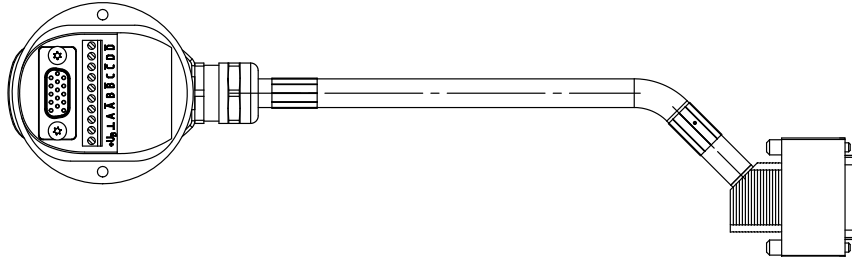

- Part number 1362 202 1 or 1362 204 8
- Cable with D-sub 15 plug connector and conductor end sleeves:

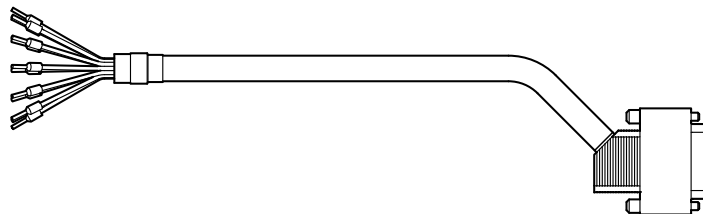

Motor size	Encoder type	Encoder cables	
		Installation	Part number
DR71 – 132 DR160 – 225 DR315	ES7S, ES7R, ES7C, AS7W, AS7Y EG7S, EG7R, EG7C, AG7W, AG7Y, AH7Y		1361 762 1
			1361 764 8
DR71 – 132 DR160 – 225 DR315	ES7S, ES7R, ES7C, AS7W, AS7Y EG7S, EG7R, EG7C, AG7W, AG7Y, AH7Y		1362 202 1
			1362 204 8



- Part number: 1362 196 3
- Cable with encoder connection cover and M23 plug connector:

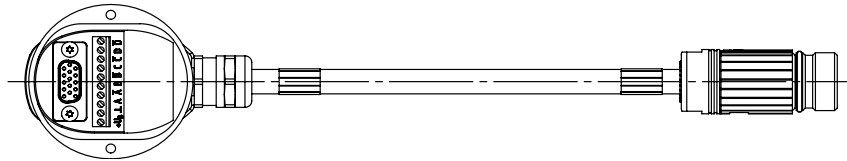

- Part number: 1362 318 4
- Cable with conductor end sleeves and M23 plug connector:

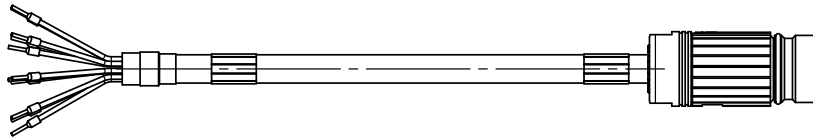

- Part number: 1362 319 2 or 1362 197 1
- Optional: Extension cable with M23 plug connector on both sides:

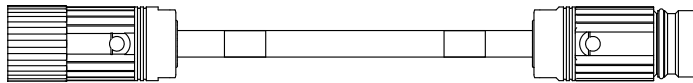

- Part number: 1362 199 8
- Cable with M23 plug connector and D-sub 15 plug connector:

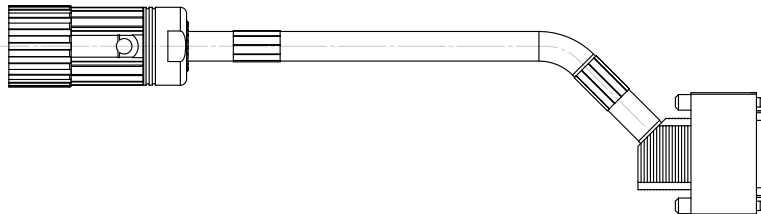

Motor size	Encoder type	Encoder cables	
		Installation	Part number
DR71 – 132 DR160 – 225	ES7S, ES7R, ES7C, AS7W, AS7Y, EG7S, EG7R, EG7C, AG7W, AG7Y		1362 196 3
			1362 318 4
			1362 319 2
			1362 197 1
			1362 199 8



Prefabricated Cables

Encoder cable for DR motors on X15 DEH11B/DEH21B/DEU21B

- Part number: 1362 322 2
- Cable with D-sub 9 plug connector and encoder connection cover:

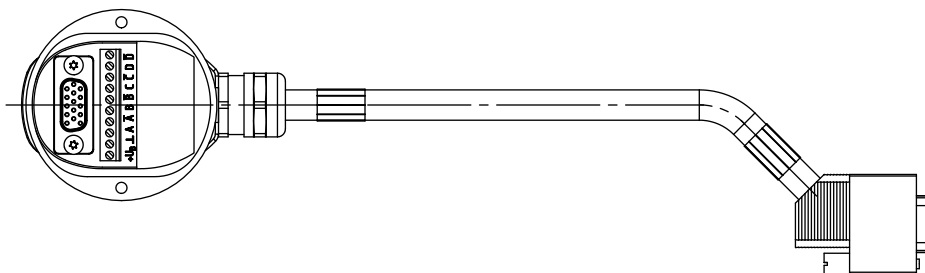

- Part number: 1362 321 4
- Cable with D-sub 9 plug connector and conductor end sleeves:

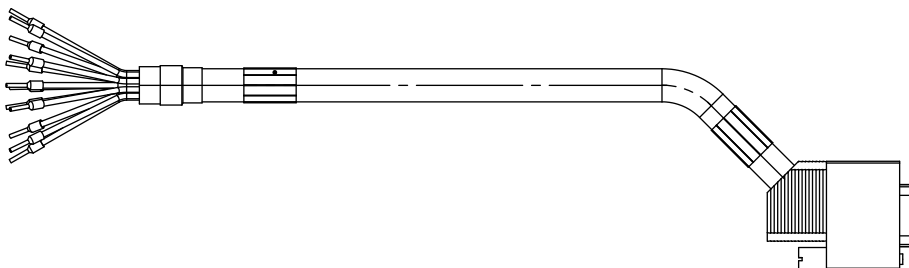

- Part number 188 180 9
- DWE12B option, interface adapter HTL→ TTL (length: 1 m):

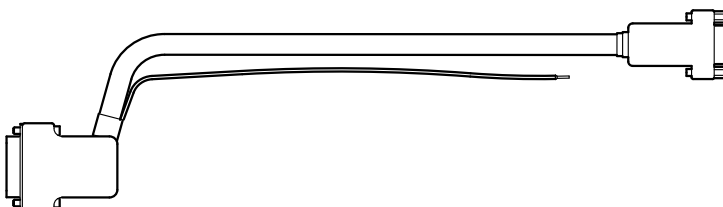

Motor size	Encoder type	Encoder cables	
		Installation	Part number
DR71 – 132 DR160 – 225	ES7C, EG7C,		1362 322 2
			1362 321 4
			188 180 9 (DWE12B)



- Part number: 1362 196 3
- Possibility 1: Cable with encoder connection cover and M23 plug connector:

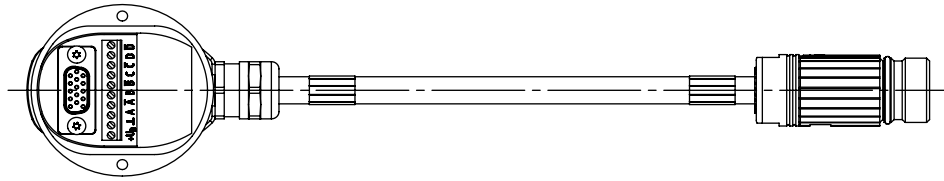

- Part number: 1362 318 4
- Cable with M23 plug connector and conductor end sleeves:

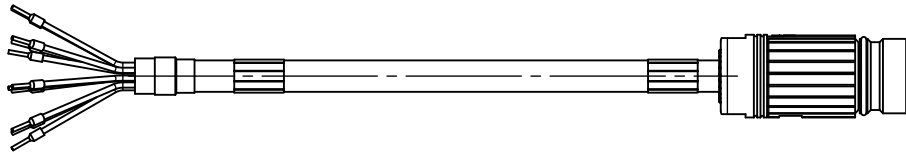

- Part number: 1362 197 1
- Extension cable with M23 plug connector on both sides:

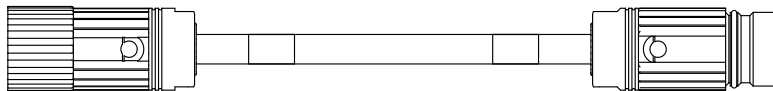

- Part number: 1362 323 0 or 1362 324 9
- Extension cable with M23 plug connector and D-sub 9 plug connector:

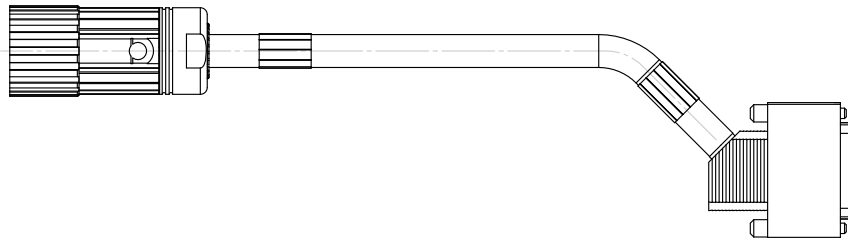

- Part number: 188 180 9
- DWE12B option, interface adapter HTL→ TTL (length: 1 m):

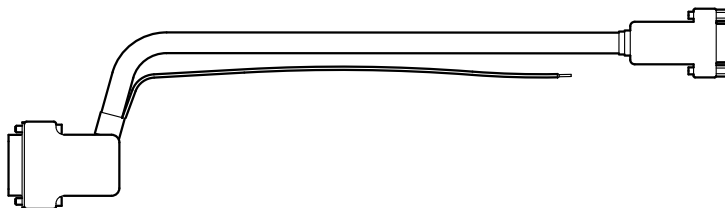



Prefabricated Cables

Encoder cable for DR motors on X15 DEH11B/DEH21B/DEU21B

Motor size	Encoder type	Encoder cables	
		Installation	Part number
DR71 – 132 DR160 – 225	ES7C, EG7C,		1362 196 3
			1362 318 4
			1362 319 2
			1362 197 1
			1362 323 0
			1362 324 9
			188 180 9 (DWE12B)

- Part number: 1360 265 9 or 1362 320 6
- Cable with M23 plug connector and D-sub 15 plug connector:

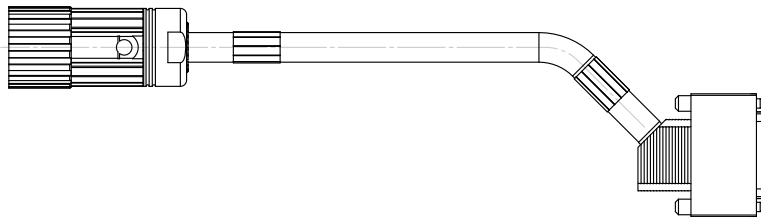

Motor size	Encoder type	Encoder cables	
		Installation	Part number
DR315	EH7S		1360 265 9
			1362 320 6



- Part number: 1362 629 9 or 1362 630 2
- Possibility 1: Y-cable with D-sub 15 plug connector, D-sub 9 plug connector and encoder connection cover:

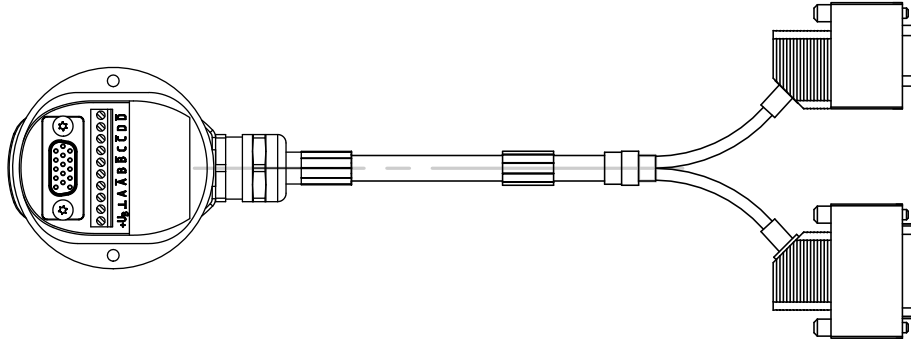

- Part number: 13660 264 0 or 1362 326 5
- Possibility 2: Y-cable with D-sub 15 plug connector, D-sub 9 plug connector and conductor end sleeves:

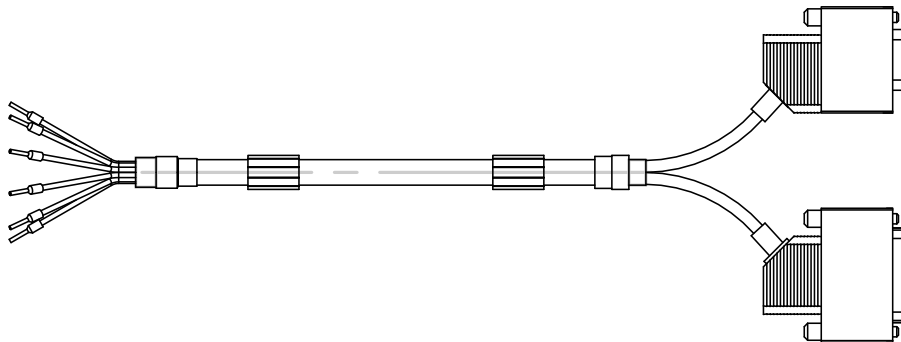

Motor size	Encoder type	Encoder cables	
		Installation	Part number
DR71 – 132 DR160 – 225 DR315	AS7Y AG7Y AH7Y		1362 629 9
			1362 630 2
			1360 264 0
			1362 326 5



Prefabricated Cables

Encoder cable for DT/DV/CMP, CM, (DS) motors on X15 DEH11B/DEH21B

7.10 Encoder cable for DT/DV/CMP, CM, (DS) motors on X15 DEH11B/DEH21B and DEU21B

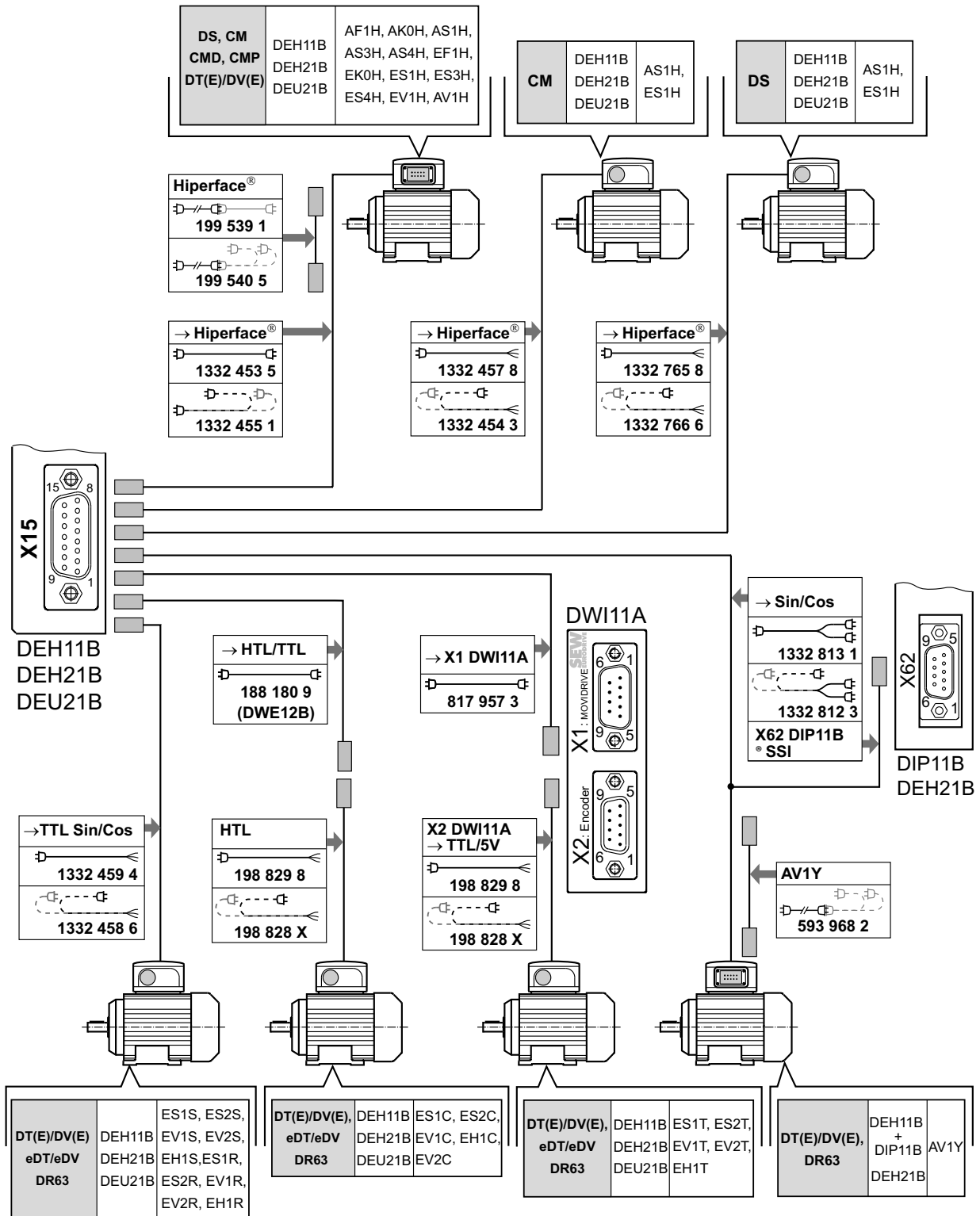

2704469387

For the individual wiring diagrams, refer to the section "Installation" in the MOVIDRIVE® MDX60B/61B operating instructions. When combining SSI or HTL encoders with the DEU21B multi-encoder card, refer to the "MOVIDRIVE® DEU21B Multi-Encoder Card" manual.



- Part number: 1332 453 5 or 1332 455 1
- Cable for encoder connection with plug connector on motor end.

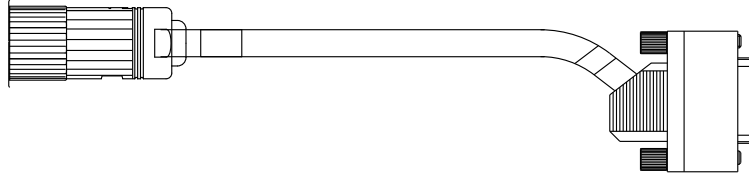

- Part number: 199 539 1 or 199 540 5
- Extension cable for encoder connection with plug connector on motor end.

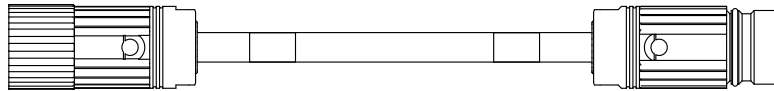

Motor series	Encoder type	Encoder cable	
		Installation	Part number
DS/CM/CMD/CMP/DT/DV/DT(E)/DV(E) motors	AF1H, AK0H, AS1H, AS3H, AS4H, EF1H, EK0H, ES1H, ES3H, ES4H, EV1H, AV1H		1332 453 5
			1332 455 1
			199 539 1
			199 540 5

- Part number: 1332 457 8 or 1332 454 3
- Cable for encoder connection with terminal box connection on motor end.

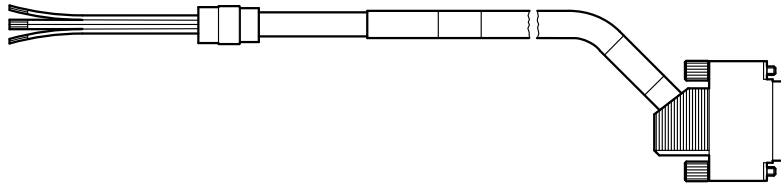

Motor series	Encoder type	Encoder cable	
		Installation	Part number
CM motors	AS1H, ES1H, AF1H, EF1H		1332 457 8
			1332 454 3



Prefabricated Cables

Encoder cable for DT/DV/CMP, CM, (DS) motors on X15 DEH11B/DEH21B

- Part number: 1332 765 8 or 1332 766 6
- Cable for encoder connection with terminal box connection on motor end.

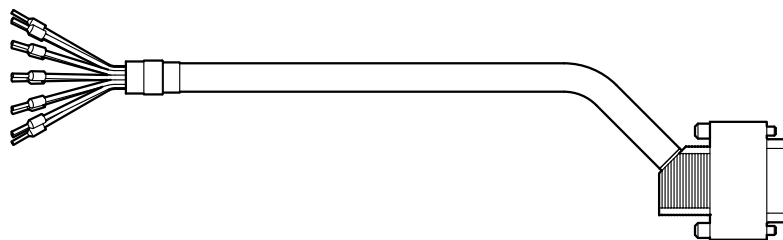

Motor series	Encoder type	Encoder cable	
		Installation	Part number
DS motors	AS1H, ES1H, AF1H, EF1H		1332 765 8
			1332 766 6

- Part number: 1332 459 4 or 1332 458 6
- Cable for encoder connection with terminal box connection on motor end.

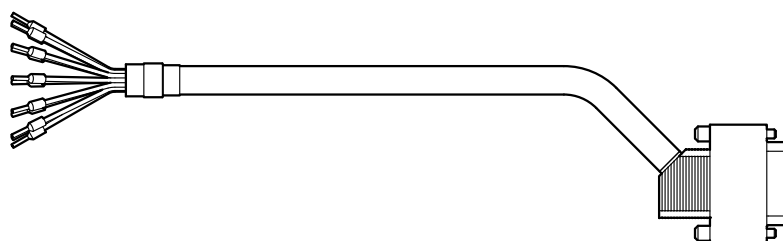

Motor series	Encoder type	Encoder cable	
		Installation	Part number
DT(E)/DV(E)//DR motors	ES1S, ES2S, EV1S, EV2S, EH1S, ES1R, ES2R, EV1R, EV2R, EH1R		1332 459 4
			1332 458 6



- Part number: 188 180 9
- Cable (option DWE12B, interface adapter HTL → TTL) to connect push-pull HTL encoders at X15 of the DEH11B/21B option (→ chapter "DWE11B/12B interface adapter option").

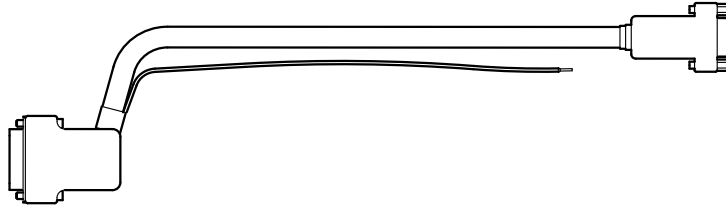

Type	Installation	Part number
DWE12B option (Connection of push-pull HTL encoders)		188 180 9

- Part number: 198 829 8 or 198 828 X
- Cable for push-pull HTL encoder connection with terminal box connection on motor end.

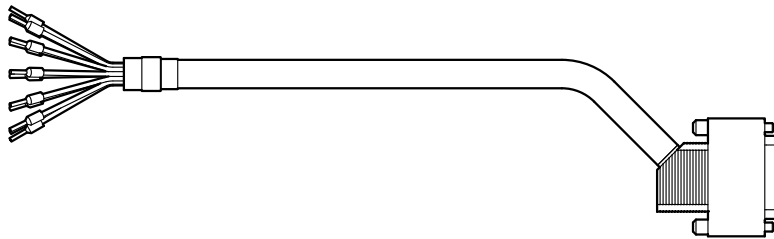

Type	Installation	Part number
Push-pull HTL encoders ES1C, ES2C, EV1C, EV2C, EH1C → DT(E)/DV(E)/DR motors		198 829 8
		198 828 X



Prefabricated Cables

Encoder cable for DT/DV/CMP, CM, (DS) motors on X15 DEH11B/DEH21B

- Part number: 198 829 8 or 198 828 X
- Cable to connect an external DC 5 V TTL encoder with terminal box connection on the motor end to the DC 5 V encoder power supply DWI11A.

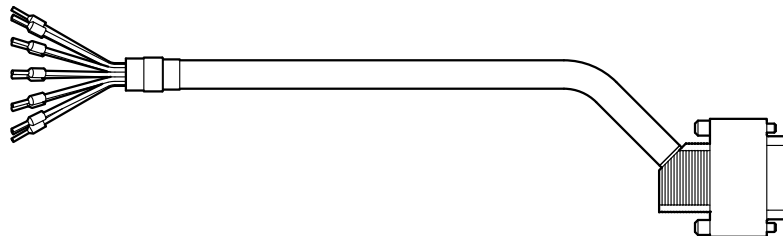

Type	Installation	Part number
DC 5 V TTL sensors ES1T, ES2T, EV1T, EV2T, EH1T → DWI11A X2		198 829 8
		198 828 X

- Part number: 817 957 3
- Cable to connect the DC 5 V encoder power supply type DWI11A via plug connector.

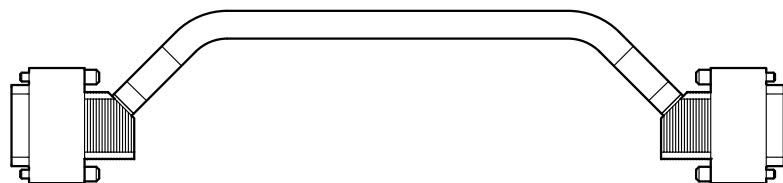

Type	Installation	Part number
DEH11B/21B X15 → DWI11A X1		817 957 3



- Part number: 1332 813 1 or 1332 812 3
- Y cable to connect the AV1Y absolute encoder with plug connector on the motor side. The following encoder tracks are evaluated with the Y cable:
 - SSI track of the AV1Y absolute encoder and at DIP11B/DEH21B X62
 - sin/cos track of the AV1Y absolute encoder at DEH11B X15

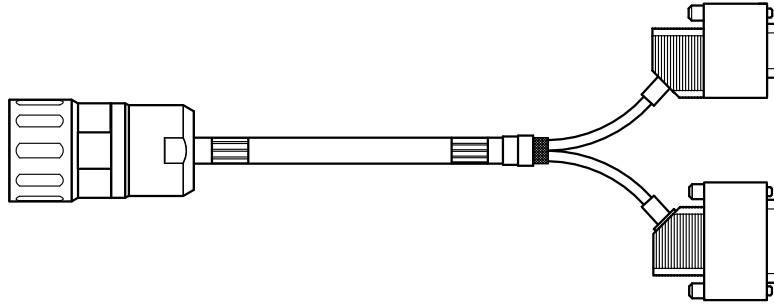

Type	Installation	Part number
DEH11B X15 → AV1Y and DIP11B/DEH21B X62		1332 813 1
		1332 812 3

- Part number: 593 968 2
- Extension cable to connect the AV1Y absolute encoder with plug connector on the motor end.

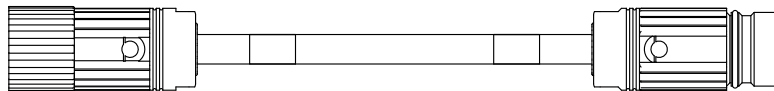

Type	Installation	Part number
DT(E)/DV(E)/DR motors → AV1Y		593 968 2



Prefabricated Cables

Encoder cable for distance encoders on X14, DEH11B / DER11B / DEU21B

7.11 Encoder cable for distance encoders on X14, DEH11B / DER11B / DEU21B

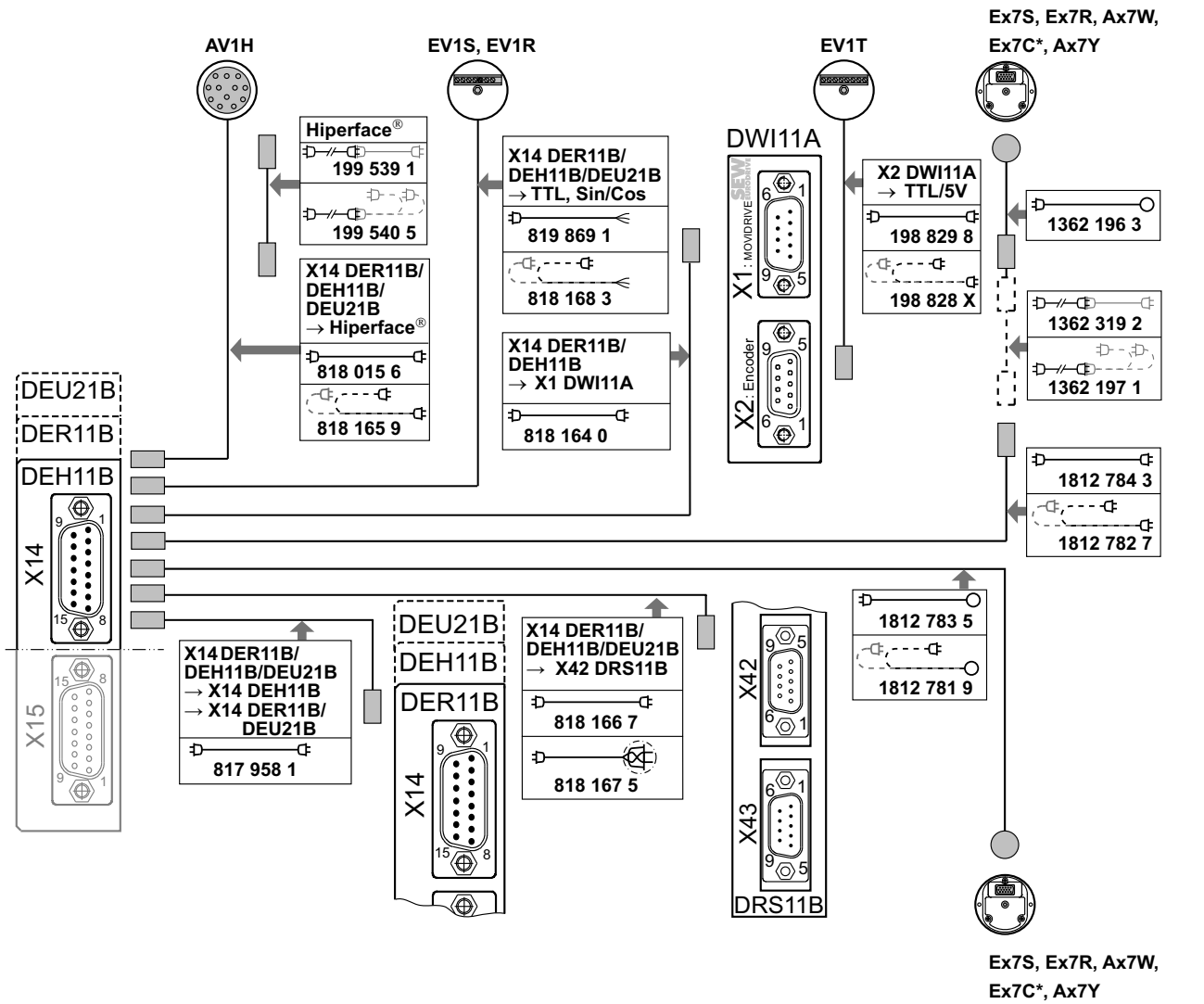

1474945803



INFORMATION

* ES7C and EG7C may only be used in connection with the DEU21B multi-encoder card. For the individual wiring diagrams, refer to the section "Installation" in the MOVIDRIVE® MDX60B/61B operating instructions.



- Part number: 818 015 6 or 818 165 9
- Cable to connect external encoders via plug connectors.

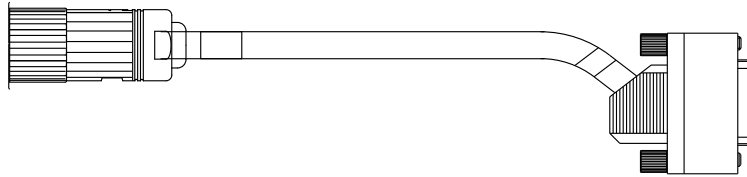

- Part number: 199 539 1 or 199 540 5
- Extension cable to connect external encoders via plug connectors.

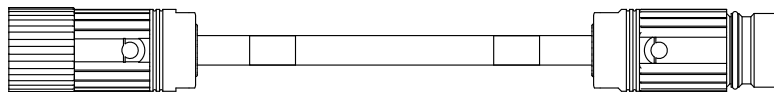

Type	Installation	Part number
DEH11B / DER11B / DEU21B X14 → AV1H, AS1H, ES1H, AF1H, EF1H		818 015 6
		818 165 9
		199 539 1
		199 540 5

- Part number: 819 869 1 or 818 168 3
- Cable to connect external encoders via encoder terminal strip.

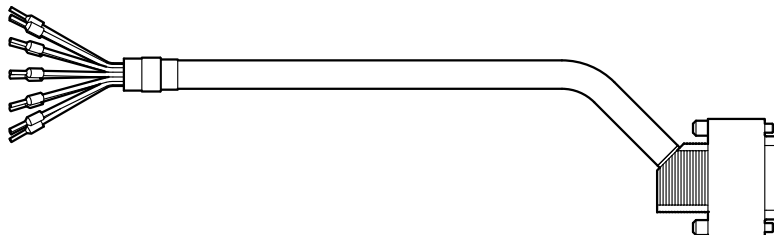

Type	Installation	Part number
DEH11B / DER11B / DEU21 B X14 → sin/cos encoder		819 869 1
		818 168 3



Prefabricated Cables

Encoder cable for distance encoders on X14, DEH11B / DER11B / DEU21B

- Part number: 818 164 0
- Cable to connect the DC 5 V encoder power supply type DWI11A via plug connector.

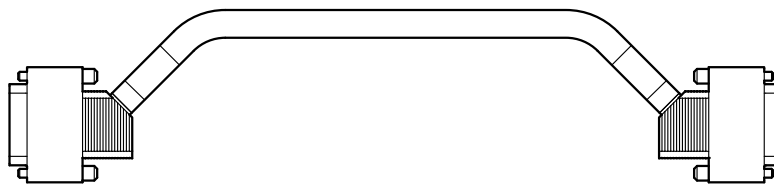

Type	Installation	Part number
DEH11B / DER11B / DEU21 B X14 → DWI11A X1		818 164 0

- Part number: 198 829 8 or 198 828 X
- Cable to connect an external DC 5 V TTL sensor to the DC 5 V encoder power supply type DWI11A via encoder terminal strip.

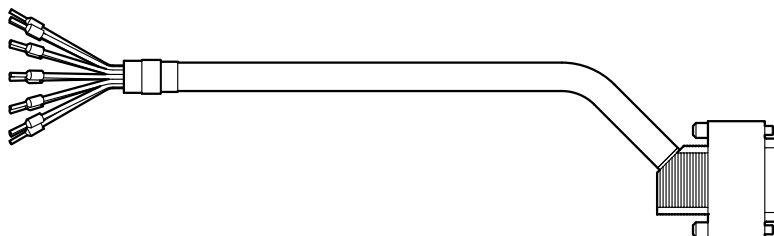

Type	Installation	Part number
DC 5 V TTL sensor → DWI11A X2		198 829 8
		198 828 X

- Part number: 817 958 1
- Cable to connect a master/slave connection.

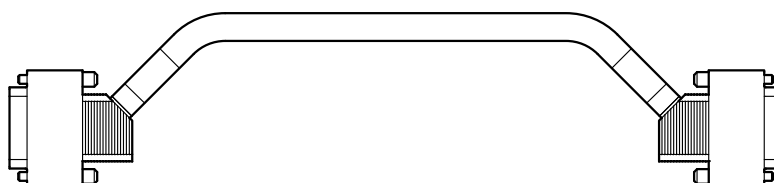

Type	Installation	Part number
DEH11B / DER11B / DEU21B X14 → DEH11B / DER11B / DEU21B X14		817 958 1



- Part number: 0818 166 7 or 0818 167 5
- Cable to connect the encoder simulation (DEH11B/DER11B:X14) of the master to terminal X42 of option DRS11B.

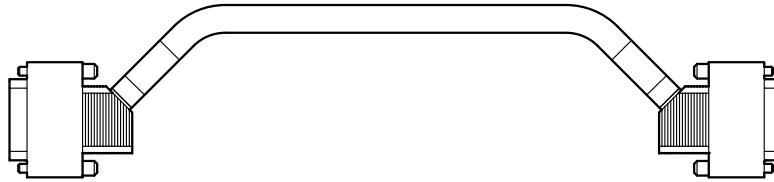

Type	Installation	Part number
DEH11B / DER11B / DEU21B X14 → DRS11B X42 (master and slave turn in the same direction)		0818 166 7
DEH11B / DER11B / DEU21B X14 → DRS11B X42 (master and slave turn in opposite directions)		0818 167 5

- Part number: 1812 783 5 or 1812 781 9
- Cable with D-sub 15 plug connector and encoder connection cover:

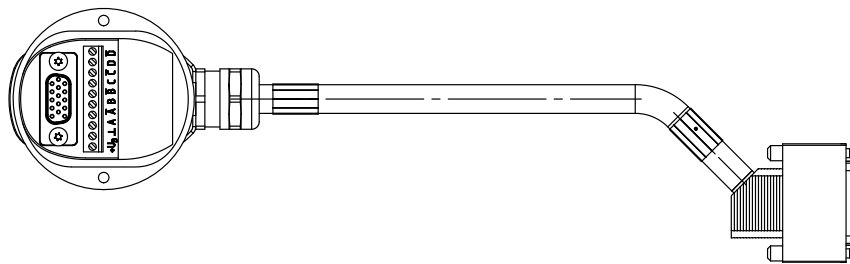

Encoder type	Encoder cable	
	Installation	Part number
ES7S, ES7R, ES7C, AS7W, AS7Y EG7S, EG7R, EG7C, AG7W, AG7Y,		1812 783 5
		1812 781 9



Prefabricated Cables

Encoder cable for distance encoders on X14, DEH11B / DER11B / DEU21B

- Part number: 1362 196 3
- Cable with encoder connection cover and M23 plug connector:

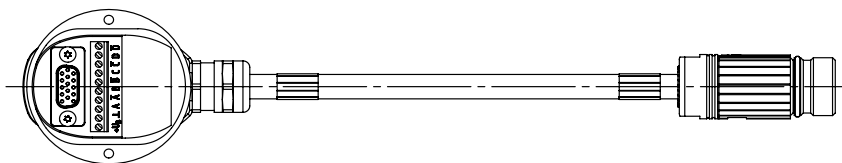

- Part number: 1362 319 2 or 1362 197 1
- Optional: Extension cable with M23 plug connector on both sides:

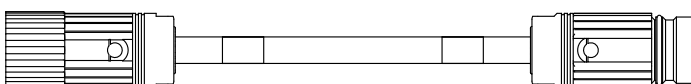

- Part number: 1812 784 3 or 1812 782 7
- Cable with M23 plug connector and D-sub 15 plug connector:

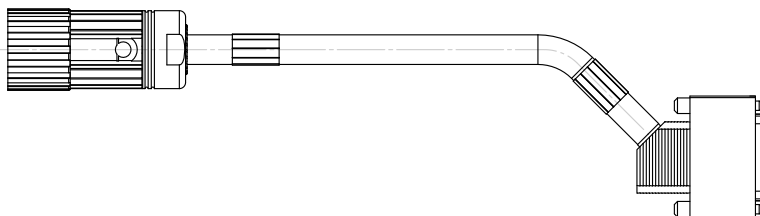

Encoder type	Encoder cable	
	Installation	Part number
ES7S, ES7R, ES7C, AS7W, AS7Y, EG7S, EG7R, EG7C, AG7W, AG7Y		1362 196 3
		1362 319 2
		1362 197 1
		1812 784 3
		1812 782 7



7.12 Encoder cable for resolvers on X15 DER11B

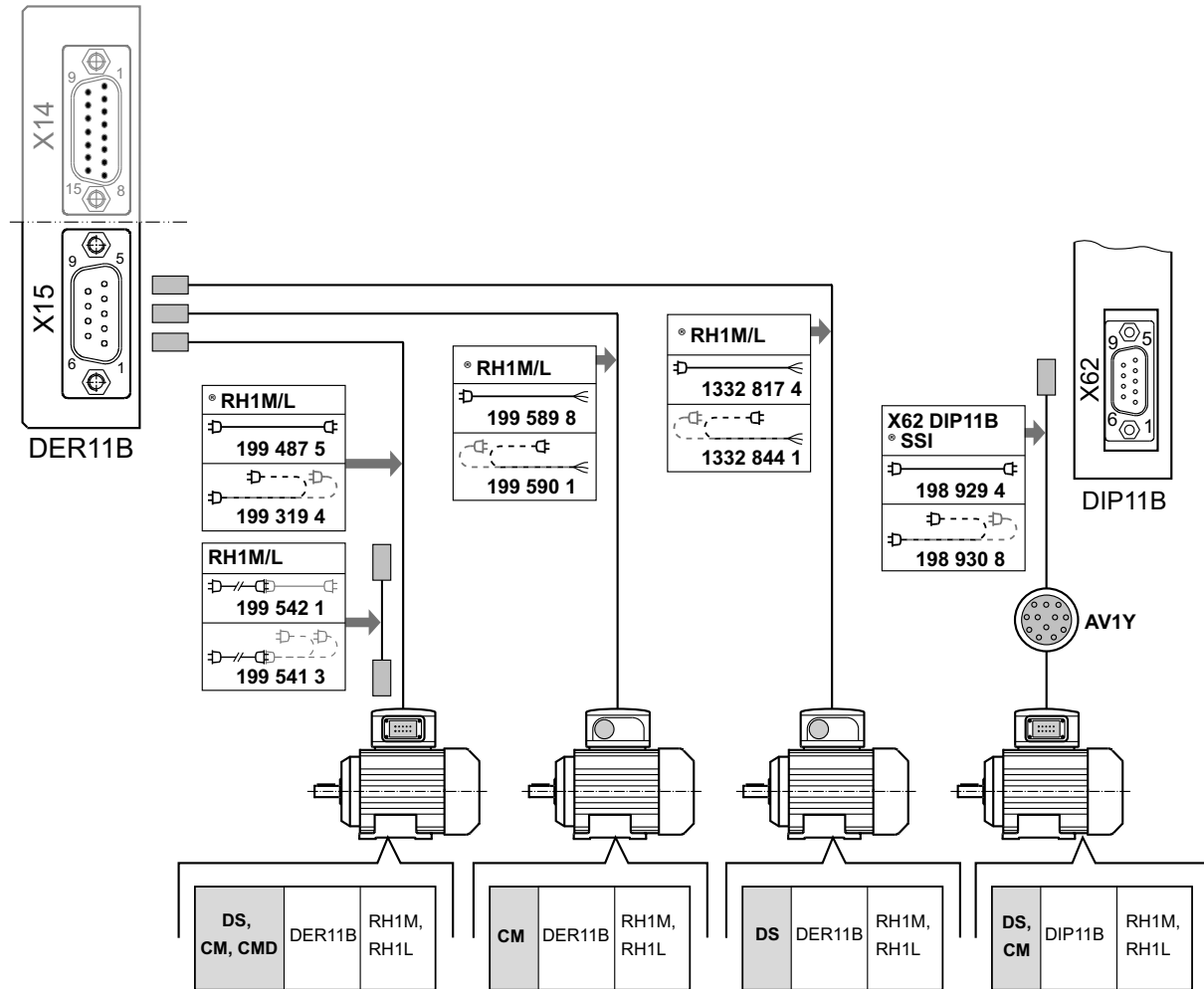

1474953611

For the individual wiring diagrams, refer to the section "Installation" in the MOVIDRIVE® MDX60B/61B operating instructions.



Prefabricated Cables

Encoder cable for resolvers on X15 DER11B

- Part number: 199 487 5 or 199 319 4
- Cable to connect resolvers RH1M / RH1L with plug connector connection on the motor side to DS, CM, CMD or CMP motors.

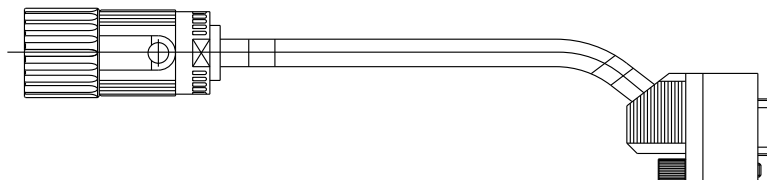

- Part number: 199 542 1 or 199 541 3
- Extension cable to connect resolvers RH1M / RH1L with plug connector connection on the motor side to DS, CM, CMD or CMP motors.

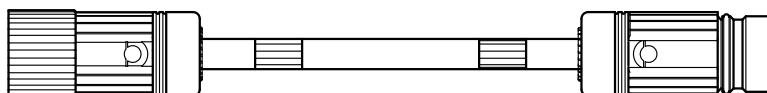

Type	Installation	Part number
DER11B X15 → DS/CM/CMD/CMP motors with RH1M/RH1L		199 487 5
		199 319 4
		199 542 1
		199 541 3



- Part numbers:
 - For CM motors: 199 589 8 or 199 590 1
 - For DS motors: 1332 817 4 or 1332 844 1
- Cable to connect resolvers RH1M / RH1L with terminal box connection on the motor side to CM and DS motors.

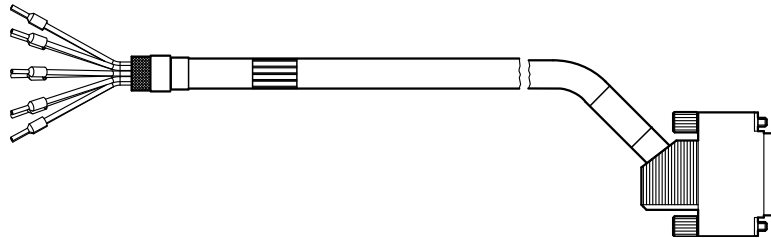

Type	Installation	Part number
DER11B X15 → CM motors with RH1M/RH1L		199 589 8
		199 590 1
DER11B X15 → DS motors with RH1M/RH1L		1332 817 4
		1332 844 1

- Part number: 198 929 4 or 198 930 8
- CM and DS motors with integrated resolver: Additional cable to connect the AV1Y absolute encoder with plug connector connection on the motor side to DIP11B X62.



Type	Installation	Part number
DS/CM motors with AV1Y → DIP11B X62		198 929 4
		198 930 8



8 Motor Selection

8.1 Basic recommendations for motor selection

- Only use motors with at least thermal class 155 (F).
- Use TF thermistors or TH winding thermostats. TH should be preferred in the case of group drives on one inverter. The series connection of the TH contacts (normally closed) is not subject to limitation when both monitoring functions are used.
- For group drives, we recommend that the motors should not differ from one another by more than 3 motor types.
- Use 4-pole motors if possible. This recommendation applies particularly to gearmotors operated with a high oil filling level due to their vertical mounting position.
- Generally speaking, the motor can be operated at its listed power without forced cooling if the operating conditions differ from S1 operation, e.g. positioning drive with 1:20 speed range in S3 operation.
- Do not select a motor that is too big, particularly for delta connection. Otherwise, the inverter may trigger a short circuit fault.
- A MOVIDRIVE® MDX61B with DEH11B Hiperface® encoder card option or with DER11B resolver card option is required for speed control. In this case, the motor must be equipped with an encoder (Hiperface®, sin/cos, or TTL) or resolver.

8.2 Motor selection for asynchronous AC motors (VFC)

8.2.1 Voltage/frequency characteristic curve

The VFC operating mode runs the asynchronous motor on a load-dependent voltage/frequency curve. The continuous calculation of the motor model enables the full motor torque to be utilized right down to the lowest speeds. This characteristic curve is set by entering the rated motor voltage and the rated motor frequency in the startup function. The setting determines the speed-dependent torque and power characteristics of the asynchronous motor.

The following figure shows an example of the voltage/frequency characteristic curves of an asynchronous AC motor 230/400 V, 50 Hz.

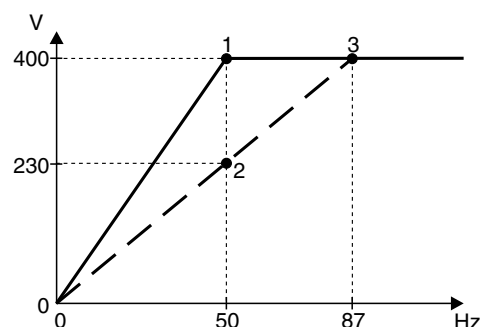

1475722635

1 Star connection; 400 V, 50 Hz

2 Delta connection: 230 V, 50 Hz

3 Delta connection: 400 V, 87 Hz



The inverter output voltage V_{out} is limited by the connected line voltage. The "nominal line voltage" input value in the startup function limits the effective value of the maximum output voltage. This restriction is used whenever the connected motor has a lower rated voltage than the power supply of the inverter. Enter the maximum permitted motor voltage. Furthermore, make sure that the "nominal line voltage" input value is less than or equal to the supply voltage of the inverter.

8.2.2 Speed/torque characteristic curve

The field weakening range starts when the set maximum output voltage of the inverter is reached. Consequently, the speed range of the motor is divided into two ranges:

- Basic speed range → constant torque with increasing power
- Field weakening range → constant power with an inversely proportionate decrease in torque.

When determining the maximum speed in the field weakening range, note that the nominal torque M_N (in relation to the nominal speed, e.g. $n_N = 1500$ rpm) falls in inverse proportion and the breakdown torque M_K is reduced in an inverse quadratic relationship. The M_K/M_N ratio is a motor-specific parameter. The MOVIDRIVE® stall protection limits the speed when the maximum possible torque is reached.

The following figure shows an example of different motor characteristic curves in the basic speed range and in the field weakening range.

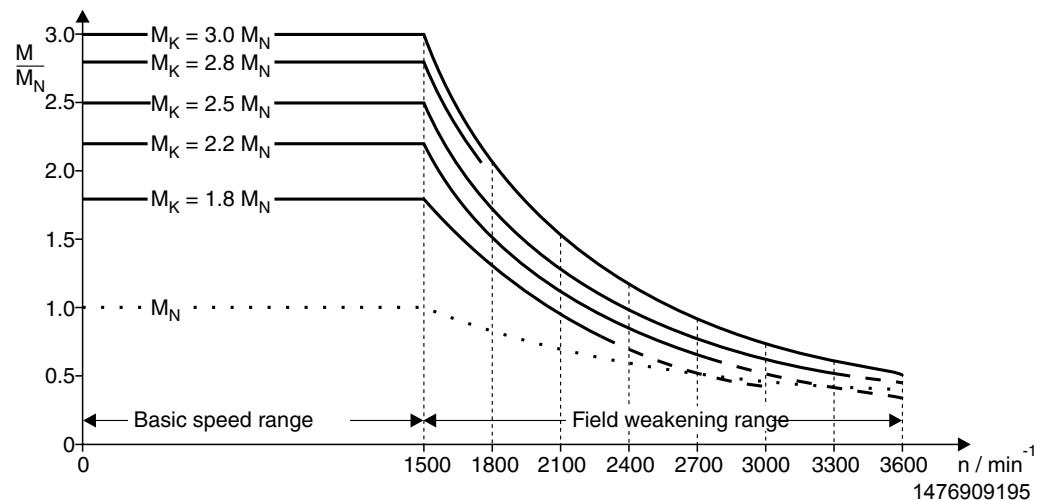

With gearmotors, the maximum motor speed depends on the size and mounting position of the gear unit. The speed should not exceed 3000 rpm due to the resulting noise and oil churning losses.



Motor Selection

Motor selection for asynchronous AC motors (VFC)

Typical speed-torque characteristic curve

M_N is determined by the motor. M_{max} and n_{base} depend on the motor/inverter combination. Refer to the motor selection tables for the CFC mode for the values of n_{base} , M_N and M_{max} .

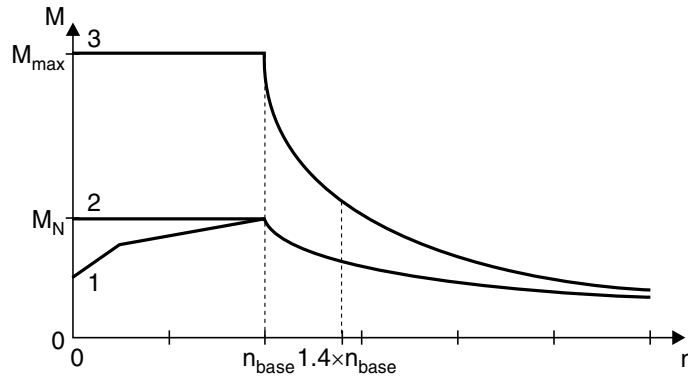

1476913547

- [1] With self-cooling
- [2] With forced cooling
- [3] Maximum torque

8.2.3 Dynamic applications ($P_{inverter} > P_{motor}$)

Observe the following notes for dynamic applications in which the inverter power is significantly greater than the motor power:

- The startup function sets the current limit of the inverter (P303/P313) to 150 % of the rated motor current. The value of the current limit is based on the rated inverter current. As a result, 150 % of the rated motor current is less than 150 % of the rated inverter current (value of P303/P313). For dynamic applications, this parameter must be manually set to a higher value.
- The startup function sets the slip compensation parameter (P324/P334) to the rated slip of the motor. In the case of VFC-n-CONTROL, the internal slip limiting function allows the slip to reach max. 150 % of this setting. Consequently, the motor develops at most 150 % of the rated motor torque. For higher torque ratings, the slip compensation parameter (P324) must be increased accordingly.



INFORMATION

Set parameter P324 "Slip compensation" to **max. 130% of the rated slip of the motor for stable operation.**

Combinations with
 $P_{inverter} >$
 $4 \times P_{motor}$

For inverter/motor combinations in which the inverter power is greater than four times the motor power, special measures must be taken during project planning and startup. The reason for this is the large difference between the rated inverter current and the rated motor current.

Therefore, note the following measures:

- Perform project planning for connecting the motor in a delta connection. This increases the motor current by a factor of $\sqrt{3}$ and lowers the unfavorable ratio.
- If this measure does not suffice, start up the motor in VFC & GROUP or V/f operating mode. In these operating modes, the inverter simulates a supply system with constant voltage and frequency with a constant V/f ratio.



8.2.4 DRS motor selection with delta/star connection type (AC 230/400 V / 50 Hz)

Motors for AC 380 V / 60 Hz can also be allocated on the basis of this selection table. P _{max} in kW (HP) for operation on MOVIDRIVE® MDX60/61B...-5_3 (AC 400/500 V units)							
Connection		△ / AC 400 V ¹⁾			△ / AC 230 V ²⁾		
Cooling		Self-cooling		Forced cooling		Self-cooling	Forced cooling
f _{min} - f _{max}	Hz	10 - 50 / 6 - 60 5 - 70 / 5.5 - 80		≤ 2.5 - 50 / ≤ 3 - 60 ³⁾		9 - 87	≤ 2.5 - 87 ³⁾
n _{min} - n _{max}	rpm	300 - 1500 / 180 - 1800 150 - 2100 / 165 - 2400		≤ 75 - 1500 / ≤ 90 - 1800		270 - 2610	≤ 75 - 2610
Setting range		1:5 / 1:10 / 1:15			≥ 1:20		
Motor type	Rated power P _n kW (HP)	P = P _{reduced} kW (HP) MDX ⁴⁾ 60/61B...-5_3		P = P _n kW (HP) MDX ⁴⁾ 60/61B...-5_3		P = P _{increased} kW (HP) MDX ⁴⁾ 60/61B...-5_3	
DRS71S4	0.37 (0.5)	0.25 (0.34)	0005/0015	0.37 (0.5)	0005/0015	0.55 (0.74)	0005/0015
DRS71M4	0.55 (0.74)	0.37 (0.5)		0.55 (0.74)		0.75 (1.0)	0008/0015
DRS80S4	0.75 (1.0)	0.55 (0.74)	0008/0015	0.75 (1.0)	0011/0015	1.1 (1.5)	0011/0015
DRS80M4	1.1 (1.5)	0.75 (1.0)		1.1 (1.5)		1.5 (2.0)	0014/0015
DRS90M4	1.5 (2.0)	1.1 (1.5)	0011/0015	1.5 (2.0)	0014/0015	2.2 (3.0)	0022
DRS90L4	2.2 (3.0)	1.5 (2.0)	0014/0015	2.2 (3.0)	0022	3.0 (4.0)	0030
DRS100M4	3.0 (4.0)	2.2 (3.0)	0022	3.0 (4.0)	0030	4.0 (5.4)	0040
DRS100LC4	4.0 (5.4)	3.0 (4.0)	0030	4.0 (5.4)	0040	5.5 (7.4)	0055
DRS112M4							
DRS132S4	5.5 (7.4)	4.0 (5.4)	0040	5.5 (7.4)	0055	7.5 (10)	0075
DRS132M4	7.5 (10)	5.5 (7.4)	0055	7.5 (10)	0075	9.2 (12)	0110
DRS132MC4	9.2 (12)	7.5 (10)	0075	9.2 (12)	0110	11 (15)	
DRS160S4						15 (20)	0150
DRS160M4	11 (15)	9.2 (12)	0110	11 (15)	0150	15 (20)	0150
DRS160MC4	15 (20)	11 (15)		15 (20)		18.5 (24.8)	0220
DRS180S4 ⁵⁾			18.5 (24.8)	0150	18.5 (24.8)	22 (30)	
DRS180M4 ⁵⁾	22 (30)	18.5 (24.8)	0220	22 (30)	0220	30 (40)	0300
DRS180L4 ⁵⁾	30 (40)	22 (30)		30 (40)		37 (50)	0300
DRS180LC4 ⁵⁾			37 (50)	30 (40)	0300	37 (50)	
DRS225S4 ⁶⁾	45 (60)	37 (50)	0370	45 (60)	0450	55 (74)	0550
DRS225M4 ⁶⁾	55 (74)	45 (60)	0450	55 (74)	0550	75 (100)	0750
DRS225MC4 ⁶⁾	110 (148)	90 (120)	0900	110 (148)	1100	132 (177)	1320
DRS315K4 ⁷⁾							
DRS315S4 ⁷⁾	160 (215)	132 (177)	1320				
DRS315M4 ⁷⁾							

- 1) Also applies to motors with AC 460 V or AC 500 V nominal voltage and for AC 400/690 V motors in △ connection.
- 2) Also applies to motors with AC 266 V or AC 290 V nominal voltage.
- 3) Without speed control: f_{min} = 0,5 Hz
- 4) In each application, the units listed here permit intermittent loads of up to two times the rated load with size 0 (0005 ... 0014) and up to 1.5 times the rated load with sizes 1 ... 6 (0015 ... 1320). With variable torque load and constant load without overload, each inverter can also be operated with an increased continuous output power (→ MDX60B/61B catalog, Technical Data chapter). The continuous output current of 125 % of the rated unit current is only available at f_{PWM} = 4 kHz.
- 5) Maximum permitted motor speed n_{max} = 3400 rpm
- 6) Maximum permitted motor speed n_{max} = 3000 rpm
- 7) Maximum permitted motor speed n_{max} = 2600 rpm



Motor Selection

Motor selection for asynchronous AC motors (VFC)

8.2.5 DRE motor selection with delta/star connection type (AC 230/400 V / 50 Hz)

Motors for AC 380 V / 60 Hz can also be allocated on the basis of this selection table. P _{max} in kW (HP) for operation on MOVIDRIVE® MDX60/61B...-5_3 (AC 400/500 V units)							
Connection		Δ / AC 400 V ¹⁾			Δ / AC 230 V ²⁾		
Cooling		Self-cooling		Forced cooling		Self-cooling	Forced cooling
f _{min} - f _{max}	Hz	10 - 50 / 6 - 60 5 - 70 / 5.5 - 80		≤ 2.5 - 50 / ≤ 3 - 60 ³⁾		9 - 87	≤ 2.5 - 87 ³⁾
n _{min} - n _{max}	rpm	300 - 1500 / 180 - 1800 150 - 2100 / 165 - 2400		≤ 75 - 1500 / ≤ 90 - 1800		270 - 2610	≤ 75 - 2610
Setting range		1:5 / 1:10 / 1:15		≥ 1:20		1:10	≥ 1:20
Motor type	Rated power P _n kW (HP)	P = P _{reduced}		P = P _n		P = P _{increased} ⁴⁾	
		kW (HP)	MDX ⁵⁾ 60/61B...-5_3	kW (HP)	MDX ⁴⁾ 60/61B...-5_3	kW (HP)	MDX ⁴⁾ 60/61B...-5_3
DRE80M4	0.75 (1.0)	0.55 (0.74)	0005/0015	0.75 (1.0)	0008/0015	1.1 (1.5)	0011/0015
DRE90M4	1.1 (1.5)	0.75 (1.0)	0008/0015	1.1 (1.5)	0011/0015	1.5 (2.0)	0014/0015
DRE90L4	1.5 (2.0)	1.1 (1.5)	0011/0015	1.5 (2.0)	0014/0015	2.2 (3.0)	0022
DRE100M4	2.2 (3.0)	1.5 (2.0)	0014/0015	2.2 (3.0)	0022	3.0 (4.0)	0030
DRE100LC4	3.0 (4.0)	2.2 (3.0)	0022	3.0 (4.0)	0030	4.0 (5.4)	0040
DRE112M4							
DRE132S4	4.0 (5.4)	3.0 (4.0)	0030	4.0 (5.4)	0040	5.5 (7.4)	0055
DRE132M4	5.5 (7.4)	4.0 (5.4)	0040	5.5 (7.4)	0055	7.5 (10)	0075
DRE132MC4	7.5 (10)	5.5 (7.4)	0055	7.5 (10)	0075	9.2 (12)	0110
DRE160S4							
DRE160M4	9.2 (12)	7.5 (10)	0075	9.2 (12)		11 (15)	
DRE160MC4	11 (15)	9.2 (12)	0110	11 (15)	0110	15 (20)	0150
DRE180S4 ⁶⁾							
DRE180M4 ⁵⁾	15 (20)	11 (15)		15 (20)	0150	18.5 (24.8)	0220
DRE180L4 ⁵⁾	18.5 (24.8)	15 (20)	0150	18.5 (24.8)		22 (30)	
DRE180LC4 ⁵⁾	22 (30)	18.5 (24.8)	0220	22 (30)	0220	30 (40)	0300
DRE200L4 ⁷⁾							
DRE225S4 ⁶⁾	30 (40)	22 (30)		30 (40)	0300	37 (50)	0370
DRE225M4 ⁶⁾	37 (50)	30 (40)	0300	37 (50)	0370	45 (60)	0450
DRE225MC4 ⁶⁾	45 (60)	37 (50)	0370	45 (60)	0450	55 (74)	0550
DRE315K4 ⁸⁾	110 (148)	90 (120)	0900	110 (148)	1100	132 (177)	1320
DRE315S4 ⁷⁾	132 (177)	110 (148)	1100	132 (177)	1320		
DRE315M4 ⁷⁾	160 (215)	132 (177)	1320				

- 1) Also applies to motors with AC 460 V or AC 500 V nominal voltage and for AC 400/690 V motors in Δ connection.
- 2) Also applies to motors with AC 266 V or AC 290 V nominal voltage.
- 3) Without speed control: f_{min} = 0.5 Hz
- 4) The motor is operated at the power of the next larger motor (one frame size), rather than with the $\sqrt{3}$ -fold power.
- 5) In each application, the units listed here permit intermittent loads of up to two times the rated load with size 0 (0005 ... 0014) and up to 1.5 times the rated load with sizes 1 ... 6 (0015 ... 1320). With variable torque load and constant load without overload, each inverter can also be operated with an increased continuous output power (→ MDX60B/61B catalog, Technical Data chapter). The continuous output current of 125 % of the rated unit current is only available at f_{PWM} = 4 kHz.
- 6) Maximum permitted motor speed n_{max} = 3400 rpm
- 7) Maximum permitted motor speed n_{max} = 3000 rpm
- 8) Maximum permitted motor speed n_{max} = 2600 rpm



8.2.6 DRP motor selection with delta/star connection type (AC 230/400 V / 50 Hz)

Motors for AC 380 V / 60 Hz can also be allocated on the basis of this selection table. P _{max} in kW (HP) for operation on MOVIDRIVE® MDX60/61B...-5_3 (AC 400/500 V units)							
Connection		△ / AC 400 V ¹⁾				△ / AC 230 V ²⁾	
Cooling		Self-cooling		Forced cooling		Self-cooling	Forced cooling
f _{min} - f _{max}	Hz	10 - 50 / 6 - 60 5 - 70 / 5.5 - 80		≤ 2.5 - 50 / ≤ 3 - 60 ³⁾		9 - 87	≤ 2.5 - 87 ³⁾
n _{min} - n _{max}	rpm	300 - 1500 / 180 - 1800 150 - 2100 / 165 - 2400		≤ 75 - 1500 / ≤ 90 - 1800		270 - 2610	≤ 75 - 2610
Setting range		1:5 / 1:10 / 1:15		≥ 1:20		1:10	≥ 1:20
Motor type	Rated power P _n kW (HP)	P = P _{reduced} kW (HP) MDX ⁵⁾ 60/61B...-5_3		P = P _n kW (HP) MDX ⁴⁾ 60/61B...-5_3		P = P _{increased} ⁴⁾ kW (HP) MDX ⁴⁾ 60/61B...-5_3	
DRP90M4	0.75 (1.0)	0.55 (0.74)	0005/0015	0.75 (1.0)	0008/0015	1.1 (1.5)	0011/0015
DRP90L4	1.1 (1.5)	0.75 (1.0)	0008/0015	1.1 (1.5)	0011/0015	1.5 (2.0)	0014/0015
DRP100M4	1.5 (2.0)	1.1 (1.5)	0011/0015	1.5 (2.0)	0014/0015	2.2 (3.0)	0022
DRP100L4	2.2 (3.0)	1.5 (2.0)	0014/0015	2.2 (3.0)	0022	3.0 (4.0)	0030
DRP112M4	3.0 (4.0)	2.2 (3.0)	0022	3.0 (4.0)	0030	4.0 (5.4)	0040
DRP132M4	4.0 (5.4)	3.0 (4.0)	0030	4.0 (5.4)	0040	5.5 (7.4)	0055
DRP132MC4	5.5 (7.4)	4.0 (5.4)	0040	5.5 (7.4)	0055	7.5 (10)	0075
DRP160S4						9.2 (12)	
DRP160M4	7.5 (10)	5.5 (7.4)	0055	7.5 (10)	0075	11 (15)	0110
DRP160MC4	9.2 (12)	7.5 (10)	0075	9.2 (12)	0110	15 (20)	
DRP180S4 ⁶⁾						18.5 (24.8)	
DRP180M4 ⁵⁾	11 (15)	9.2 (12)	0110	11 (15)	0150	18.5 (24.8)	0150
DRP180L4 ⁵⁾	15 (20)	11 (15)		15 (20)			
DRP180LC4 ⁵⁾	18.5 (24.8)	15 (20)	0150	18.5 (24.8)	0220	22 (30)	0220
DRP200L4 ⁷⁾						30 (40)	
DRP225S4 ⁶⁾	22 (30)	18.5 (24.8)	0220	22 (30)	0300	37 (50)	0370
DRP225M4 ⁶⁾	30 (40)	22 (30)		30 (40)			
DRP225MC4 ⁶⁾	37 (50)	30 (40)	0300	37 (50)	0370	45 (60)	0450
DRP315K4 ⁸⁾	90 (120)	75 (100)	0750	90 (120)	0900	110 (148)	1100
DRP315S4 ⁷⁾	110 (148)	90 (120)	0900	110 (148)	1100	132 (177)	1320
DRP315M4 ⁷⁾	132 (177)	110 (148)	1100	132 (177)	1320		
DRP315L4 ⁷⁾	160 (215)	132 (177)	1320				

- 1) Also applies to motors with AC 460 V or AC 500 V nominal voltage and for AC 400/690 V motors in △ connection.
- 2) Also applies to motors with AC 266 V or AC 290 V nominal voltage.
- 3) Without speed control: f_{min} = 0.5 Hz
- 4) The motor is operated at the power of the next larger motor (one frame size), rather than with the √3-fold power.
- 5) In each application, the units listed here permit intermittent loads of up to two times the rated load with size 0 (0005 ... 0014) and up to 1.5 times the rated load with sizes 1 ... 6 (0015 ... 1320). With variable torque load and constant load without overload, each inverter can also be operated with an increased continuous output power (→ MDX60B/61B catalog, Technical Data chapter). The continuous output current of 125 % of the rated unit current is only available at f_{PWM} = 4 kHz.
- 6) Maximum permitted motor speed n_{max} = 3400 rpm
- 7) Maximum permitted motor speed n_{max} = 3000 rpm
- 8) Maximum permitted motor speed n_{max} = 2600 rpm



Motor Selection

Motor selection for asynchronous AC motors (VFC)

8.2.7 DR63, DV250, DV280 motor selection with delta/star connection type (AC 230/400 V / 50 Hz)

Motors for AC 380 V / 60 Hz can also be allocated on the basis of this selection table.				
P_{max} in kW (HP) for operation on MOVIDRIVE® MDX60/61B...-5_3 (AC 400/500 V units)				
Connection	\sphericalangle / AC 400 V ¹⁾		\triangle / AC 230 V ²⁾	
Cooling	Self-cooling	Forced cooling	Self-cooling	Forced cooling
$f_{min} - f_{max}$ Hz	10 - 50 / 6 - 60 5 - 70 / 5.5 - 80	$\leq 2.5 - 50 / \leq 3 - 60^3)$	9 - 87	$\leq 2.5 - 87^3)$
$n_{min} - n_{max}$ rpm	300 - 1500 / 180 - 1800 150 - 2100 / 165 - 2400	$\leq 75 - 1500 / \leq 90 - 1800$	270 - 2610	$\leq 75 - 2610$
Setting range	1:5 / 1:10 / 1:15	$\geq 1:20$	1:10	$\geq 1:20$
Motor type ⁴⁾	Rated power P_n kW (HP)	$P = P_{reduced}$ kW (HP) MDX ⁶⁾ 60/61B...-5_3	$P = P_n$ kW (HP) MDX ⁴⁾ 60/61B...-5_3	$P = P_{increased}$ ⁵⁾ kW (HP) MDX ⁴⁾ 60/61B...-5_3
DR63S4	0.12 (0.16)			0.18
DR63M4	0.18 (0.24)		0.18	0.25
DR63L4	0.25 (0.34)	0.18 (0.24) 0005	0.25 (0.34) 0005	0.37 (0.5)
DV250M4	55 (74)	45 (60) 0450	55 (74) 0550	75 (100) 0750
DV280S4	75 (100)	55 (74) 0550	75 (100) 0750	90 (120) 0900
D280M4	90 (120)	75 (100) 0750	90 (120) 0900	110 (148) 1100

- 1) Also applies to motors with AC 460 V or AC 500 V nominal voltage and for AC 400/690 V motors in \triangle connection.
- 2) Also applies to motors with AC 266 V or AC 290 V nominal voltage.
- 3) Without speed control: $f_{min} = 0.5$ Hz
- 4) In load type S3 (40 % cdf), the motor may be operated at its listed power ($P = P_n$) even without forced cooling. Example: $P_{stat} = 2$ kW, $P_{dyn} = 2.5$ kW \rightarrow selected motor DV100M4 ($P_n = 2.2$ kW).
- 5) $P_{increased}$ means that the motor is operated at the power of the next larger motor (one frame size), rather than with the $\sqrt{3}$ -fold power.
- 6) In each application, the units listed here permit intermittent loads of up to two times the rated load with size 0 (0005 ... 0014) and up to 1.5 times the rated load with sizes 1 ... 6 (0015 ... 1320). With variable torque load and constant load without overload, each inverter can also be operated with an increased continuous output power (\rightarrow chapter Technical Data). The continuous output current of 125% of the rated unit current is only available at $f_{PWM} = 4$ kHz.



8.2.8 Examples for motor selection delta/star AC 230/400 V

Trolley drive

- $P_{\text{travel}} = 1.3 \text{ kW}$
- $P_{\text{max}} = 13 \text{ kW}$
- $n_{\text{min}} = 270 \text{ rpm}$, setting range 1:10
- $n_{\text{max}} = 2610 \text{ rpm}$

In inverter mode with adapted power ($P = P_n$), the motor can output 150 % of its listed power during the acceleration phase. This means:

$$P_{\text{Mot}} = P_{\text{max}} : 1.5 = 13 \text{ kW} : 1.5 = 8.67 \text{ kW}$$

A DRS132M4 motor with delta connection ($P_n = 9.2 \text{ kW}$) is selected.

The selection table allocates a MOVIDRIVE® MDX61B0055 ($P = P_n$).

Hoist drive

High constant load with short-term overload (acceleration):

- $P_{\text{max}} = 26 \text{ kW}$
- $P_{\text{const.}} = 20 \text{ kW}$
- Setting range 1:15, low speed only for positioning
- Brake applied when the drive is at a standstill
- Load type S3 (40 % c.d.f.)

The inverter can yield 150% of its nominal current during acceleration. Consequently, a MOVIDRIVE® MDX61B0220 is selected.

In view of the duty type (S3, 40 % cdf), the selection table allocates motor type DRS180L4 ($P_n = 22 \text{ kW}$) in a star connection.

For more information, refer to the "Project planning for hoists" chapter

Fan/pump

Variable torque load with the following power values:

- $P_{\text{max}} = 4.8 \text{ kW}$
- $n_{\text{max}} = 1400 \text{ rpm}$, continuous duty with n_{max}

The motor can be operated at its listed power ($P = P_n$) even without forced cooling due to the quadratically falling torque. Therefore, the motor type DRS132S4 in star connection ($P_n = 5.5 \text{ kW}$) is sufficient.

The selection table allocates a MOVIDRIVE® MDX61B0055 ($P = P_n$). However, as there is a variable torque load without overload, the inverter can be operated with increased output power. Consequently, a MOVIDRIVE® MDX61B0040 is sufficient.



Motor Selection

Motor selection for asynchronous AC motors (VFC)

8.2.9 DRS motor selection in delta connection type (AC 230 V / 50 Hz)

P _{max} kW (HP) for operation on MOVIDRIVE® MDX61B...-2_3 (AC 230 V units)					
Connection		△ / AC 230 V			
Cooling		Self-cooling		Forced cooling	
f _{min} - f _{max}	Hz	10 - 50 6 - 60 5 - 70 / 5.5 - 80		≤ 2.5 - 50 / ≤ 3 - 60 ¹⁾	
n _{min} - n _{max}	rpm	300 - 1500 180 - 1800 150 - 2100 / 165 - 2400		≤ 75 - 1500 / ≤ 90 - 1800	
Setting range		1:5 1:10 1:15		≥ 1:20	
Motor type	Rated power P _n kW (HP)	P = P _{reduced} kW (HP) With MDX61B...-2_3 ²⁾		P = P _n kW (HP) With MDX61B...-2_3	
DRS71S4	0.37 (0.5)	0.25 (0.34)	0015	0.37 (0.5)	0015
DRS71M4	0.55 (0.74)	0.37 (0.5)		0.55 (0.74)	
DRS80S4	0.75 (1.0)	0.55 (0.74)		0.75 (1.0)	
DRS80M4	1.1 (1.5)	0.75 (1.0)		1.1 (1.5)	
DRS90M4	1.5 (2.0)	1.1 (1.5)		1.5 (2.0)	
DRS90L4	2.2 (3.0)	1.5 (2.0)		2.2 (3.0)	
DRS100M4	3.0 (4.0)	2.2 (3.0)	0022	3.0 (4.0)	0037
DRS100LC4	4.0 (5.4)	3.0 (4.0)	0037	4.0 (5.4)	0055
DRS112M4					
DRS132S4	5.5 (7.4)	4.0 (5.4)	0055	5.5 (7.4)	0075
DRS132M4	7.5 (10)	5.5 (7.4)		7.5 (10)	
DRS132MC4	9.2 (12)	7.5 (10)	0075	9.2 (12)	0110
DRS160S4					
DRS160M4	11 (15)	9.2 (12)	0110	11 (15)	0150
DRS160MC4	15 (20)	11 (15)		0150	
DRS180S4					
DRS180M4	18.5 (24.8)	15 (20)	0150	18.5 (24.8)	0220
DRS180L4	22 (30)	18.5 (24.8)		22 (30)	
DRS180LC4	30 (40)	22 (30)	0220	30 (40)	0300
DRS200L4					
DRS225S4	37 (50)	30 (40)	0300	-	-

1) Without speed control: f_{min} = 0.5 Hz

2) The units listed here permit intermittent loads of up to 1.5 times the rated load in the specific application. With variable torque load and constant load without overload, each inverter can also be operated with an increased continuous output power (→ MDX60B/61B catalog, Technical Data chapter). The continuous output current of 125 % of the rated unit current is only available at f_{PWM} = 4 kHz.



8.2.10 DRE motor selection in delta connection type (AC 230 V / 50 Hz)

P_{max} kW (HP) for operation on MOVIDRIVE® MDX61B...-2_3 (AC 230 V units)					
Connection		△ / AC 230 V			
Cooling		Self-cooling		Forced cooling	
f_{min} - f_{max}	Hz	10 - 50		≤ 2.5 - 50 / ≤ 3 - 60 ¹⁾	
		6 - 60			
		5 - 70 / 5.5 - 80			
n_{min} - n_{max}	rpm	300 - 1500		≤ 75 - 1500 / ≤ 90 - 1800	
		180 - 1800			
		150 - 2100 / 165 - 2400			
Setting range		1:5		≥ 1:20	
		1:10			
		1:15			
Motor type	Rated power P_n kW (HP)	P = P_{reduced} kW (HP) With MDX61B...-2_3²⁾		P = P_n kW (HP) With MDX61B...-2_3³⁾	
DRE80M4	0.75 (1.0)	0.55 (0.74)	0015	0.75 (1.0)	0015
DRE90M4	1.1 (1.5)	0.75 (1.0)		1.1 (1.5)	
DRE90L4	1.5 (2.0)	1.1 (1.5)		1.5 (2.0)	
DRE100M4	2.2 (3.0)	1.5 (2.0)		2.2 (3.0)	
DRE100LC4	3.0 (4.0)	2.2 (3.0)	0022	3.0 (4.0)	0037
DRE112M4			0022		0037
DRE132S4	4.0 (5.4)	3.0 (4.0)	0037	4.0 (5.4)	0055
DRE132M4	5.5 (7.4)	4.0 (5.4)	0055	5.5 (7.4)	
DRE132MC4	7.5 (10)	5.5 (7.4)		0055	7.5 (10)
DRE160S4			0075		0110
DRE160M4	9.2 (12)	7.5 (10)	0075	9.2 (12)	
DRE160MC4	11 (15)	9.2 (12)	0110	11 (15)	
DRE180S4				0150	
DRE180M4	15 (20)	11 (15)	0150	15 (20)	0150
DRE180L4	18.5 (24.8)	15 (20)		0150	18.5 (24.8)
DRE180LC4	22 (30)	18.5 (24.8)	0220	22 (30)	
DRE200L4				0300	
DRE225S4	30 (40)	22 (30)	0300	30 (40)	0300
DRE225M4	37 (50)	30 (40)		-	

1) Without speed control: f_{min} = 0.5 Hz

2) The units listed here permit intermittent loads of up to 1.5 times the rated load in the specific application. With variable torque load and constant load without overload, each inverter can also be operated with an increased continuous output power (→ MDX60B/61B catalog, Technical Data chapter). The continuous output current of 125 % of the rated unit current is only available at f_{PWM} = 4 kHz.



Motor Selection

Motor selection for asynchronous AC motors (VFC)

8.2.11 DRP motor selection in delta connection type (AC 230 V / 50 Hz)

P _{max} kW (HP) for operation on MOVIDRIVE® MDX61B...-2_3 (AC 230 V units)						
Connection		△ / AC 230 V				
Cooling		Self-cooling		Forced cooling		
f _{min} - f _{max}	Hz	10 - 50 6 - 60 5 - 70 / 5.5 - 80		≤ 2.5 - 50 / ≤ 3 - 60 ¹⁾		
n _{min} - n _{max}	rpm	300 - 1500 180 - 1800 150 - 2100 / 165 - 2400		≤ 75 - 1500 / ≤ 90 - 1800		
Setting range		1:5 1:10 1:15		≥ 1:20		
Motor type	Rated power P _n kW (HP)	P = P _{reduced} kW (HP) With MDX61B...-2_3 ²⁾		P = P _n kW (HP) With MDX61B...-2_3 ³⁾		
DRP90M4	0.75 (1.0)	0.55 (0.74)	0015	0.75 (1.0)	0015	
DRP90L4	1.1 (1.5)	0.75 (1.0)		1.1 (1.5)		
DRP100M4	1.5 (2.0)	1.1 (1.5)		1.5 (2.0)		
DRP100L4	2.2 (3.0)	1.5 (2.0)		2.2 (3.0)		
DRP112M4	3.0 (4.0)	2.2 (3.0)	0022	3.0 (4.0)	0037	
DRP132M4	4.0 (5.4)	3.0 (4.0)	0037	4.0 (5.4)	0055	
DRP132MC4	5.5 (7.4)	4.0 (5.4)	0055	5.5 (7.4)		
DRP160S4				7.5 (10)		0075
DRP160M4	7.5 (10)	5.5 (7.4)	0075	7.5 (10)	0110	
DRP160MC4	9.2 (12)	7.5 (10)		0075		9.2 (12)
DRP180S4						11 (15)
DRP180M4	11 (15)	9.2 (12)	0110	11 (15)	0150	
DRP180L4	15 (20)	11 (15)		15 (20)		
DRP180LC4	18.5 (24.8)	15 (20)	0150	18.5 (24.8)	0220	
DRP200L4				22 (30)		22 (30)
DRP225S4	22 (30)	18.5 (24.8)	0220	22 (30)	0300	
DRP225M4	30 (40)	22 (30)		30 (40)		
DRP225MC4	37 (50)	30 (40)	0300	-	-	

1) Without speed control: f_{min} = 0.5 Hz

2) The units listed here permit intermittent loads of up to 1.5 times the rated load in the specific application. With variable torque load and constant load without overload, each inverter can also be operated with an increased continuous output power (→ MDX60B/61B catalog, Technical Data chapter). The continuous output current of 125 % of the rated unit current is only available at f_{PWM} = 4 kHz.



8.2.12 DRS motor selection in double-star/star connection type (AC 230/460 V / 60 Hz)

P _{max} in kW (HP) for operation on MOVIDRIVE® MDX60/61B...-5_3 (AC 400/500 V units)							
Connection		Δ / AC 460 V			Y / AC 230 V		
Cooling		Self-cooling		Self-cooling	Forced cooling	Self-cooling	Forced cooling
f _{min} - f _{max}	Hz	6 - 90		10 - 60	0 - 60 ¹⁾	10 - 120	0 - 120 ¹⁾
n _{min} - n _{max}	rpm	180 - 2700		300 - 1800	0 - 1800	300 - 3600	0 - 3600
Setting range		1:15		1:6	≥ 1:15	1:12	≥ 1:20
Motor type	Rated power P _n kW (HP)	P = P _{reduced}		P = P _n		P = P _{increased} ²⁾	
		kW (HP)	With MDX60/61B...- 5_3 ³⁾	kW (HP)	With MDX60/61B...- 5_3 ³⁾	kW (HP)	With MDX60/61B...- 5_3 ³⁾
DRS71S4	0.37 (0.5)	0.25 (0.34)	0005/0015	0.37 (0.5)	0005/0015	0.75 (1.0)	0008/0015
DRS71M4	0.55 (0.74)	0.37 (0.5)		0.55 (0.74)		1.1 (1.5)	0011/0015
DRS80S4	0.75 (1.0)	0.55 (0.74)		0.75 (1.0)		0008/0015	1.5 (2.0)
DRS80M4	1.1 (1.5)	0.75 (1.0)	0008/0015	1.1 (1.5)	0011/0015	2.2 (3.0)	0022
DRS90M4	1.5 (2.0)	1.1 (1.5)	0011/0015	1.5 (2.0)	0014/0015	3.0 (4.0)	0030
DRS90L4	2.2 (3.0)	1.5 (2.0)	0014/0015	2.2 (3.0)	0022	4.0 (5.4)	0040
DRS100M4	3.7 (5.0)	2.2 (3.0)	0022	3.7 (5.0)	0040	5.5 (7.4)	0055
DRS100L4	4.0 (5.4)	3.0 (4.0)	0030	4.0 (5.4)		7.5 (10)	0075
DRS112M4					9.2 (12)	0040	5.5 (7.4)
DRS132S4	5.5 (7.4)	4.0 (5.4)	0040	5.5 (7.4)	0055	11 (15)	
DRS132M4	7.5 (10)	5.5 (7.4)	0055	7.5 (10)	0075	15 (20)	0150
DRS132MC4	9.2 (12)	7.5 (10)	0075	9.2 (12)	0110	18.5 (24.8)	
DRS160S4						11 (15)	9.2 (12)
DRS160M4	15 (20)	11 (15)	0110	15 (20)	0150	22 (30)	0220
DRS160MC4	18.5 (24.8)	15 (20)	0150	18.5 (24.8)	0220	30 (40)	
DRS180S4 ⁴⁾						22 (30)	18.5 (24.8)
DRS180M4 ⁴⁾	30 (40)	22 (30)	0220	30 (40)	0300	45 (60)	0450
DRS180L4 ⁴⁾						37 (50)	22 (30)
DRS180LC4 ⁴⁾	45 (60)	37 (50)	0370	45 (60)	0450	75 (100)	0750
DRS200L4 ⁵⁾						55 (74)	45 (60)
DRS225S4 ⁵⁾	110 (148)	90 (120)	0900	110 (148)	1100		
DRS225M4 ⁵⁾	132 (177)	110 (148)	1100	132 (177)	1320		
DRS225MC4 ⁵⁾	160 (215)	132 (177)	1320				
DRS315K4 ⁶⁾							
DRS315S4 ⁶⁾							
DRS315M4 ⁶⁾							

- 1) Without speed control: f_{min} = 0.5 Hz
- 2) P_{increased} means that the motor is operated with increased power (not always with twice the power).
- 3) In each application, the units listed here permit intermittent loads of up to two times the rated load with size 0 (0005 ... 0014) and up to 1.5 times the rated load with sizes 1 ... 6 (0015 ... 1320). With variable torque load and constant load without overload, each inverter can also be operated with an increased continuous output power (→ MDX60B/61B catalog, Technical Data chapter). The continuous output current of 125 % of the rated unit current is only available at f_{PWM} = 4 kHz.
- 4) Maximum permitted motor speed n_{max} = 3400 rpm
- 5) Maximum permitted motor speed n_{max} = 3000 rpm
- 6) Maximum permitted motor speed n_{max} = 2600 rpm



Motor Selection

Motor selection for asynchronous AC motors (VFC)

8.2.13 DRE motor selection in double-star/star connection type (AC 230/460 V / 60 Hz)

P _{max} in kW (HP) for operation on MOVIDRIVE® MDX60/61B...-5_3 (AC 400/500 V units)							
Connection		Δ / AC 460 V			Y / AC 230 V		
Cooling		Self-cooling	Self-cooling	Forced cooling	Self-cooling	Forced cooling	
f _{min} - f _{max}	Hz	6 - 90	10 - 60	0 - 60 ¹⁾	10 - 120	0 - 120 ¹⁾	
n _{min} - n _{max}	rpm	180 - 2700	300 - 1800	0 - 1800	300 - 3600	0 - 3600	
Setting range		1:15	1:6	≥ 1:15	1:12	≥ 1:20	
Motor type	Rated power P _n kW (HP)	P = P _{reduced}		P = P _n		P = P _{increased} ²⁾	
		kW (HP)	With MDX60/61B...- 5_3 ³⁾	kW (HP)	With MDX60/61B...- 5_3 ³⁾	kW (HP)	With MDX60/61B...- 5_3 ³⁾
DRE80M4	0.75 (1.0)	0.55 (0.74)	0005/0015	0.75 (1.0)	0008/0015	1.5 (2.0)	0014/0015
DRE90M4	1.1 (1.5)	0.75 (1.0)	0008/0015	1.1 (1.5)	0011/0015	2.2 (3.0)	0022
DRE90L4	1.5 (2.0)	1.1 (1.5)	0011/0015	1.5 (2.0)	0014/0015	3.0 (4.0)	0030
DRE100L4	2.2 (3.0)	1.5 (2.0)	0014/0015	2.2 (3.0)	0022	4.0 (5.4)	0040
DRE100LC4	3.7 (5.0)	2.2 (3.0)	0022	3.7 (5.0)	0040	5.5 (7.4)	0055
DRE112M4	3.7 (5.0)						
DRE132M4	5.5 (7.4)	4.0 (5.4)	0040	5.5 (7.4)	0055	9.2 (12)	0110
DRE132MC4	7.5 (10)	5.5 (7.4)	0055	7.5 (10)	0075	11 (15)	
DRE160S4							
DRE160M4	9.2 (12)	7.5 (10)	0075	9.2 (12)	0110	15 (20)	0150
DRE160MC4	11 (15)	9.2 (12)	0110	11 (15)		0220	18.5 (24.8)
DRE180S4 ⁴⁾							
DRE180M4 ⁴⁾	15 (20)	11 (15)	0150	15 (20)	0150	22 (30)	0300
DRE180L4 ⁴⁾	18.5 (24.8)	15 (20)		18.5 (24.8)		30 (40)	
DRE180LC4 ⁴⁾	22 (30)	18.5 (24.8)	0220	22 (30)	0220	37 (50)	0370
DRE200L4 ⁵⁾	30 (40)	22 (30)		30 (40)		0300	45 (60)
DRE225S4 ⁵⁾	37 (50)	30 (40)	0300	37 (50)	0370	55 (74)	0550
DRE225M4 ⁵⁾	45 (60)	37 (50)	0370	45 (60)	0450	75 (100)	0750
DRE315K4 ⁶⁾	110 (148)	90 (120)	0900	110 (148)	1100		
DRE315S4 ⁶⁾	132 (177)	110 (148)	1100	132 (177)	1320		
DRE315M4 ⁶⁾	160 (215)	132 (177)	1320				

1) Without speed control: f_{min} = 0.5 Hz

2) P_{increased} means that the motor is operated with increased power (not always with twice the power).

3) In each application, the units listed here permit intermittent loads of up to two times the rated load with size 0 (0005 ... 0014) and up to 1.5 times the rated load with sizes 1 ... 6 (0015 ... 1320). With variable torque load and constant load without overload, each inverter can also be operated with an increased continuous output power (→ MDX60B/61B catalog, Technical Data chapter). The continuous output current of 125 % of the rated unit current is only available at f_{PWM} = 4 kHz.

4) Maximum permitted motor speed n_{max} = 3400 rpm

5) Maximum permitted motor speed n_{max} = 3000 rpm

6) Maximum permitted motor speed n_{max} = 2600 rpm



8.2.14 DR63, DV250, DV280 motor selection with double-star/star connection type (AC 230/460 V / 60 Hz)

P _{max} in kW (HP) for operation on MOVIDRIVE® MDX60/61B...-5_3 (AC 400/500 V units)							
Connection		Δ / AC 460 V			Y / AC 230 V		
Cooling		Self-cooling	Self-cooling	Forced cooling	Self-cooling	Forced cooling	
f _{min} - f _{max}	Hz	6 - 90		10 - 60	0 - 60 ¹⁾	10 - 120	0 - 120 ¹⁾
n _{min} - n _{max}	rpm	180 - 2700		300 - 1800	0 - 1800	300 - 3600	0 - 3600
Setting range		1:15		1:6	≥ 1:15	1:12	≥ 1:20
Motor type	Rated power P _n kW (HP)	P = P _{reduced}		P = P _n		P = P _{increased} ²⁾	
		kW (HP)	With MDX60/61B...- 5_3 ³⁾	kW (HP)	With MDX60/61B...- 5_3 ³⁾	kW (HP)	With MDX60/61B...- 5_3 ³⁾
DR63S4	0.12 (0.16)					0.18 (0.24)	
DR63M4	0.18 (0.24)			0.18 (0.24)	0005	0.25 (0.34)	0005
DR63L4	0.25 (0.34)	0.18 (0.24)	0005	0.25 (0.34)		0.37 (0.5)	
DV250M4 ⁴⁾	55 (74)	45 (60)	0450	55 (74)	0550	90 (120)	0900
DV280S4 ⁴⁾	75 (100)	55 (74)	0550	75 (100)	0750	110 (148)	1100
DV280M4 ⁴⁾	90 (120)	75 (100)	0750	90 (120)	0900	132 (177)	1320

- 1) Without speed control: f_{min} = 0.5 Hz
- 2) P_{increased} means that the motor is operated at the power of the next larger motor (one frame size), rather than with the $\sqrt{3}$ -fold power.
- 3) In each application, the units listed here permit intermittent loads of up to two times the rated load with size 0 (0005 ... 0014) and up to 1.5 times the rated load with sizes 1 ... 6 (0015 ... 1320). With variable torque load and constant load without overload, each inverter can also be operated with an increased continuous output power (→ chapter Technical Data). The continuous output current of 125% of the rated unit current is only available at f_{PWM} = 4 kHz.
- 4) Maximum permitted motor speed n_{max} = 2600 rpm



Motor Selection

Motor selection for asynchronous AC motors (VFC)

8.2.15 DRS motor selection in double-star connection type (AC 230 V / 60 Hz)

P_{max} kW (HP) for operation on MOVIDRIVE® MDX61B...-2_3 (AC 230 V units)				
Connection		/ AC 230 V		
Cooling		Self-cooling	Self-cooling	Forced cooling
$f_{min} - f_{max}$ Hz		6 - 90	10 - 60	0 - 60 ¹⁾
$n_{min} - n_{max}$ rpm		180 - 2700	300 - 1800	0 - 1800
Setting range		1:15	1:6	≥ 1:15
Motor type	Rated power P_n kW (HP)	$P = P_{reduced}$ With MDX61B...-2_3 ²⁾		$P = P_n$ With MDX61B...-2_3 ²⁾
DRS71D4	0.37 (0.5)	0.25 (0.34)	0015	0.37 (0.5)
DRS71M4	0.55 (0.74)	0.37 (0.5)		0.55 (0.74)
DRS80S4	0.75 (1.0)	0.55 (0.74)		0.75 (1.0)
DRS80M4	1.1 (1.5)	0.75 (1.0)		1.1 (1.5)
DRS90M4	1.5 (2.0)	1.1 (1.5)		1.5 (2.0)
DRS90L4	2.2 (3.0)	1.5 (2.0)		2.2 (3.0)
DRS100M4	3.7 (5.0)	2.2 (3.0)		3.7 (5.0)
DRS100L4	4.0 (5.4)	3.0 (4.0)		4.0 (5.4)
DRS112M4				
DRS132S4	5.5 (7.4)	4.0 (5.4)		0055
DRS132M4	7.5 (10)	5.5 (7.4)		7.5 (10)
DRS132MC4			0075	
DRS160S4	9.2 (12)	7.5 (10)		9.2 (12)
DRS160M4	11 (15)	9.2 (12)		11 (15)
DRS160MC4			0110	
DRS180S4	15 (20)	11 (15)		15 (20)
DRS180M4	18.5 (24.8)	15 (20)	0150	18.5 (24.8)
DRS180L4	22 (30)	18.5 (24.8)		22 (30)
DRS180LC4			0220	
DRS200L4	30 (40)	22 (30)		30 (40)
DRS225S4	37 (50)	30 (40)	0300	-

1) Without speed control: $f_{min} = 0.5$ Hz

2) The units listed here permit intermittent loads of up to 1.5 times the rated load in the specific application. With variable torque load and constant load without overload, each inverter can also be operated with an increased continuous output power (→ MDX60B/61B catalog, Technical Data chapter). The continuous output current of 125 % of the rated unit current is only available at $f_{PWM} = 4$ kHz.



8.2.16 DRE motor selection in double-star connection type (AC 230 V / 60 Hz)

P_{max} kW (HP) for operation on MOVIDRIVE® MDX61B...-2_3 (AC 230 V units)				
Connection		/ AC 230 V		
Cooling		Self-cooling		Forced cooling
f_{min} - f_{max} Hz		6 - 90		10 - 60
n_{min} - n_{max} rpm		180 - 2700		300 - 1800
Setting range		1:15		1:6
Motor type	Rated power P_n kW (HP)	P = P_{reduced} With MDX61B...-2_3²⁾		P = P_n With MDX61B...-2_3²⁾
DRE80M4	0.75 (1.0)	0.55 (0.74)	0015	0.75 (1.0)
DRE90M4	1.1 (1.5)	0.75 (1.0)		1.1 (1.5)
DRE90I4	1.5 (2.0)	1.1 (1.5)		1.5 (2.0)
DRE100L4	2.2 (3.0)	1.5 (2.0)		2.2 (3.0)
DRE100LC4	3.7 (5.0)	2.2 (3.0)	0022	3.0 (4.0)
DRE112M4				3.0 (4.0)
DRE132M4	5.5 (7.4)	4.0 (5.4)	0055	5.5 (7.4)
DRE132MC4	7.5 (10)	5.5 (7.4)		7.5 (10)
DRE160S4				7.5 (10)
DRE160M4	9.2 (12)	7.5 (10)	0075	9.2 (12)
DRE160MC4	11 (15)	9.2 (12)		0110
DRE180S4			11 (15)	
DRE180M4			15 (20)	
DRE180L4	18.5 (24.8)	15 (20)	0150	18.5 (24.8)
DRE180LC4	22 (30)	18.5 (24.8)		22 (30)
DRE200L4	30 (40)	22 (30)	0220	30 (40)
DRE225S4	37 (50)	30 (40)		30 (40)

- 1) Without speed control: f_{min} = 0.5 Hz
- 2) The units listed here permit intermittent loads of up to 1.5 times the rated load in the specific application. With variable torque load and constant load without overload, each inverter can also be operated with an increased continuous output power (→ MDX60B/61B catalog, Technical Data chapter). The continuous output current of 125 % of the rated unit current is only available at f_{PWM} = 4 kHz.



Motor Selection

Motor selection for asynchronous AC and servomotors (CFC)

8.3 Motor selection for asynchronous AC and servomotors (CFC)

	INFORMATION
	<p>The torque limit (M limit) is set automatically by the startup function of the MOVITOOLS® MotionStudio engineering software. Do not increase this automatically set value!</p> <p>SEW-EURODRIVE recommends always using the latest version of MOVITOOLS® MotionStudio for startup. The latest MOVITOOLS® MotionStudio version can be downloaded from our homepage (www.sew-eurodrive.de).</p>

8.3.1 Motor characteristics

Drives in CFC operating modes are characterized by their ability to control torque directly and quickly. This means it achieves a high level of dynamic overload capacity (up to $3 \times M_N$) and a very high speed and control range (up to 1:5000). Stable speed and positioning accuracy meet the high requirements of servo technology. These characteristics are made possible through field-oriented control. The current components for magnetization (I_d) and torque generation (I_q) are controlled separately. A prerequisite for the CFC operating modes is that the motor must always be equipped with an encoder.

The inverter needs to know exact data about the motor connected to calculate the motor model. These data are made available by the MOVITOOLS® MotionStudio engineering software with the startup function. The CFC operating modes are only possible with the SEW motors listed in the following chapters. They cannot be used with other SEW motors or non-SEW motors. The necessary motor data for the CFC operating modes are stored in MOVIDRIVE® for the 4-pole SEW motors.

8.3.2 Magnetizing current

Dynamic drives that have to accelerate without a delay are also energized at standstill without load. The magnetizing current I_d flows at standstill. The inverter must be able to supply this current constantly in applications in which the output stage is permanently enabled, for example in CFC & M-CONTROL mode. In particular in the case of large motors with a slip frequency ≤ 2 Hz, you must refer to the diagrams in chapter "Load capacity of the units at low output frequencies" to check whether the inverter can supply the current. Also check whether the thermal characteristics of the motor are suitable (forced cooling fan) for this. For the magnetization current I_d , refer to the motor tables.



8.3.3 CFC operation with speed control

There is no need to differentiate between the load types quadratic, dynamic and static when performing project planning for the CFC operating mode. Project planning for an asynchronous motor in CFC mode is carried out in accordance with the following requirements:

1. Effective torque requirement at average application speed.

$$M_{r.m.s.} < M_{N_mot}$$

The operating point must lie below the characteristic curve for the continuous torque. No forced cooling is required if this operating point lies below the characteristic curve for self-cooling.

2. Maximum torque needed across the speed curve.

$$M_{max} < M_{dyn_mot}$$

This operating point must lie below the characteristic curve for the maximum torque of the motor/MOVIDRIVE® combination.

3. Maximum speed

Do not configure the maximum speed of the motor higher than 1.4 times the transition speed. The maximum torque available will then still be approx. 110 % of the continuous rated torque of the motor; also, the input speed for the gear unit connected to the motor output will still be less than 3000 rpm with delta connection.

$$n_{max} < 1.4 \times n_{base} < 3000 \text{ rpm}$$

8.3.4 Motor cooling

Self-cooling of asynchronous motors is based on the integrated fan, which means self-cooling depends on the speed. The integrated fan does not provide cooling for the motor at low speeds and standstill. Forced cooling may be necessary in case of a high static load or a high effective torque.



8.3.5 CFC operation with speed control (CFC & M-CONTROL)

This operating mode permits direct torque control of the asynchronous motor in the basic speed range ($n \leq n_{\text{base}}$). The setpoint sources of the speed-controlled CFC mode can also be used for torque control. All speed setpoint sources (except for bus setpoints) are interpreted as current setpoint sources. Assign "Current" to a process data word for fieldbus control. The settings for evaluating the analog input (\rightarrow P11_, parameter description) also remain in effect. The fixed setpoints (P16_, P17_) can be entered either in the unit (rpm) or ($\%I_{N_inverter}$) (\rightarrow MOVITOOLS[®] MotionStudio).

The following relationship exists between the units:

$$3000 \text{ rpm} = 150 \% \text{ inverter rated current}$$

The torque on the output shaft of the motor can be calculated for the basic speed range ($n \leq n_{\text{base}}$) using the following formulae:

Specification of a setpoint for the motor torque in $\%I_{N_inverter}$:

$$M = k_T \times I_{N_inverter} \times \text{setpoint}$$

1477199499

Specification of a setpoint for the motor torque in rpm:

$$M = k_T \times 1.5 \times I_{N_inverter} \times \frac{\text{setpoint}}{3000 \text{ 1/min}}$$

1477203211

$I_{N_inverter}$ = Rated output current of the inverter

k_T = Torque constant = M_n / I_{q_n}

M_n and I_{q_n} are motor-specific values. For the values of the torque constants k_T and the motor-specific parameters M_n and I_{q_n} , refer to the motor tables.

In addition to the current I_q for creating the torque, the inverter also needs to supply the magnetizing current I_d . The actual inverter output current I_{tot} can be calculated using the following formulae:

Specification of a setpoint for the motor torque in $\%I_{N_inverter}$:

$$I_{\text{total}} = \sqrt{\left(\text{setpoint} \times I_{N_inverter}\right)^2 + I_{d_N}^2}$$

1477206667

Specification of a setpoint for the motor torque in rpm:

$$I_{\text{total}} = \sqrt{\left(\text{setpoint} \times 1.5 \times I_{N_inverter} \times \frac{1}{3000 \text{ rpm}}\right)^2 + I_{d_N}^2}$$

1477274379

I_{q_n} = Nominal value for the current which generates the torque, according to the motor table

I_{d_n} = Nominal value of the magnetizing current according to the motor table



8.3.6 Asynchronous DRL servomotors

SEW-EURODRIVE offers DRL series asynchronous servomotors especially for operation with MOVIDRIVE® in CFC operating modes. These motors have the following characteristics:

- High power yield* The optimum winding of DRL motors permits a high power yield.

- Classification into speed classes* DRL motors are available in four speed classes. This division ensures optimum utilization of torque and speed.

- With sin/cos encoder as standard* As standard, DRL motors are equipped with a high-resolution sin/cos encoder (ES7S, EG7S).

- With TF or TH motor protection as standard* The winding temperature of the three motor phases is monitored using temperature sensors (TF). The thermistor can be connected to the TF/TH input of MOVIDRIVE®. The temperature is then monitored by MOVIDRIVE®; no additional monitoring unit is required.
 Bimetallic switches (TH) can also be used instead of thermistors. The bimetallic switches are also connected to the TF/TH input.

- Thermal classification 155 (F) as standard* DRL motors are built using material of thermal classification 155 (F) as standard.

- Dynamics packages 1 and 2* DRL motors are available in two dynamics packages. The motors differ in their overload capacity related to the motor torque.
 - Dynamics package 1: 190% - 220% nominal motor torque
 - Dynamics package 2: 300% - 350% nominal motor torque

DRS, DRE, DRP motors or DRL motors can be used in CFC mode. SEW-EURODRIVE recommends using DRL motors to achieve optimum benefit from the advantages of CFC mode.

	Advantage	Disadvantage
CFC mode with DRS, DRE, DRP motor selection	Standard motor version	Slower transition speed than the DRL motor.
		The power yield of the motor is less than the rated motor power.
		In terms of the power yield, the mass inertia is greater than that of the DRL motors.
		The maximum torque is limited for some of the inverter/motor combinations due to mechanical rigidity.
CFC mode with DRL motor Motor selection	Higher transition speed than DRS, DRE, DRP motors.	No IEC standard motor
	Usually with a power yield one motor type higher.	
	Based on the power yield of a lower mass moment of inertia.	Higher current demand due to higher power yield; therefore a larger inverter has to be assigned.
	Motor is designed for dynamic operation.	



Motor Selection

Motor selection for asynchronous AC and servomotors (CFC)

8.3.7 DRL motor table

n_N rpm	Motor	P_m kW	M_N Nm (lb in)	I_N A	I_{q_n} A	I_{d_n} A	k_T Nm/A (lb in/A)	M_{max} Dyn1 Nm (lb in)	M_{max} Dyn2 Nm (lb in)	J_{mot} 10^{-4} kgm ²	J_{BMot}
1200	DRL71S4	0.37	2.7 (24)	1.18	1.02	0.62	2.66 (23.5)	5 (44)	8.5 (75)	4.9	6.2
	DRL71M4	0.55	4 (35)	1.6	1.36	0.80	2.93 (25.9)	7 (62)	14 (124)	7.1	8.4
	DRL80S4	0.75	6.5 (58)	2.15	1.95	0.88	3.33 (29.5)	10 (89)	25 (221)	14.9	19.4
	DRL80M4	1.1	9.5 (84)	2.9	2.64	1.10	3.60 (31.9)	14 (124)	30 (266)	21.5	26
	DRL90L4	2.2	15 (133)	4.8	4.14	2.21	3.63 (32.1)	25 (221)	46 (407)	43.5	49.5
	DRL100L4	2.2	26 (230)	8.50	8.05	2.68	3.23 (28.6)	40 (354)	85 (752)	68	74
	DRL132S4	5.5	42 (372)	12.6	11.9	4.07	3.52 (31.2)	80 (708)	150 (1328)	190	200
	DRL132MC4	9.2	56 (496)	17.6	15.4	7.50	3.63 (32.1)	130 (1151)	200 (1770)	340	355
	DRL160M4	11	85 (752)	25.5	24.2	8.05	3.51 (31.1)	165 (1460)	280 (2478)	450	500
	DRL160MC4	15	90 (797)	28	25.1	10.9	3.58 (31.7)	185 (1637)	320 (2832)	590	640
	DRL180S4	15	120 (1062)	34.5	33.2	10.8	3.62 (32.0)	210 (1859)	380 (3363)	900	1030
	DRL180M4	18.5	135 (1195)	38	36.1	11.3	3.74 (33.1)	250 (2213)	430 (3806)	1110	1250
	DRL180L4	22	165 (1460)	47	44.9	14.8	3.67 (32.5)	320 (2832)	520 (4602)	1300	1440
	DRL180LC4	30	175 (1549)	52	46.8	17.1	3.74 (33.1)	420 (3717)	600 (5310)	1680	1910
	DRL200L4	30	200 (1770)	58.5	56.0	17.8	3.57 (31.6)	475 (4204)	680 (6019)	2360	2590
	DRL225S4	37	250 (2213)	72	68.1	23.4	3.67 (32.5)	520 (4602)	770 (6815)	2930	3160
DRL225MC4	55	290 (2567)	89	78.6	29.2	3.69 (32.7)	770 (6815)	1100 (9736)	4330	4560	
1700	DRL71S4	0.37	2.7 (24)	1.63	1.40	0.86	1.92 (17.0)	5 (44)	8.5 (75)	4.9	6.2
	DRL71M4	0.55	4 (35)	2.20	1.90	1.11	2.11 (18.7)	7 (62)	14 (124)	7.1	8.4
	DRL80S4	0.75	6.5 (58)	2.96	2.71	1.22	2.40 (21.2)	10 (89)	25 (221)	14.9	19.4
	DRL80M4	1.1	9.5 (84)	4.00	3.65	1.52	2.60 (23.0)	14 (124)	30 (266)	21.5	26
	DRL90L4	2.2	15 (133)	6.60	5.67	3.02	2.65 (23.5)	25 (221)	46 (407)	43.5	49.5
	DRL100L4	2.2	26 (230)	11.40	11.00	3.66	2.36 (20.9)	40 (354)	85 (752)	68	74
	DRL132S4	5.5	42 (372)	17.80	16.9	5.75	2.49 (22.0)	80 (708)	150 (1328)	190	200
	DRL132MC4	9.2	56 (496)	24.90	21.9	10.6	2.56 (22.7)	130 (1151)	200 (1770)	340	355
	DRL160M4	11	85 (752)	35.00	33.5	11.1	2.54 (22.5)	165 (1460)	280 (2478)	450	500
	DRL160MC4	15	90 (797)	36.00	32.3	14.0	2.78 (24.6)	185 (1637)	320 (2832)	590	640
	DRL180S4	15	120 (1062)	47.50	45.6	14.8	2.63 (23.3)	210 (1859)	380 (3363)	900	1030
	DRL180M4	18.5	135 (1195)	52.00	50.1	15.7	2.70 (23.9)	250 (2213)	430 (3806)	1110	1250
	DRL180L4	22	165 (1460)	63.00	61.3	20.2	2.69 (23.8)	320 (2832)	520 (4602)	1300	1440
	DRL180LC4	30	175 (1549)	72.00	65.7	24.1	2.66 (23.5)	420 (3717)	600 (5310)	1680	1910
	DRL200L4	30	200 (1770)	80.60	78.4	25.0	2.55 (22.6)	475 (4204)	680 (6019)	2360	2590
	DRL225S4	37	245 (2168)	97.00	92	32.2	2.66 (23.5)	520 (4602)	770 (6815)	2930	3160
DRL225MC4	55	280 (2478)	130.00	114	43.9	2.45 (21.7)	770 (6815)	1100 (9736)	4330	4560	
2100	DRL71S4	0.37	2.6 (23)	2.00	1.70	1.08	1.53 (13.5)	4.9 (43)	6.2 (55)	4.9	6.2
	DRL71M4	0.55	3.8 (34)	2.70	2.25	1.39	1.69 (15.0)	7.1 (63)	8.4 (74)	7.1	8.4
	DRL80S4	0.75	6.2 (55)	3.59	3.22	1.52	1.92 (17.0)	14.9 (132)	19.4 (172)	14.9	19.4
	DRL80M4	1.1	9.5 (84)	5.00	4.60	1.91	2.07 (18.3)	21.5 (190)	26 (230)	21.5	26
	DRL90L4	2.2	15 (133)	8.40	7.21	3.84	2.08 (18.4)	43.5 (385)	49.5 (438)	43.5	49.5
	DRL100L4	2.2	25 (221)	14.0	13.4	4.63	1.87 (16.6)	68 (602)	74 (655)	68	74
	DRL132S4	5.5	41 (363)	21.4	20.3	7.07	2.02 (17.9)	190 (1682)	200 (1770)	190	200
	DRL132MC4	9.2	52 (460)	28.8	25.0	13.0	2.08 (18.4)	340 (3009)	355 (3142)	340	355
	DRL160M4	11	85 (752)	44.0	42.1	14.0	2.02 (17.9)	450 (3983)	500 (4425)	450	500
	DRL160MC4	15	88 (779)	48.0	42.8	18.9	2.06 (18.2)	590 (5222)	640 (5664)	590	640
	DRL180S4	15	110 (974)	55.3	52.7	18.7	2.09 (18.5)	900 (7966)	1030 (9116)	900	1030
	DRL180M4	18.5	130 (1151)	64.0	60.4	19.6	2.15 (19.0)	1110 (9824)	1250 (11063)	1110	1250
	DRL180L4	22	160 (1416)	78.0	75.8	25.8	2.11 (18.7)	1300 (11506)	1440 (12745)	1300	1440
	DRL180LC4	30	170 (1505)	87.0	79.1	29.8	2.15 (19.0)	1680 (14869)	1910 (16905)	1680	1910
	DRL200L4	30	195 (1726)	99.0	94.6	30.9	2.06 (18.2)	2360 (20888)	2590 (22923)	2360	2590
	DRL225S4	37	235 (2080)	119	111	40.6	2.11 (18.7)	2930 (25933)	3160 (27968)	2930	3160
DRL225MC4	55	265 (2345)	142	125	50.8	2.12 (18.8)	4330 (38324)	4560 (40359)	4330	4560	



n_N rpm	Motor	P_m kW	M_N Nm (lb in)	I_N A	I_{q_n} A	I_{d_n} A	k_T Nm/A (lb in/A)	M_{max} Dyn1 Nm (lb in)	M_{max} Dyn2 Nm (lb in)	J_{mot} 10^{-4} kgm ²	J_{BMot} 10^{-4} kgm ²
3000	DRL71S4	0.37	2.5 (22)	2.68	2.26	1.49	1.11 (9.8)	5 (44)	8.5 (75)	4.9	6.2
	DRL71M4	0.55	3.6 (32)	3.55	2.96	1.93	1.21 (10.7)	7 (62)	14 (124)	7.1	8.4
	DRL80S4	0.75	6 (53)	4.82	4.32	2.10	1.39 (12.3)	10 (89)	25 (221)	14.9	19.4
	DRL80M4	1.1	8.8 (78)	6.50	5.86	2.63	1.50 (13.3)	14 (124)	30 (266)	21.5	26
	DRL90L4	2.2	14 (124)	11.0	9.19	5.25	1.52 (13.5)	25 (221)	46 (407)	43.5	49.5
	DRL100L4	2.2	21 (186)	16.6	15.4	6.35	1.36 (12.0)	40 (354)	85 (752)	68	74
	DRL132S4	5.5	35 (310)	25.5	24.4	10.0	1.43 (12.7)	80 (708)	150 (1328)	190	200
	DRL132MC4	9.2	42 (372)	34.8	28.4	18.4	1.48 (13.1)	130 (1151)	200 (1770)	340	355
	DRL160M4	11	79 (699)	57.0	53.9	19.3	1.47 (13.0)	165 (1460)	280 (2478)	450	500
	DRL160MC4	15	83 (735)	59.0	51.8	24.3	1.60 (14.2)	185 (1637)	320 (2832)	590	640
	DRL180S4	15	100 (885)	70.1	65.9	25.7	1.52 (13.5)	210 (1859)	380 (3363)	900	1030
	DRL180M4	18.5	105 (929)	73.0	67.6	27.2	1.55 (13.7)	250 (2213)	430 (3806)	1110	1250
	DRL180L4	22	130 (1151)	90.0	83.8	35.0	1.55 (13.7)	320 (2832)	520 (4602)	1300	1440
	DRL180LC4	30	140 (1239)	105	91	41.8	1.53 (13.5)	420 (3717)	600 (5310)	1680	1910
	DRL200L4	30	165 (1460)	118	112	43.3	1.47 (13.0)	475 (4204)	680 (6019)	2360	2590
	DRL225S4	37	195 (1726)	139	127	56.0	1.53 (13.5)	520 (4602)	770 (6815)	2930	3160
	DRL225MC4	55	220 (1947)	188	156	76	1.41 (12.5)	770 (6815)	1100 (9736)	4330	4560



Motor Selection

Motor selection for asynchronous AC and servomotors (CFC)

8.3.8 Combination overview for DRL motors with MOVIDRIVE® B (line voltage 400 V)

Nominal speed $n_N = 1200$ rpm, dynamics package 1

Assignment of MOVIDRIVE® MDX61B0005-5A3 ... MDX61B0110-503 (sizes 0 – 2):

Motor			MOVIDRIVE® MDX61B...-5_3 (AC 400/500 V units) in CFC operating modes (P700)										
			0005	0008	0011	0014	0015	0022	0030	0040	0055	0075	0110
DRL71S4	M_{max}	Nm (lb in)	5 (44)				5 (44)						
	n_{base}	rpm	834				843						
DRL71M4	M_{max}	Nm (lb in)	7 (62)				7 (62)						
	n_{base}	rpm	849				849						
DRL80S4	M_{max}	Nm (lb in)	10 (89)		10 (89)								
	n_{base}	rpm	914		914								
DRL80M4	M_{max}	Nm (lb in)	14 (124)	14 (124)	14 (124)		14 (124)						
	n_{base}	rpm	890	966	984		984						
DRL90L4	M_{max}	Nm (lb in)				25 (221)	19.7 (174)	25 (221)	25 (221)				
	n_{base}	rpm				978	996	990	1037				
DRL100L4	M_{max}	Nm (lb in)						25.7 (227)	33.1 (293)	40 (354)			
	n_{base}	rpm						1166	1084	1043			
DRL132S4	M_{max}	Nm (lb in)							48.2 (427)	64.8 (574)	80 (708)	80 (708)	
	n_{base}	rpm							1049	966	903	908	
DRL132MC4	M_{max}	Nm (lb in)									80.9 (716)	125 (1106)	
	n_{base}	rpm									1059	947	
DRL160M4	M_{max}	Nm (lb in)										123 (1089)	
	n_{base}	rpm										1032	
DRL160MC4	M_{max}	Nm (lb in)										119 (1053)	
	n_{base}	rpm										1085	
DRL180S4	M_{max}	Nm (lb in)										125 (1106)	
	n_{base}	rpm										1125	

Assignment of MOVIDRIVE® MDX61B0150-503 ... MDX61B1320-503 (sizes 3 – 6):

Motor			MOVIDRIVE® MDX61B...-5_3 (AC 400/500 V units) in CFC operating modes (P700)										
			0150	0220	0300	0370	0450	0550	0750	0900	1100	1320	
DRL132MC4	M_{max}	Nm (lb in)	130 (1151)										
	n_{base}	rpm	996										
DRL160M4	M_{max}	Nm (lb in)	165 (1460)	165 (1460)									
	n_{base}	rpm	931	940									
DRL160MC4	M_{max}	Nm (lb in)	164 (1452)	185 (1637)	185 (1637)								
	n_{base}	rpm	1006	1032	1032								
DRL180S4	M_{max}	Nm (lb in)	170 (1505)	210 (1859)									
	n_{base}	rpm	1063	1067									



Motor			MOVIDRIVE® MDX61B...-5_3 (AC 400/500 V units) in CFC operating modes (P700)								
			0150	0220	0300	0370	0450	0550	0750	0900	1100
DRL180M4	M _{max}	Nm	174	250	250						
		(lb in)	(1540)	(2213)	(2213)						
	n _{base}	rpm	1069	999	1065						
DRL180L4	M _{max}	Nm	171	255	320	320					
		(lb in)	(1513)	(2257)	(2832)	(2832)					
	n _{base}	rpm	1089	1022	999	1062					
DRL180LC4	M _{max}	Nm		243	324	397	420				
		(lb in)		(2151)	(2868)	(3514)	(3717)				
	n _{base}	rpm		1065	1009	952	979				
DRL200L4	M _{max}	Nm		239	317	388	475				
		(lb in)		(2115)	(2806)	(3434)	(4204)				
	n _{base}	rpm		1128	1066	1000	925				
DRL225S4	M _{max}	Nm			319	393	484	520			
		(lb in)			(2823)	(3478)	(4284)	(4602)			
	n _{base}	rpm			1110	1069	1110	1025			
DRL225MC4	M _{max}	Nm					466	558	700	770	
		(lb in)					(4124)	(4939)	(6196)	(6815)	
	n _{base}	rpm					1031	996	937	937	



Motor Selection

Motor selection for asynchronous AC and servomotors (CFC)

Nominal speed $n_N = 1200$ rpm, dynamics package 2

Assignment of **MOVIDRIVE® MDX61B0005-5A3 ... MDX61B0110-503** (sizes 0 – 2):

Motor		MOVIDRIVE® MDX61B...-5_3 (AC 400/500 V units) in CFC operating modes (P700)											
		0005	0008	0011	0014	0015	0022	0030	0040	0055	0075	0110	
DRL71S4	M_{max}	Nm (lb in)	8.5 (75)				8.5 (75)						
	n_{base}	rpm	457				457						
DRL71M4	M_{max}	Nm (lb in)	11.6 (103)	14 (124)			14 (124)						
	n_{base}	rpm	521	369			369						
DRL80S4	M_{max}	Nm (lb in)	13 (115)	15.7 (139)	20.4 (181)	25 (221)	19.7 (174)	25 (221)					
	n_{base}	rpm	738	613	386	181	416	181					
DRL80M4	M_{max}	Nm (lb in)	14 (124)	17.1 (151)	22.4 (198)	29.2 (258)	21.7 (192)	30 (266)					
	n_{base}	rpm	890	808	668	498	691	480					
DRL90L4	M_{max}	Nm (lb in)				27.4 (243)	19.7 (174)	28.4 (251)	36.8 (326)	46 (407)			
	n_{base}	rpm				896	996	884	773	650			
DRL100L4	M_{max}	Nm (lb in)						25.3 (224)	33.1 (293)	45.7 (404)	60.5 (535)	77.8 (689)	
	n_{base}	rpm						1166	1084	949	785	609	
DRL132S4	M_{max}	Nm (lb in)								48.2 (427)	64.8 (574)	83.8 (742)	126 (1115)
	n_{base}	rpm								1049	966	874	664
DRL132MC4	M_{max}	Nm (lb in)										80.9 (716)	125 (1106)
	n_{base}	rpm										1059	947
DRL160M4	M_{max}	Nm (lb in)											123 (1089)
	n_{base}	rpm											1032
DRL160MC4	M_{max}	Nm (lb in)											119 (1053)
	n_{base}	rpm											1085
DRL180S4	M_{max}	Nm (lb in)											125 (1106)
	n_{base}	rpm											1125

Assignment of **MOVIDRIVE® MDX61B0150-503 ... MDX61B1320-503** (sizes 3 – 6):

Motor		MOVIDRIVE® MDX61B...-5_3 (AC 400/500 V units) in CFC operating modes (P700)											
		0150	0220	0300	0370	0450	0550	0750	0900	1100	1320		
DRL132S4	M_{max}	Nm (lb in)	150 (1328)										
	n_{base}	rpm	561										
DRL132MC4	M_{max}	Nm (lb in)	169 (1496)	200 (1770)									
	n_{base}	rpm	835	752									
DRL160M4	M_{max}	Nm (lb in)	167 (1478)	241 (2133)	280 (2478)								
	n_{base}	rpm	922	747	663								
DRL160MC4	M_{max}	Nm (lb in)	164 (1452)	240 (2124)	314 (2779)	320 (2832)							
	n_{base}	rpm	1006	870	742	733							
DRL180S4	M_{max}	Nm (lb in)	170 (1505)	248 (2195)	326 (2885)	380 (3363)							
	n_{base}	rpm	1063	940	821	738							



Motor			MOVIDRIVE® MDX61B...-5_3 (AC 400/500 V units) in CFC operating modes (P700)									
			0150	0220	0300	0370	0450	0550	0750	0900	1100	1320
DRL180M4	M _{max}	Nm (lb in)	174 (1540)	255 (2257)	335 (2965)	409 (3620)	430 (3806)					
	n _{base}	rpm	1069	979	886	800	777					
DRL180L4	M _{max}	Nm (lb in)	171 (1513)	255 (2257)	337 (2983)	413 (3655)	505 (4470)	520 (4602)				
	n _{base}	rpm	1089	1022	952	886	806	793				
DRL180LC4	M _{max}	Nm (lb in)		243 (2151)	324 (2868)	397 (3514)	488 (4319)	578 (5116)	600 (5310)			
	n _{base}	rpm		1065	1009	952	879	810	793			
DRL200L4	M _{max}	Nm (lb in)			239 (2115)	317 (2806)	388 (3434)	475 (4204)	561 (4965)	680 (6019)		
	n _{base}	rpm			1128	1066	1000	925	847	753		
DRL225S4	M _{max}	Nm (lb in)			319 (2823)	393 (3478)	484 (4284)	574 (5080)	713 (6311)	770 (6815)		
	n _{base}	rpm			1110	1069	1010	955	864	829		
DRL225MC4	M _{max}	Nm (lb in)					466 (4124)	558 (4939)	700 (6196)	922 (8160)	1089 (9638)	1100 (9736)
	n _{base}	rpm					1031	996	937	843	776	773



Motor Selection

Motor selection for asynchronous AC and servomotors (CFC)

Nominal speed $n_N = 1700$ rpm, dynamics package 1

Assignment of **MOVIDRIVE® MDX61B0005-5A3 ... MDX61B0110-503** (sizes 0 – 2):

Motor			MOVIDRIVE® MDX61B...-5_3 (AC 400/500 V units) in CFC operating modes (P700)										
			0005	0008	0011	0014	0015	0022	0030	0040	0055	0075	0110
DRL71S4	M_{max}	Nm (lb in)	5 (44)				5 (44)						
	n_{base}	rpm	1347				1347						
DRL71M4	M_{max}	Nm (lb in)	7 (62)				7 (62)						
	n_{base}	rpm	1347				1347						
DRL80S4	M_{max}	Nm (lb in)	9.1 (81)	10 (89)			10 (89)						
	n_{base}	rpm	1429	1447			1500						
DRL80M4	M_{max}	Nm (lb in)			14 (124)	14 (124)	14 (124)	14 (124)					
	n_{base}	rpm			1441	1564	1412	1564					
DRL90L4	M_{max}	Nm (lb in)						19.8 (175)	25 (221)	25 (221)			
	n_{base}	rpm						1429	1400	1564			
DRL100L4	M_{max}	Nm (lb in)							23.3 (206)	32.8 (290)	40 (708)	40 (708)	
	n_{base}	rpm							1669	1558	1517	1529	
DRL132S4	M_{max}	Nm (lb in)									44.6 (395)	58.4 (517)	80 (708)
	n_{base}	rpm									1547	1464	1362
DRL132MC4	M_{max}	Nm (lb in)											86.2 (763)
	n_{base}	rpm											1528
DRL160M4	M_{max}	Nm (lb in)											87.3 (773)
	n_{base}	rpm											1573

Assignment of **MOVIDRIVE® MDX61B0150-503 ... MDX61B1320-503** (sizes 3 – 6):

Motor			MOVIDRIVE® MDX61B...-5_3 (AC 400/500 V units) in CFC operating modes (P700)										
			0150	0220	0300	0370	0450	0550	0750	0900	1100	1320	
DRL132MC4	M_{max}	Nm (lb in)	117 (1036)	130 (1151)									
	n_{base}	rpm	1425	1484									
DRL160M4	M_{max}	Nm (lb in)	119 (1053)	165 (1460)									
	n_{base}	rpm	1476	1353									
DRL160MC4	M_{max}	Nm (lb in)	124 (1097)	184 (1629)	185 (1637)								
	n_{base}	rpm	1406	1278	1362								
DRL180S4	M_{max}	Nm (lb in)	121 (1071)	179 (1584)	210 (1859)	210 (1859)							
	n_{base}	rpm	1586	1485	1498	1529							
DRL180M4	M_{max}	Nm (lb in)		181 (1602)	240 (2124)	250 (2213)	250 (2213)						
	n_{base}	rpm		1500	1421	1517	1530						
DRL180L4	M_{max}	Nm (lb in)		181 (1602)	243 (2151)	299 (2646)	320 (2832)	320 (2832)					
	n_{base}	rpm		1497	1441	1381	1464	1507					
DRL180LC4	M_{max}	Nm (lb in)			224 (1983)	278 (2461)	344 (2956)	409 (3620)	420 (3717)				
	n_{base}	rpm			1534	1487	1427	1361	1441				



Motor			MOVIDRIVE® MDX61B...-5_3 (AC 400/500 V units) in CFC operating modes (P700)									
			0150	0220	0300	0370	0450	0550	0750	0900	1100	1320
DRL200L4	M _{max}	Nm (lb in)			221 (1956)	273 (2416)	336 (2974)	399 (3531)	475 (4201)			
	n _{base}	rpm			1621	1566	1496	1424	1332			
DRL225S4	M _{max}	Nm (lb in)				279 (2469)	346 (3062)	412 (3647)	515 (4558)	520 (4602)		
	n _{base}	rpm				1576	1529	1476	1391	1467		
DRL225MC4	M _{max}	Nm (lb in)							453 (4009)	606 (5364)	719 (6364)	770 (6815)
	n _{base}	rpm							1576	1494	1429	1447

Nominal speed n_N = 1700 rpm, dynamics package 2

Assignment of MOVIDRIVE® MDX61B0005-5A3 ... MDX61B0110-503 (sizes 0 – 2):

Motor			MOVIDRIVE® MDX61B...-5_3 (AC 400/500 V units) in CFC operating modes (P700)										
			0005	0008	0011	0014	0015	0022	0030	0040	0055	0075	0110
DRL71S4	M _{max}	Nm (lb in)	7.6 (67)	8.5 (75)			8.5 (75)						
	n _{base}	rpm	960	949			849						
DRL71M4	M _{max}	Nm (lb in)	8.2 (73)	10 (89)	14 (124)	14 (124)	13 (115)	14 (124)					
	n _{base}	rpm	1195	1043	732	849	914	849					
DRL80S4	M _{max}	Nm (lb in)	9.1 (81)	11.1 (98)	14.6 (129)	18.9 (167)	14.1 (125)	19.5 (173)	25 (221)				
	n _{base}	rpm	1429	1318	1130	896	1154	861	591				
DRL80M4	M _{max}	Nm (lb in)			20.9 (185)	20.3 (180)	15.4 (136)	21.6 (191)	27.8 (246)	30 (266)			
	n _{base}	rpm			1136	1242	1294	1119	943	955			
DRL90L4	M _{max}	Nm (lb in)						19.8 (175)	26.2 (232)	36.9 (327)	46 (407)		
	n _{base}	rpm						1429	1335	1236	1037		
DRL100L4	M _{max}	Nm (lb in)							23.3 (206)	33.3 (295)	43.8 (388)	56.5 (500)	85 (752)
	n _{base}	rpm							1669	1564	1412	1248	896
DRL132S4	M _{max}	Nm (lb in)									44.6 (395)	58.4 (517)	89.2 (789)
	n _{base}	rpm									1547	1464	1269
DRL132MC4	M _{max}	Nm (lb in)											86.2 (763)
	n _{base}	rpm											1528
DRL160M4	M _{max}	Nm (lb in)											87.3 (773)
	n _{base}	rpm											1573

Assignment of MOVIDRIVE® MDX61B0150-503 ... MDX61B1600-503 (sizes 3 – 7):

Motor			MOVIDRIVE® MDX61B...-5_3 (AC 400/500 V units) in CFC operating modes (P700)										
			0150	0220	0300	0370	0450	0550	0750	0900	1100	1320	1600
DRL132S4	M _{max}	Nm (lb in)	119.4 (1057)	150 (1328)									
	n _{base}	rpm	1079	903									
DRL132MC4	M _{max}	Nm (lb in)	117 (1036)	171 (1513)	200 (1770)								
	n _{base}	rpm	1425	1240	1147								
DRL160M4	M _{max}	Nm (lb in)	119 (1053)	174 (1540)	227 (2009)	278 (2461)	280 (2478)						
	n _{base}	rpm	1476	1305	1138	993	988						



Motor Selection

Motor selection for asynchronous AC and servomotors (CFC)

Motor			MOVIDRIVE® MDX61B...-5_3 (AC 400/500 V units) in CFC operating modes (P700)										
			0150	0220	0300	0370	0450	0550	0750	0900	1100	1320	1600
DRL160MC4	M _{max}	Nm (lb in)	124 (1097)	184 (1629)	243 (2151)	297 (2629)	320 (2832)						
	n _{base}	rpm	1406	1278	1151	1037	988						
DRL180S4	M _{max}	Nm (lb in)	121 (1071)	179 (1584)	235 (2080)	288 (2549)	352 (3115)	380 (3363)					
	n _{base}	rpm	1586	1485	1371	1270	1142	1089					
DRL180M4	M _{max}	Nm (lb in)		181 (1602)	240 (2124)	294 (2602)	360 (3186)	425 (3762)	430 (3806)				
	n _{base}	rpm		1500	1421	1341	1241	1145	1138				
DRL180L4	M _{max}	Nm (lb in)		181 (1602)	243 (2151)	299 (2646)	368 (3257)	436 (3859)	520 (4602)				
	n _{base}	rpm		1497	1441	1381	1308	1231	1138				
DRL180LC4	M _{max}	Nm (lb in)			224 (1983)	278 (2461)	344 (3045)	409 (3620)	509 (4505)	600 (5310)			
	n _{base}	rpm			1534	1487	1427	1361	1258	1165			
DRL200L4	M _{max}	Nm (lb in)			221 (1956)	273 (2416)	336 (2974)	399 (3531)	495 (4381)	650 (5753)	680 (6019)		
	n _{base}	rpm			1621	1566	1496	1424	1304	1128	1097		
DRL225S4	M _{max}	Nm (lb in)				279 (2469)	346 (3062)	412 (3647)	515 (4558)	678 (6001)	770 (6815)		
	n _{base}	rpm				1576	1529	1576	1391	1253	1177		
DRL225MC4	M _{max}	Nm (lb in)							453 (4009)	606 (5364)	719 (6364)	904 (8001)	1089 (9638)
	n _{base}	rpm							1576	1494	1429	1318	1210



Nominal speed $n_N = 2100$ rpm, dynamics package 1

Assignment of MOVIDRIVE® MDX61B0005-5A3 ... MDX61B0110-503 (sizes 0 – 2):

Motor		MOVIDRIVE® MDX61B...-5_3 (AC 400/500 V units) in CFC operating modes (P700)											
		0005	0008	0011	0014	0015	0022	0030	0040	0055	0075	0110	
DRL71S4	M_{max}	Nm (lb in)	5 (44)				5 (44)						
	n_{base}	rpm	1804				1804						
DRL71M4	M_{max}	Nm (lb in)		7 (62)	7 (62)		7 (62)						
	n_{base}	rpm		1763	1787		1787						
DRL80S4	M_{max}	Nm (lb in)			10 (89)	10 (89)	10 (89)	10 (89)					
	n_{base}	rpm			1957	2033	1927	2033					
DRL80M4	M_{max}	Nm (lb in)				14 (124)	11.9 (105)	14 (124)	14 (124)				
	n_{base}	rpm				1939	1816	1968	2109				
DRL90L4	M_{max}	Nm (lb in)							19.9 (176)	25 (221)	25 (221)		
	n_{base}	rpm							1863	1933	2121		
DRL100L4	M_{max}	Nm (lb in)								25.2 (223)	34.2 (303)	40 (354)	40 (354)
	n_{base}	rpm								2127	2003	1998	2044
DRL132S4	M_{max}	Nm (lb in)										46.8 (414)	72.2 (639)
	n_{base}	rpm										1909	1728

Assignment of MOVIDRIVE® MDX61B0150-503 ... MDX61B1600-503 (sizes 3 – 7):

Motor		MOVIDRIVE® MDX61B...-5_3 (AC 400/500 V units) in CFC operating modes (P700)											
		0150	0220	0300	0370	0450	0550	0750	0900	1100	1320	1600	
DRL132S4	M_{max}	Nm (lb in)	80 (708)										
	n_{base}	rpm	1713										
DRL132MC4	M_{max}	Nm (lb in)	94.8 (839)	130 (1151)	130 (1151)								
	n_{base}	rpm	1855	1787	1850								
DRL160M4	M_{max}	Nm (lb in)	93.4 (827)	137 (1213)	165 (1460)								
	n_{base}	rpm	1968	1810	1735								
DRL160MC4	M_{max}	Nm (lb in)		134 (1186)	178 (1575)	185 (1637)							
	n_{base}	rpm		1898	1775	1885							
DRL180S4	M_{max}	Nm (lb in)		140 (1239)	185 (1637)	210 (1859)	210 (1859)						
	n_{base}	rpm		1981	1880	1902	1964						
DRL180M4	M_{max}	Nm (lb in)		142 (1257)	190 (1682)	233 (2062)	250 (2213)	250 (2213)					
	n_{base}	rpm		1955	1885	1816	1915	1985					
DRL180L4	M_{max}	Nm (lb in)			187 (1655)	232 (2053)	287 (2540)	320 (2832)	320 (2832)				
	n_{base}	rpm			1912	1866	1799	1829	1955				
DRL180LC4	M_{max}	Nm (lb in)					274 (2425)	327 (2894)	409 (3620)	420 (3717)			
	n_{base}	rpm					1862	1806	1706	1812			
DRL200L4	M_{max}	Nm (lb in)				217 (1921)	269 (2381)	320 (2832)	399 (3531)	475 (4204)			
	n_{base}	rpm				2019	1957	1886	1777	1671			



Motor Selection

Motor selection for asynchronous AC and servomotors (CFC)

Motor			MOVIDRIVE® MDX61B...-5_3 (AC 400/500 V units) in CFC operating modes (P700)										
			0150	0220	0300	0370	0450	0550	0750	0900	1100	1320	1600
DRL225S4	M _{max}	Nm (lb in)						322 (2850)	405 (3585)	520 (4602)	520 (4602)		
	n _{base}	rpm						1960	1883	1795	1872		
DRL225MC4	M _{max}	Nm (lb in)								519 (4594)	618 (5470)	770 (6815)	770 (6815)
	n _{base}	rpm								1790	1725	1637	1681



Nominal speed $n_N = 2100$ rpm, dynamics package 2

Assignment of MOVIDRIVE® MDX61B0005-5A3 ... MDX61B0110-503 (sizes 0 – 2):

Motor		MOVIDRIVE® MDX61B...-5_3 (AC 400/500 V units) in CFC operating modes (P700)											
		0005	0008	0011	0014	0015	0022	0030	0040	0055	0075	0110	
DRL71S4	M_{max}	Nm	6	7.2	8.5		8.5						
		(lb in)	(53)	(64)	(75)		(75)						
	n_{base}	rpm	1582	1388	1207		1207						
DRL71M4	M_{max}	Nm		7.9	10.3	13.5	10	13.9	14				
		(lb in)		(69.9)	(91.2)	(119)	(88.5)	(123)	(124)				
	n_{base}	rpm		1611	1377	1089	1406	1054	1048				
DRL80S4	M_{max}	Nm			11.5	15.1	11.2	15.6	19.9	25			
		(lb in)			(102)	(134)	(99)	(138)	(176)	(221)			
	n_{base}	rpm			1728	1517	1752	1488	1230	949			
DRL80M4	M_{max}	Nm				16.4	11.9	17	21.9	30			
		(lb in)				(145)	(105)	(150)	(194)	(266)			
	n_{base}	rpm				1681	1816	1664	1505	1253			
DRL90L4	M_{max}	Nm							19.9	28.3	38	46	
		(lb in)							(176)	(250)	(336)	(407)	
	n_{base}	rpm							1863	1728	1558	1435	
DRL100L4	M_{max}	Nm								25.2	34.2	44.4	67.2
		(lb in)								(223)	(303)	(393)	(595)
	n_{base}	rpm								2127	2003	1851	1494
DRL132S4	M_{max}	Nm										46.8	72.2
		(lb in)										(414)	(639)
	n_{base}	rpm										1909	1728

Assignment of MOVIDRIVE® MDX61B0150-503 ... MDX61B2000-503 (sizes 3 – 7):

Motor		MOVIDRIVE® MDX61B...-5_3 (AC 400/500 V units) in CFC operating modes (P700)											
		0150	0220	0300	0370	0450	0550	0750	0900	1100	1320	1600	2000
DRL100L4	M_{max}	Nm	85										
		(lb in)	(752)										
	n_{base}	rpm	1242										
DRL132S4	M_{max}	Nm	97	140	150								
		(lb in)	(859)	(1239)	(1328)								
	n_{base}	rpm	1538	1235	1171								
DRL132MC4	M_{max}	Nm	94.8	139	183	200							
		(lb in)	(839)	(1230)	(1620)	(1770)							
	n_{base}	rpm	1855	1684	1508	1440							
DRL160M4	M_{max}	Nm	93.4	137	180	221	270	280					
		(lb in)	(827)	(1213)	(1593)	(1956)	(2390)	(2478)					
	n_{base}	rpm	1968	1810	1643	1494	1322	1287					
DRL160MC4	M_{max}	Nm		134	178	219	268	317	320				
		(lb in)		(1186)	(1575)	(1938)	(2372)	(2805)	(2832)				
	n_{base}	rpm		1898	1775	1661	1524	1393	1388				
DRL180S4	M_{max}	Nm		140	185	227	278	329	380				
		(lb in)		(1239)	(1637)	(2009)	(2461)	(2912)	(3363)				
	n_{base}	rpm		1981	1880	1784	1661	1538	1423				
DRL180M4	M_{max}	Nm		142	190	233	286	339	421	430			
		(lb in)		(1257)	(1681)	(2062)	(2531)	(3000)	(3721)	(3806)			
	n_{base}	rpm		1955	1885	1816	1723	1627	1480	1464			
DRL180L4	M_{max}	Nm			187	232	287	341	425	520			
		(lb in)			(1655)	(2053)	(2540)	(3018)	(3762)	(4602)			
	n_{base}	rpm			1912	1866	1799	1729	1620	1490			
DRL180LC4	M_{max}	Nm					274	327	409	539	600		
		(lb in)					(2425)	(2894)	(3620)	(4771)	(5310)		
	n_{base}	rpm					1862	1806	1710	1550	1474		



Motor Selection

Motor selection for asynchronous AC and servomotors (CFC)

Motor			MOVIDRIVE® MDX61B...-5_3 (AC 400/500 V units) in CFC operating modes (P700)											
			0150	0220	0300	0370	0450	0550	0750	0900	1100	1320	1600	2000
DRL200L4	M _{max}	Nm (lb in)				217 (1921)	269 (2381)	320 (2832)	399 (3531)	524 (4638)	618 (5470)	680 (6019)		
	n _{base}	rpm				2019	1957	1886	1777	1593	1468	1386		
DRL225S4	M _{max}	Nm (lb in)						322 (2850)	405 (3585)	535 (4735)	633 (5603)	770 (6815)		
	n _{base}	rpm						1960	1883	1752	1652	1511		
DRL225MC4	M _{max}	Nm (lb in)								519 (4594)	618 (5470)	780 (6904)	940 (8320)	1100 (9736)
	n _{base}	rpm								1790	1725	1617	1508	1403



Nominal speed $n_N = 3000$ rpm, dynamics package 1

Assignment of **MOVIDRIVE® MDX61B0005-5A3 ... MDX61B0110-503** (sizes 0 – 2):

Motor			MOVIDRIVE® MDX61B...-5_3 (AC 400/500 V units) in CFC operating modes (P700)										
			0005	0008	0011	0014	0015	0022	0030	0040	0055	0075	0110
DRL71S4	M_{max}	Nm (lb in)		5 (44.2)	5 (44.2)		5 (44.2)						
	n_{base}	rpm		2554	2654		2654						
DRL71M4	M_{max}	Nm (lb in)			7 (62)	7 (62)	7 (62)	7 (62)					
	n_{base}	rpm			2519	2630	2478	2630					
DRL80S4	M_{max}	Nm (lb in)				10 (89)	7.8 (69)	10 (89)	10 (89)				
	n_{base}	rpm				2794	2830	2841	3064				
DRL80M4	M_{max}	Nm (lb in)						11.8 (104)	14 (124)	14 (124)			
	n_{base}	rpm						2595	2424	3140			
DRL90L4	M_{max}	Nm (lb in)								19.8 (175)	25 (221)	25 (221)	
	n_{base}	rpm								2619	2677	3035	
DRL100L4	M_{max}	Nm (lb in)									24.1 (213)	31.8 (281)	40 (354)
	n_{base}	rpm									2988	2859	2912
DRL132S4	M_{max}	Nm (lb in)											50 (443)
	n_{base}	rpm											2710

Assignment of **MOVIDRIVE® MDX61B0150-503 ... MDX61B2500-503** (sizes 3 – 7):

Motor			MOVIDRIVE® MDX61B...-5_3 (AC 400/500 V units) in CFC operating modes (P700)												
			0150	0220	0300	0370	0450	0550	0750	0900	1100	1320	1600	2000	2500
DRL100L4	M_{max}	Nm (lb in)	40 (354)												
	n_{base}	rpm	2912												
DRL132S4	M_{max}	Nm (lb in)	68 (602)	80 (708)											
	n_{base}	rpm	2543	2558											
DRL132MC4	M_{max}	Nm (lb in)		96.4 (853)	128 (1133)	130 (1151)									
	n_{base}	rpm		2666	2504	2595									
DRL160M4	M_{max}	Nm (lb in)		97.6 (864)	129 (1142)	159 (1407)	165 (1460)								
	n_{base}	rpm		2733	2584	2439	2447								
DRL160MC4	M_{max}	Nm (lb in)			136 (1204)	168 (1487)	185 (1637)	185 (1637)	185 (1637)						
	n_{base}	rpm			2456	2351	2425	2460	2513						
DRL180S4	M_{max}	Nm (lb in)			132 (1168)	163 (1443)	200 (1770)	210 (1859)							
	n_{base}	rpm			2777	2693	2584	2720							
DRL180M4	M_{max}	Nm (lb in)				165 (1460)	204 (1806)	242 (2142)	250 (2213)	250 (2213)					
	n_{base}	rpm				2689	2613	2530	2755	2812					
DRL180L4	M_{max}	Nm (lb in)					205 (1814)	246 (2177)	308 (2726)	320 (2832)					
	n_{base}	rpm					2609	2553	2457	2722					
DRL180LC4	M_{max}	Nm (lb in)						227 (2009)	287 (2540)	381 (3372)	420 (3717)	420 (3717)			
	n_{base}	rpm						2702	2619	2477	2506	2593			



Motor Selection

Motor selection for asynchronous AC and servomotors (CFC)

Motor		MOVIDRIVE® MDX61B...-5_3 (AC 400/500 V units) in CFC operating modes (P700)												
		0150	0220	0300	0370	0450	0550	0750	0900	1100	1320	1600	2000	2500
DRL200L4	M _{max}	Nm (lb in)					224 (1983)	281 (2487)	372 (3292)	439 (3885)	475 (4204)			
	n _{base}	rpm					2835	2738	2570	2437	2375			
DRL225S4	M _{max}	Nm (lb in)						287 (2540)	383 (3390)	455 (4027)	520 (4602)	520 (4602)		
	n _{base}	rpm						2753	2639	2548	2543	2610		
DRL225MC4	M _{max}	Nm (lb in)									508 (4496)	618 (5470)	770 (6815)	770 (6815)
	n _{base}	rpm									2718	2619	2510	2630



Nominal speed $n_N = 3000$ rpm, dynamics package 2

Assignment of **MOVIDRIVE® MDX61B0005-5A3 ... MDX61B0110-503** (sizes 0 – 2):

Motor		MOVIDRIVE® MDX61B...-5_3 (AC 400/500 V units) in CFC operating modes (P700)										
		0005	0008	0011	0014	0015	0022	0030	0040	0055	0075	0110
DRL71S4	M_{max}	Nm (lb in)	5.1 (45)	6.7 (59)	8.5 (75)	6.5 (57)	8.5 (75)					
	n_{base}	rpm	2502	2185	1869	2232	1869					
DRL71M4	M_{max}	Nm (lb in)		7.3 (65)	9.6 (85)	7 (62)	9.9 (88)	12.7 (112)	14 (124)			
	n_{base}	rpm		2443	2162	2478	2127	1798	1664			
DRL80S4	M_{max}	Nm (lb in)			10.7 (95)	7.8 (69)	11 (97)	14.2 (126)	19.5 (173)	25 (221)		
	n_{base}	rpm			2630	2830	2607	2378	2003	1634		
DRL80M4	M_{max}	Nm (lb in)					11.8 (104)	15.5 (137)	21.6 (191)	28.7 (254)	30 (266)	
	n_{base}	rpm					2595	2472	2250	1986	1933	
DRL90L4	M_{max}	Nm (lb in)							19.8 (175)	27.1 (240)	35.5 (314)	46 (407)
	n_{base}	rpm							2619	2478	2314	2121
DRL100L4	M_{max}	Nm (lb in)								24.1 (213)	31.8 (281)	48.8 (432)
	n_{base}	rpm								2988	2859	2537
DRL132S4	M_{max}	Nm (lb in)										50 (443)
	n_{base}	rpm										2710

Assignment of **MOVIDRIVE® MDX61B0150-503 ... MDX61B2500-503** (sizes 3 – 7):

Motor		MOVIDRIVE® MDX61B...-5_3 (AC 400/500 V units) in CFC operating modes (P700)												
		0150	0220	0300	0370	0450	0550	0750	0900	1100	1320	1600	2000	2500
DRL100L4	M_{max}	Nm (lb in)	65.5 (580)	85 (752)										
	n_{base}	rpm	2209	1851										
DRL132S4	M_{max}	Nm (lb in)	68 (602)	98.9 (875)	129 (1142)	150 (1328)								
	n_{base}	rpm	2543	2236	1943	1762								
DRL132MC4	M_{max}	Nm (lb in)		96.4 (853)	128 (1133)	157 (1390)	192 (1922)	200 (1770)						
	n_{base}	rpm		2666	2504	2348	2163	2119						
DRL160M4	M_{max}	Nm (lb in)		97.6 (864)	129 (1142)	159 (1407)	194 (1717)	230 (2036)	280 (2478)					
	n_{base}	rpm		2733	2584	1439	2254	2078	1850					
DRL160MC4	M_{max}	Nm (lb in)			136 (1204)	168 (1487)	207 (1832)	245 (2168)	305 (2699)	320 (2832)				
	n_{base}	rpm			2456	2351	2214	2078	1872	1828				
DRL180S4	M_{max}	Nm (lb in)			132 (1168)	163 (1443)	200 (1770)	210 (1859)	238 (2106)	296 (2620)	380 (3363)			
	n_{base}	rpm			2777	2693	2584	2720	2469	2285	2025			
DRL180M4	M_{max}	Nm (lb in)				165 (1460)	204 (1806)	242 (2142)	302 (2673)	398 (3523)	430 (3806)			
	n_{base}	rpm				2689	2613	2530	2393	2168	2091			
DRL180L4	M_{max}	Nm (lb in)					205 (1814)	246 (2177)	308 (2726)	407 (3602)	481 (4257)	520 (4602)		
	n_{base}	rpm					2609	2553	2457	2287	2158	2091		
DRL180LC4	M_{max}	Nm (lb in)						227 (2009)	287 (2540)	381 (3372)	451 (3992)	567 (5018)	600 (5310)	
	n_{base}	rpm						2702	2619	2477	2364	2174	2118	



Motor Selection

Motor selection for asynchronous AC and servomotors (CFC)

Motor		MOVIDRIVE® MDX61B...-5_3 (AC 400/500 V units) in CFC operating modes (P700)												
		0150	0220	0300	0370	0450	0550	0750	0900	1100	1320	1600	2000	2500
DRL200L4	M _{max}	Nm					224	281	372	439	551	662	680	
		(lb in)					(1983)	(2487)	(3292)	(3885)	(4877)	(5859)	(6019)	
	n _{base}	rpm					2835	2738	2570	2437	2218	2015	1984	
DRL225S4	M _{max}	Nm						287	383	455	574	691	770	
		(lb in)						(2540)	(3390)	(4027)	(5080)	(6116)	(6815)	
	n _{base}	rpm						2753	2639	2548	2387	2223	2115	
DRL225MC4	M _{max}	Nm									508	618	791	985
		(lb in)									(4496)	(5470)	(7001)	(8718)
	n _{base}	rpm									2718	2619	2452	2261



8.3.9 Motor table DRS series AC motors (characteristic value with delta/star connection AC 230/400 V / 50 Hz)

Motor	P _m kW	M _N Nm (lb in)	Mass moment of inertia J _M without brake with brake 10 ⁻⁴ kgm ²		Star \star (AC 400 V)				Delta Δ (AC 230 V)			
			I _n A	I _{q,n} ⁽¹⁾ A	I _{d,n} ⁽¹⁾ A	k _T ⁽¹⁾ Nm/A (lb in/A)	I _n A	I _{q,n} ⁽¹⁾ A	I _{d,n} ⁽¹⁾ A	k _T Nm/A (lb in/A)		
DRS71S4	0.37	2.55 (23)	4.9	6.2	1.14	0.91	0.68	2.79 (24.7)	1.97	1.58	1.18	1.61 (14.2)
DRS71M4	0.55	3.8 (34)	7.1	8.4	1.55	1.23	0.95	3.10 (27.4)	2.68	2.12	1.64	1.79 (15.8)
DRS80S4	0.75	5.1 (45)	14.9	16.4	1.8	1.54	0.93	3.31 (29.3)	3.1	2.67	1.61	1.91 (16.9)
DRS80M4	1.1	7.4 (65)	21.5	26	2.4	2.09	1.19	3.55 (31.4)	4.2	3.6	2.1	2.05 (18.1)
DRS90M4	1.5	10.3 (91)	35.5	40	3.3	3.00	1.39	3.44 (30.4)	5.7	5.2	2.4	1.99 (17.6)
DRS90L4	2.2	15 (133)	43.5	49.5	4.85	4.11	2.57	3.65 (32.3)	8.4	7.1	4.4	2.10 (18.6)
DRS100M4	3	20.5 (181)	56	62	6.4	5.91	2.45	3.47 (30.7)	11.1	10.2	4.2	2.00 (17.7)
DRS100LC4	4	26.5 (235)	90	96	8.4	7.55	3.67	3.51 (31.1)	14.5	13.1	6.4	2.03 (18.0)
DRS112M4	4	26.5 (235)	146	151	8.1	7.71	2.49	3.44 (30.4)	14.0	13.4	4.3	1.98 (17.5)
DRS132S4	5.5	36.5 (323)	190	200	11.1	10.3	4.18	3.55 (31.4)	19.2	17.8	7.2	2.05 (18.1)
DRS132M4	7.5	49.5 (438)	255	265	14.4	13.6	4.64	3.63 (32.1)	24.9	23.6	8.0	2.10 (18.6)
DRS132MC4	9.2	60 (531)	340	355	18.6	16.6	8.29	3.60 (31.9)	32.2	28.8	14.4	2.08 (18.4)
DRS160S4	9.2	60 (531)	370	420	18.9	16.8	8.75	3.58 (31.7)	32.7	29.1	15.2	2.07 (18.3)
DRS160M4	11	72 (637)	450	500	22	20.1	8.94	3.58 (31.7)	38.1	34.8	15.5	2.07 (18.3)
DRS160MC4	15	94 (832)	590	640	30	27.8	11.8	3.38 (29.9)	52.0	48.1	20.5	1.95 (17.3)
DRS180S4	15	98 (867)	900	960	29	26.4	11.7	3.71 (32.8)	50.2	45.7	20.3	2.14 (18.9)
DRS180M4	18.5	121 (1071)	1110	1250	34.5	32.0	12.7	3.78 (33.5)	59.8	55.4	21.9	2.18 (19.3)
DRS180L4	22	143 (1266)	1300	1440	41.5	37.5	17.3	3.81 (33.7)	71.9	64.9	29.9	2.20 (19.5)
DRS180LC4	30	195 (1726)	1680	1910	57	52.6	21.2	3.71 (32.8)	98.7	91.1	36.7	2.14 (18.9)
DRS200L4	30	194 (1717)	2360	2590	57	53.2	20.6	3.64 (32.2)	98.7	92.2	35.7	2.10 (18.6)
DRS225S4	37	240 (2124)	2930	3160	70	64.8	25.2	3.70 (32.7)	121	112	43.7	2.14 (18.9)
DRS225M4	45	290 (2567)	3430	3660	84	76.2	35.1	3.80 (33.6)	145	132	60.8	2.20 (19.5)
DRS225MC4	55	355 (3142)	4330	4560	105	97.6	38.7	3.64 (32.2)	182	169	67.1	2.10 (18.6)
DRS315K4	110	710 (6284)	18400	19500	200	185	75.9	3.84 (34.0)	345	321	131	2.22 (19.6)
DRS315S4	132	850 (7523)	22500	23600	245 ⁽²⁾	212	94.7	4.01 (35.5)	425	367	164	2.32 (20.5)



Motor Selection

Motor selection for asynchronous AC and servomotors (CFC)

Motor	P _m kW	M _N Nm (lb in)	Mass moment of inertia J _M without brake with brake 10 ⁻⁴ kgm ²		Star \star (AC 400 V)				Delta Δ (AC 230 V)			
			I _n A	I _{q_n} ¹⁾ A	I _{d_n} ¹⁾ A	k _T ¹⁾ Nm/A (lb in/A)	I _n A	I _{q_n} ¹⁾ A	I _{d_n} ¹⁾ A	k _T Nm/A (lb in/A)		
DRS315M4	160	1030 (9116)	27900	29000	280	262	97.4	3.92 (34.7)	485	455	169	2.27 (20.1)
DRS315L4	200	1290 (11417)	31900	33000	350	330	117	3.91 (34.6)	-	-	-	-

1) Applies in the basic speed range up to n_{base}.

2) Current ratings for 230/400 V winding. Due to the number of turns, the current of the 400/690 V winding is 235 A.



8.3.10 DRS motor selection with delta/star connection type (line AC 400 V / 50 Hz)

AC 230/400 V / 50 Hz motors in star connection or AC 400/690 V / 50 Hz motors in delta connection

Assignment of MOVIDRIVE® MDX61B0005-5A3 ... MDX61B0110-503 (sizes 0 ... 2):

Motor voltage			MOVIDRIVE® MDX61B...-5_3 (AC 400/500 V units) in CFC operating modes (P700)										
AC 400 / 50 Hz			0005	0008	0011	0014	0015	0022	0030	0040	0055	0075	0110
DRS71S4	M _{max}	Nm (lb in)	10 (89)				10 (89)						
	n _{base}	rpm	375				375						
DRS71M4	M _{max}	Nm (lb in)	10 (89)				10 (89)						
	n _{base}	rpm	685				685						
DRS80S4	M _{max}	Nm (lb in)	12.9 (114)	14 (124)			14 (124)						
	n _{base}	rpm	761	703			704						
DRS80M4	M _{max}	Nm (lb in)	13.6 (120)	14 (124)	14 (124)		14 (124)						
	n _{base}	rpm	960	1031	1066		1066						
DRS90M4	M _{max}	Nm (lb in)			20.7 (183)	27 (240)	20 (177)	27.9 (247)	28 (248)				
	n _{base}	rpm			925	791	943	774	767				
DRS90L4	M _{max}	Nm (lb in)				27.6 (244)	19.8 (175)	28.6 (253)	37.1 (328)	40 (354)			
	n _{base}	rpm				925	1019	914	808	785			
DRS100M4	M _{max}	Nm (lb in)						27.3 (242)	35.3 (312)	40 (354)			
	n _{base}	rpm						1113	1037	1066			
DRS100LC4	M _{max}	Nm (lb in)							34.4 (304)	48.2 (427)	55 (487)	55 (487)	
	n _{base}	rpm							1166	1095	1148	1212	
DRS112M4	M _{max}	Nm (lb in)							35.2 (312)	48.4 (428)	55 (487)		
	n _{base}	rpm							1152	1059	1040		
DRS132S4	M _{max}	Nm (lb in)								48.2 (427)	64.6 (572)	83.5 (739)	110 (974)
	n _{base}	rpm								1093	1025	942	825
DRS132M4	M _{max}	Nm (lb in)									66.1 (585)	85.6 (758)	110 (974)
	n _{base}	rpm									1079	1015	976
DRS132MC4	M _{max}	Nm (lb in)										81.1 (718)	126 (1115)
	n _{base}	rpm										1103	1005
DRS160S4	M _{max}	Nm (lb in)										80.2 (710)	125 (1106)
	n _{base}	rpm										1063	980
DRS160M4	M _{max}	Nm (lb in)											124 (1097)
	n _{base}	rpm											1067
DRS160MC4	M _{max}	Nm (lb in)											119 (1053)
	n _{base}	rpm											1160
DRS180S4	M _{max}	Nm (lb in)											126 (1115)
	n _{base}	rpm											1092

Note:

The data is based on a line voltage of AC 400 V.



Motor Selection

Motor selection for asynchronous AC and servomotors (CFC)

Assignment of MOVIDRIVE® MDX61B0150-503 ... MDX61B0750-503 (size 3 ... 5):

Motor voltage			MOVIDRIVE® MDX61B...-5_3 (AC 400/500 V units) in CFC operating modes (P700)						
AC 400 / 50 Hz			0150	0220	0300	0370	0450	0550	0750
DRS132S4	M _{max}	Nm (lb in)	110 (974)						
	n _{base}	rpm	825						
DRS132M4	M _{max}	Nm (lb in)	110 (974)						
	n _{base}	rpm	976						
DRS132MC4	M _{max}	Nm (lb in)	170 (1505)	200 (1770)					
	n _{base}	rpm	903	844					
DRS160S4	M _{max}	Nm (lb in)	169 (1496)	200 (1770)					
	n _{base}	rpm	892	852					
DRS160M4	M _{max}	Nm (lb in)	168 (1487)	200 (1770)	200 (1770)				
	n _{base}	rpm	984	958	958				
DRS160MC4	M _{max}	Nm (lb in)	163 (1443)	200 (1770)	200 (1770)	200 (1770)			
	n _{base}	rpm	1107	1164	1204	1204			
DRS180S4	M _{max}	Nm (lb in)	172 (1522)	200 (1770)	200 (1770)				
	n _{base}	rpm	1029	1079	1079				
DRS180M4	M _{max}	Nm (lb in)	174 (1540)	255 (2257)	335 (2965)	400 (3540)	400 (3540)		
	n _{base}	rpm	1069	979	886	810	810		
DRS180L4	M _{max}	Nm (lb in)	171 (1513)	255 (2257)	337 (2983)	400 (3540)	400 (3540)		
	n _{base}	rpm	1085	1022	952	909	929		
DRS180LC4	M _{max}	Nm (lb in)		243 (2151)	324 (2868)	397 (3514)	488 (4319)	578 (5116)	600 (5310)
	n _{base}	rpm		1065	1009	949	879	810	793
DRS200L4	M _{max}	Nm (lb in)		241 (2133)	320 (2832)	393 (3478)	482 (4266)	570 (5045)	600 (5310)
	n _{base}	rpm		1081	1022	963	890	820	796
DRS225S4	M _{max}	Nm (lb in)			319 (2823)	393 (3478)	484 (4284)	574 (5080)	600 (5310)
	n _{base}	rpm			1110	1066	1010	962	934
DRS225M4	M _{max}	Nm (lb in)				394 (3487)	490 (4337)	584 (5169)	600 (5310)
	n _{base}	rpm				1092	1054	1013	1092
DRS225MC4	M _{max}	Nm (lb in)					464 (4107)	555 (4912)	695 (6151)
	n _{base}	rpm					1037	996	931

Note:

The data is based on a line voltage of AC 400 V.



Assignment of MOVIDRIVE® MDX61B0900-503 ... MDX61B2500-503 (sizes 6 ... 7):

Motor voltage			MOVIDRIVE® MDX61B...-5_3 (AC 400/500 V units) in CFC operating modes (P700)					
AC 400 / 50 Hz			0900	1100	1320	1600	2000	2500
DRS225MC4	M _{max}	Nm (lb in)	914 (8090)	1079 (9550)	1200 (10621)			
	n _{base}	rpm	832	758	709			
DRS315K4	M _{max}	Nm (lb in)	932 (8249)	1111 (9833)	1406 (12444)	1600 (14161)	1600 (14161)	1600 (14161)
	n _{base}	rpm	1053	1041	1015	1046	1198	1221
DRS315S4	M _{max}	Nm (lb in)		1141 (10099)	1455 (12878)	1600 (14161)	1600 (14161)	1600 (14161)
	n _{base}	rpm		1074	1056	1142	1360	1482
DRS315M4	M _{max}	Nm (lb in)			1421 (12577)	1724 (15259)	2204 (19507)	2400 (21242)
	n _{base}	rpm			1010	997	972	1061
DRS315L4	M _{max}	Nm (lb in)	Note: The data is based on a line voltage of AC 400 V.			1699 (15037)	2181 (19303)	2400 (21242)
	n _{base}	rpm				1002	985	1081



Motor Selection

Motor selection for asynchronous AC and servomotors (CFC)

AC 230/400 V / 50 Hz motors in delta connection

Assignment of MOVIDRIVE® MDX61B0005-5A3 ... MDX61B0110-503 (sizes 0 ... 2):

Motor voltage			MOVIDRIVE® MDX61B...-5_3 (AC 400/500 V units) in CFC operating modes (P700)										
AC 230 / 50 Hz			0005	0008	0011	0014	0015	0022	0030	0040	0055	0075	0110
DRS71S4	M _{max}	Nm (lb in)	6.2 (55)	7.5 (66)	9.8 (87)	10 (89)	9.4 (83)	10 (89)					
	n _{base}	rpm	1669	1494	1201	1171	1242	1171					
DRS71M4	M _{max}	Nm (lb in)		8 (71)	10 (89)		10 (89)						
	n _{base}	rpm		1687	1564		1546						
DRS80S4	M _{max}	Nm (lb in)			11.4 (101)	14 (124)	11 (97)	14 (124)					
	n _{base}	rpm			1757	1658	1781	1669					
DRS80M4	M _{max}	Nm (lb in)				14 (124)	11.6 (103)	14 (124)	14 (124)				
	n _{base}	rpm				2050	1962	2091	2285				
DRS90M4	M _{max}	Nm (lb in)						15.6 (138)	20.1 (178)	27.7 (245)	28 (248)		
	n _{base}	rpm						1980	1857	1646	1658		
DRS90L4	M _{max}	Nm (lb in)						19.9 (176)	28.4 (251)	38.2 (338)	40 (354)		
	n _{base}	rpm						1921	1798	1646	1734		
DRS100M4	M _{max}	Nm (lb in)							27.1 (240)	36.3 (321)	40 (354)	40 (354)	
	n _{base}	rpm							2080	1968	2103	2191	
DRS100LC4	M _{max}	Nm (lb in)								35.5 (314)	46.5 (412)	55 (487)	
	n _{base}	rpm								2121	2044	2302	
DRS112M4	M _{max}	Nm (lb in)								36.2 (320)	46.8 (412)	55 (487)	
	n _{base}	rpm								2094	1987	2016	
DRS132S4	M _{max}	Nm (lb in)										46.5 (412)	71.7 (635)
	n _{base}	rpm										1997	1845
DRS132M4	M _{max}	Nm (lb in)											73.4 (650)
	n _{base}	rpm											1923

Assignment of MOVIDRIVE® MDX61B0150-503 ... MDX61B0750-503 (size 3 ... 5):

Motor voltage			MOVIDRIVE® MDX61B...-5_3 (AC 400/500 V units) in CFC operating modes (P700)						
AC 230 / 50 Hz			0150	0220	0300	0370	0450	0550	0750
DRS100LC4	M _{max}	Nm (lb in)	55 (487)						
	n _{base}	rpm	2361						
DRS132S4	M _{max}	Nm (lb in)	96.4 (853)	110 (974)					
	n _{base}	rpm	1684	1596					
DRS132M4	M _{max}	Nm (lb in)	98.9 (875)	110 (974)					
	n _{base}	rpm	1806	1855					



Motor voltage			MOVIDRIVE® MDX61B...-5_3 (AC 400/500 V units) in CFC operating modes (P700)						
AC 230 / 50 Hz			0150	0220	0300	0370	0450	0550	0750
DRS132MC4	M _{max}	Nm	94.8	139	184	200			
		(lb in)	(839)	(1230)	(1629)	(1770)			
	n _{base}	rpm	1943	1806	1655	1616			
DRS160S4	M _{max}	Nm	93.9	138	183	200			
		(lb in)	(831)	(1221)	(1620)	(1770)			
	n _{base}	rpm	1880	1762	1639	1643			
DRS160M4	M _{max}	Nm	93.5	138	182	200			
		(lb in)	(828)	(1221)	(1611)	(1770)			
	n _{base}	rpm	2012	1902	1779	1801			
DRS160MC4	M _{max}	Nm		132	176	200	200		
		(lb in)		(1168)	(1558)	(1770)	(1770)		
	n _{base}	rpm		2056	1977	2043	2232		
DRS180S4	M _{max}	Nm		140	187	200	200		
		(lb in)		(1239)	(1655)	(1770)	(1770)		
	n _{base}	rpm		1932	1836	1949	2032		
DRS180M4	M _{max}	Nm		141	189	232	285	338	400
		(lb in)		(1248)	(1673)	(2053)	(2522)	(2992)	(3540)
	n _{base}	rpm		1965	1895	1822	1733	1636	1524
DRS180L4	M _{max}	Nm			186	231	286	340	400
		(lb in)			(1646)	(2045)	(2531)	(3009)	(3540)
	n _{base}	rpm			1922	1872	1809	1739	1700
DRS180LC4	M _{max}	Nm					273	326	407
		(lb in)					(2416)	(2885)	(3602)
	n _{base}	rpm					1872	1812	1716
DRS200L4	M _{max}	Nm					270	322	403
		(lb in)					(2390)	(2850)	(3567)
	n _{base}	rpm					1889	1825	1722
DRS225S4	M _{max}	Nm						321	403
		(lb in)						(2841)	(3567)
	n _{base}	rpm					1968	1892	
DRS225M4	M _{max}	Nm							405
		(lb in)							(3585)
	n _{base}	rpm						1927	

Assignment of MOVIDRIVE® MDX61B0900-503 ... MDX61B2500-503 (sizes 6 ... 7):

Motor voltage			MOVIDRIVE® MDX61B...-5_3 (AC 400/500 V units) in CFC operating modes (P700)						
AC 230 / 50 Hz			0900	1100	1320	1600	2000	2500	
DRS180LC4	M _{max}	Nm	537	600					
		(lb in)	(4753)	(5310)					
	n _{base}	rpm	1557	1480					
DRS200L4	M _{max}	Nm	530	600					
		(lb in)	(4691)	(5310)					
	n _{base}	rpm	1555	1467					
DRS225S4	M _{max}	Nm	533	600					
		(lb in)	(4717)	(5310)					
	n _{base}	rpm	1760	1719					
DRS225M4	M _{max}	Nm	542	600	600				
		(lb in)	(4797)	(5310)	(5310)				
	n _{base}	rpm	1839	1878	1968				
DRS225MC4	M _{max}	Nm	514	611	771	936	1192	1200	
		(lb in)	(4549)	(5408)	(6824)	(8284)	(10550)	(10621)	
	n _{base}	rpm	1804	1734	1614	1517	1350	1344	



Motor Selection

Motor selection for asynchronous AC and servomotors (CFC)

Motor voltage			MOVIDRIVE® MDX61B...-5_3 (AC 400/500 V units) in CFC operating modes (P700)					
AC 230 / 50 Hz			0900	1100	1320	1600	2000	2500
DRS315K4	M_{max}	Nm (lb in)				947 (8382)	1221 (10807)	1525 (13497)
	n_{base}	rpm				1856	1823	1782
DRS315S4	M_{max}	Nm (lb in)					1258 (11134)	1580 (13984)
	n_{base}	rpm					1881	1856
DRS315M4	M_{max}	Nm (lb in)					1228 (10869)	1544 (13666)
	n_{base}	rpm					1792	1772
DRS315L4	M_{max}	Nm (lb in)						1517 (13427)
	n_{base}	rpm						1774



8.3.11 DRS motor selection in delta connection type (line AC 230 V / 50 Hz)

AC 230/400 V / 50 Hz motors in delta connection

Motor voltage			MOVIDRIVE® MDX61B...-2_3 (AC 230 V units) in CFC operating modes (P700)								
AC 230 V / 50 Hz			0015	0022	0037	0055	0075	0110	0150	0220	0300
DRS71M4 0.37 kW	M _{max}	Nm (lb in)	10 (89)								
	n _{base}	rpm	263								
DRS71M4	M _{max}	Nm (lb in)	10 (89)								
	n _{base}	rpm	685								
DRS80S4	M _{max}	Nm (lb in)	14 (124)								
	n _{base}	rpm	703								
DRS80M4	M _{max}	Nm (lb in)	14 (124)								
	n _{base}	rpm	1066								
DRS90M4	M _{max}	Nm (lb in)	21.1 (187)	25 (221)	28 (248)						
	n _{base}	rpm	919	832	767						
DRS90L4	M _{max}	Nm (lb in)	21 (186)	25.4 (225)	40 (354)						
	n _{base}	rpm	1007	955	779						
DRS100M4	M _{max}	Nm (lb in)		24.2 (214)	40 (354)	40 (354)					
	n _{base}	rpm		1142	1025	1072					
DRS100LC4	M _{max}	Nm (lb in)			41.8 (370)	55 (487)	55 (487)				
	n _{base}	rpm			1130	1154	1212				
DRS112M4	M _{max}	Nm (lb in)			42.3 (374)	55 (487)					
	n _{base}	rpm			1103	1040					
DRS132S4	M _{max}	Nm (lb in)			41.7 (369)	65.4 (579)	87.2 (772)	110 (974)			
	n _{base}	rpm			1118	1020	927	825			
DRS132M4	M _{max}	Nm (lb in)				66.9 (592)	89.4 (791)	110 (974)			
	n _{base}	rpm				1074	1001	976			
DRS132MC4	M _{max}	Nm (lb in)					85 (752)	127 (1124)	165 (1460)	200 (1770)	
	n _{base}	rpm					1093	1001	918	844	
DRS160S4	M _{max}	Nm (lb in)					84.1 (744)	126 (1115)	164 (1452)	200 (1770)	
	n _{base}	rpm					1054	980	905	852	
DRS160M4	M _{max}	Nm (lb in)					83.6 (740)	125 (1106)	163 (1443)	200 (1770)	
	n _{base}	rpm					1138	1067	993	958	
DRS160MC4	M _{max}	Nm (lb in)						120 (1062)	158 (1398)	200 (1770)	200 (1770)
	n _{base}	rpm						1160	1111	1164	1204
DRS180S4	M _{max}	Nm (lb in)						127 (1124)	167 (1478)	200 (1770)	
	n _{base}	rpm						1092	1035	1079	
DRS180M4	M _{max}	Nm (lb in)							169 (1496)	255 (2257)	305 (2699)
	n _{base}	rpm							1075	979	923

Note:
The data is based on a line voltage of AC 230 V.



Motor Selection

Motor selection for asynchronous AC and servomotors (CFC)

Motor voltage			MOVIDRIVE® MDX61B...-2_3 (AC 230 V units) in CFC operating modes (P700)									
AC 230 V / 50 Hz			0015	0022	0037	0055	0075	0110	0150	0220	0300	
DRS180L4	M_{max}	Nm (lb in)								255 (2257)	306 (2708)	
	n_{base}	rpm								1022	979	
DRS180LC4	M_{max}	Nm (lb in)								243 (2151)	293 (2593)	
	n_{base}	rpm								1065	1029	
DRS200L4	M_{max}	Nm (lb in)								241 (2133)	290 (2567)	
	n_{base}	rpm								1081	1045	
DRS225S4	M_{max}	Nm (lb in)	Note: The data is based on a line voltage of AC 230 V.									288 (2549)
	n_{base}	rpm										



8.3.12 Motor table DRE series AC motors (characteristic value with delta/star connection AC 230/400 V / 50 Hz)

Motor	P _m kW	M _N Nm (lb in)	Mass moment of inertia J _M		Star \star (AC 400 V)				Delta Δ (AC 230 V)			
			without brake	with brake	I _n	I _{q_n} ¹⁾	I _{d_n} ¹⁾	k _T ¹⁾	I _n	I _{q_n} ¹⁾	I _{d_n} ¹⁾	k _T ¹⁾
			10 ⁻⁴ kgm ²		A	A	A	Nm/A (lb in/A)	A	A	A	Nm/A (lb in/A)
DRE80M4	0.75	5 (44)	21.5	23	1.68	1.37	0.98	3.66 (32.4)	2.91	2.37	1.69	2.11 (18.7)
DRE90M4	1.1	7.4 (65)	35.5	40	2.45	2.15	1.18	3.45 (30.5)	4.24	3.72	2.04	1.99 (17.6)
DRE90L4	1.5	10 (89)	43.5	48.5	3.35	2.64	2.06	3.78 (33.5)	5.80	4.58	3.56	2.18 (19.3)
DRE100M4	2.2	14.7 (130)	56	62	4.6	4.16	1.96	3.53 (31.2)	8.0	7.21	3.40	2.04 (18.1)
DRE100LC4	3	19.7 (174)	90	96	6.2	5.52	2.81	3.57 (31.6)	10.7	9.57	4.87	2.06 (18.2)
DRE112M4	3	19.7 (174)	146	151	6	5.51	2.38	3.58 (31.7)	10.4	9.54	4.12	2.07 (18.3)
DRE132S4	4	26 (230)	190	195	8	7.35	3.17	3.54 (31.3)	13.9	12.7	5.5	2.04 (18.1)
DRE132M4	5.5	36 (319)	255	265	10.5	9.91	3.48	3.63 (32.1)	18.2	17.2	6.0	2.10 (18.6)
DRE132MC4	7.5	48.5 (429)	340	355	14.8	13.4	6.31	3.62 (32.0)	25.6	23.2	10.9	2.09 (18.5)
DRE160S4	7.5	49 (434)	370	390	14.7	13.3	6.29	3.68 (32.6)	25.5	23.0	10.9	2.13 (18.9)
DRE160M4	9.2	60 (531)	450	500	18.3	16.2	8.41	3.70 (32.7)	31.7	28.1	14.6	2.13 (18.9)
DRE160MC4	11	71 (628)	590	640	21.5	20.1	8.10	3.53 (31.2)	37	34.9	14.0	2.04 (18.1)
DRE180S4	11	71 (628)	895	955	21	18.7	9.26	3.79 (33.5)	36	32.5	16.0	2.19 (19.4)
DRE180M4	15	97 (859)	1110	1170	28	25.9	10.4	3.75 (33.2)	48	44.8	18.1	2.17 (19.2)
DRE180L4	18.5	120 (1062)	1300	1440	34	31.2	14.1	3.85 (34.1)	59	54.0	24.4	2.22 (19.6)
DRE180LC4	22	142 (1257)	1680	1815	42	36.3	20.8	3.91 (34.6)	73	62.8	36.0	2.26 (20.0)
DRE200L4	22	194 (1717)	2360	2500	57	53.6	19.4	3.62 (32.0)	99	92.8	33.6	2.09 (18.5)
DRE225S4	30	240 (2124)	2930	3160	70	65.1	25.7	3.69 (32.7)	121	113	44.5	2.13 (18.9)
DRE225M4	37	290 (2567)	3430	3660	84	78.3	30.5	3.70 (32.7)	145	136	52.9	2.14 (18.9)
DRE315K4	110	708 (6266)	18400	19500	196	183	69.6	3.86 (34.2)	340	317	121	2.23 (19.7)
DRE315S4	132	850 (7523)	22500	23600	2301)	208	95.6	4.08 (36.1)	425	360	166	2.36 (20.9)
DRE315M4	160	1030 (9116)	27900	29000	275	260	88.8	3.96 (35.0)	480	451	154	2.28 (20.2)
DRE315L4	200	1289 (11409)	31900	33000	345	328	106	3.93 (34.8)	-	-	-	-

1) Applies in the basic speed range up to n_{base}.



Motor Selection

Motor selection for asynchronous AC and servomotors (CFC)

8.3.13 DRE motor selection with delta/star connection type (line AC 400 V / 50 Hz)

AC 230/400 V / 50 Hz motors in star connection or AC 400/690 V / 50 Hz motors in delta connection

Assignment of MOVIDRIVE® MDX61B0005-5A3 ... MDX61B0110-503 (sizes 0 ... 2):

Motor voltage			MOVIDRIVE® MDX61B...-5_3 (AC 400/500 V units) in CFC operating modes (P700)										
AC 400 / 50 Hz			0005	0008	0011	0014	0015	0022	0030	0040	0055	0075	0110
DRE80M4	M_{max}	Nm (lb in)	14 (124)	14 (124)			14 (124)						
	n_{base}	rpm	849	884			890						
DRE90M4	M_{max}	Nm (lb in)	13.2 (117)	14 (124)	14 (124)		14 (124)						
	n_{base}	rpm	990	1037	1084		1084						
DRE90L4	M_{max}	Nm (lb in)			22.2 (196)	28 (248)	21.4 (189)	28 (248)	28 (248)				
	n_{base}	rpm			902	837	914	843	867				
DRE100M4	M_{max}	Nm (lb in)				27.5 (243)	20.1 (178)	28.4 (251)	36.6 (324)	40 (354)			
	n_{base}	rpm				1048	1125	1037	943	931			
DRE100LC4	M_{max}	Nm (lb in)						27.6 (244)	36.1 (320)	40 (354)	40 (354)		
	n_{base}	rpm						1113	1060	1166	1212		
DRE112M4	M_{max}	Nm (lb in)						28.2 (250)	36.6 (324)	40 (354)			
	n_{base}	rpm						1084	1020	1074			
DRE132S4	M_{max}	Nm (lb in)							35.7 (316)	49.5 (438)	55 (487)	55 (487)	
	n_{base}	rpm							1113	1044	1103	1123	
DRE132M4	M_{max}	Nm (lb in)								50.4 (446)	67.1 (593)	86.5 (766)	110 (974)
	n_{base}	rpm								1079	1015	932	830
DRE132MC4	M_{max}	Nm (lb in)									64.3 (569)	84.3 (746)	110 (974)
	n_{base}	rpm									1103	1059	1079
DRE160S4	M_{max}	Nm (lb in)									64.9 (574)	8501 (75240)	110 (974)
	n_{base}	rpm									1098	1050	1072
DRE160M4	M_{max}	Nm (lb in)										82.7 (731)	128 (1133)
	n_{base}	rpm										1103	1019
DRE160MC4	M_{max}	Nm (lb in)											124 (1097)
	n_{base}	rpm											1129
DRE180S4	M_{max}	Nm (lb in)											132 (1168)
	n_{base}	rpm											1026
DRE180M4	M_{max}	Nm (lb in)											129 (1142)
	n_{base}	rpm											1092

Note:

The data is based on a line voltage of AC 400 V.



Assignment of MOVIDRIVE® MDX61B0150-503 ... MDX61B0750-503 (size 3 ... 5):

Motor voltage			MOVIDRIVE® MDX61B...-5_3 (AC 400/500 V units) in CFC operating modes (P700)						
AC 400 / 50 Hz			0150	0220	0300	0370	0450	0550	0750
DRE160M4	M _{max}	Nm (lb in)	174 (1540)	200 (1770)					
	n _{base}	rpm	931	900					
DRE160MC4	M _{max}	Nm (lb in)	167 (1478)	200 (1770)					
	n _{base}	rpm	1059	1072					
DRE180S4	M _{max}	Nm (lb in)	179 (1584)	200 (1770)					
	n _{base}	rpm	946	946					
DRE180M4	M _{max}	Nm (lb in)	176 (1558)	200 (1770)					
	n _{base}	rpm	1035	1115					
DRE180L4	M _{max}	Nm (lb in)	176 (1558)	260 (2301)	342 (3027)	400 (3540)			
	n _{base}	rpm	1035	962	883	830			
DRE180LC4	M _{max}	Nm (lb in)		257 (2275)	342 (3027)	400 (3540)			
	n _{base}	rpm		959	899	873			
DRE200L4	M _{max}	Nm (lb in)		240 (2124)	318 (2815)	390 (3452)	478 (4231)	565 (5001)	600 (5310)
	n _{base}	rpm		1086	1025	966	893	823	796
DRE225S4	M _{max}	Nm (lb in)			317 (2806)	391 (3461)	481 (4257)	571 (5054)	600 (5310)
	n _{base}	rpm			1104	1060	1004	949	928
DRE225M4	M _{max}	Nm (lb in)				390 (3452)	482 (4266)	574 (5080)	600 (5310)
	n _{base}	rpm				1122	1081	1037	1092

Note:
The data is based on a line voltage of AC 400 V.

Assignment of MOVIDRIVE® MDX61B0900-503 ... MDX61B2500-503 (sizes 6 ... 7):

Motor voltage			MOVIDRIVE® MDX61B...-5_3 (AC 400/500 V units) in CFC operating modes (P700)					
AC 400 / 50 Hz			0900	1100	1320	1600	2000	2500
DRE315K4	M _{max}	Nm (lb in)	948 (8391)	1128 (9984)	1424 (12603)	1600 (14161)	1600 (14161)	1600 (14161)
	n _{base}	rpm	1068	1056	1030	1068	1216	1234
DRE315S4	M _{max}	Nm (lb in)		1158 (10249)	1477 (13073)	1600 (14161)	1600 (14161)	1600 (14161)
	n _{base}	rpm		1071	1053	1155	1373	1487
DRE315M4	M _{max}	Nm (lb in)			1441 (12754)	1745 (15445)	2227 (19711)	2400 (21242)
	n _{base}	rpm			1043	1028	1000	1096
DRE315L4	M _{max}	Nm (lb in)	Note:			1717 (15197)	2199 (19463)	2400 (21242)
	n _{base}	rpm	The data is based on a line voltage of AC 400 V.			1035	1018	1122



Motor Selection

Motor selection for asynchronous AC and servomotors (CFC)

AC 230/400 V / 50Hz motors in delta connection

Assignment of MOVIDRIVE® MDX61B0008-5A3 ... MDX61B0110-503 (sizes 0 ... 2):

Motor voltage			MOVIDRIVE® MDX61B...-5_3 (AC 400/500 V units) in CFC operating modes (P700)											
AC 230 / 50 Hz			0005	0008	0011	0014	0015	0022	0030	0040	0055	0075	0110	
DRE80M4	M _{max}	Nm (lb in)	9.4 (83)	12.1 (107)	14 (124)	12.1 (107)	14 (124)	14 (124)						
	n _{base}	rpm	1898	1787	1875	1804	1898	1957						
DRE90M4	M _{max}	Nm (lb in)				14 (124)	11.2 (99.1)	14 (124)	14 (124)					
	n _{base}	rpm				1980	1951	2015	2179					
DRE90L4	M _{max}	Nm (lb in)						16.2 (143)	21.5 (190)	28 (248)	28 (248)			
	n _{base}	rpm						1839	1757	1716	1834			
DRE100M4	M _{max}	Nm (lb in)							20.2 (179)	28.2 (250)	37.6 (333)	40 (354)		
	n _{base}	rpm							2074	1962	1828	1904		
DRE100LC4	M _{max}	Nm (lb in)								27.4 (243)	37.1 (328)	40 (354)	40 (354)	
	n _{base}	rpm								2033	1957	2185	2384	
DRE112M4	M _{max}	Nm (lb in)								28 (248)	37.6 (333)	40 (354)	40 (354)	
	n _{base}	rpm								1967	1870	2026	2070	
DRE132S4	M _{max}	Nm (lb in)									36.7 (325)	47.8 (423)	55 (487)	
	n _{base}	rpm									2002	1923	2109	
DRE132M4	M _{max}	Nm (lb in)	The data is based on a line voltage of AC 400 V.										48.7 (431)	74.4 (658)
	n _{base}	rpm												
DRE132MC4	M _{max}	Nm (lb in)											71.7 (635)	
	n _{base}	rpm											1958	
DRE160S4	M _{max}	Nm (lb in)											72.4 (641)	
	n _{base}	rpm											1955	

Assignment of MOVIDRIVE® MDX61B0150-503 ... MDX61B0750-503 (size 3 ... 5):

Motor voltage			MOVIDRIVE® MDX61B...-5_3 (AC 400/500 V units) in CFC operating modes (P700)						
AC 230 / 50 Hz			0150	0220	0300	0370	0450	0550	0750
DRE132M4	M _{max}	Nm (lb in)	99.8 (883)	110 (974)					
	n _{base}	rpm	1655	1591					
DRE132MC4	M _{max}	Nm (lb in)	97.8 (866)	110 (974)					
	n _{base}	rpm	1875	2073					
DRE160S4	M _{max}	Nm (lb in)	98.7 (874)	110 (974)	The data is based on a line voltage of AC 400 V.				
	n _{base}	rpm	1863	2065					
DRE160M4	M _{max}	Nm (lb in)	96.8 (857)	142 (1257)	188 (1664)	200 (1770)			
	n _{base}	rpm	1938	1814	1683	1700			
DRE160MC4	M _{max}	Nm (lb in)	93.3 (826)	137 (1213)	180 (1593)	200 (1770)	200 (1770)		
	n _{base}	rpm	2100	2003	1898	1938	1990		
DRE180S4	M _{max}	Nm (lb in)	99.1 (877)	147 (1301)	194 (1717)	200 (1770)			
	n _{base}	rpm	1922	1816	1696	1759			



Motor voltage			MOVIDRIVE® MDX61B...-5_3 (AC 400/500 V units) in CFC operating modes (P700)						
AC 230 / 50 Hz			0150	0220	0300	0370	0450	0550	0750
DRE180M4	M _{max}	Nm (lb in)		144 (1275)	191 (1690)	200 (1770)	200 (1770)		
	n _{base}	rpm		1925	1839	1995	2058		
DRE180L4	M _{max}	Nm (lb in)		143 (1266)	192 (1699)	236 (2088)	290 (2567)	344 (2956)	400 (3540)
	n _{base}	rpm		1889	1836	1779	1703	1623	1570
DRE180LC4	M _{max}	Nm (lb in)			185 (1637)	232 (2053)	289 (2558)	344 (2956)	400 (3540)
	n _{base}	rpm			1793	1749	1690	1623	1617
DRE200L4	M _{max}	Nm (lb in)					269 (2381)	320 (2832)	400 (3540)
	n _{base}	rpm					1895	1834	1728
DRE225S4	M _{max}	Nm (lb in)						319 (2823)	401 (3549)
	n _{base}	rpm						1957	1883
DRE225M4	M _{max}	Nm (lb in)							400 (3540)
	n _{base}	rpm							1980

Note:
The data is based on a line voltage of AC 400 V.

Assignment of MOVIDRIVE® MDX61B0900-503 ... MDX61B2500-503 (sizes 6 ... 7):

Motor voltage			MOVIDRIVE® MDX61B...-5_3 (AC 400/500 V units) in CFC operating modes (P700)					
AC 230 / 50 Hz			0900	1100	1320	1600	2000	2500
DRE180LC4	M _{max}	Nm (lb in)	400 (3540)					
	n _{base}	rpm	1670					
DRE200L4	M _{max}	Nm (lb in)	526 (4655)	600 (5310)				
	n _{base}	rpm	1561	1464				
DRE225S4	M _{max}	Nm (lb in)	530 (4691)	600 (5310)				
	n _{base}	rpm	1754	1708				
DRE225M4	M _{max}	Nm (lb in)	532 (4709)	600 (5310)	600 (5310)			
	n _{base}	rpm	1886	1883	1980			
DRE315K4	M _{max}	Nm (lb in)				963 (8523)	1238 (10957)	1543 (13657)
	n _{base}	rpm				1884	1851	1807
DRE315S4	M _{max}	Nm (lb in)					1277 (11302)	1600 (14161)
	n _{base}	rpm					1876	1856
DRE315M4	M _{max}	Nm (lb in)					1248 (11046)	1564 (13843)
	n _{base}	rpm					1848	1828
DRE315L4	M _{max}	Nm (lb in)						1536 (13595)
	n _{base}	rpm						1836

Note:
The data is based on a line voltage of AC 400 V.



Motor Selection

Motor selection for asynchronous AC and servomotors (CFC)

8.3.14 DRE motor selection in delta connection type (line AC 230 V / 50 Hz)

AC 230/400 V / 50 Hz motors in delta connection

Motor voltage			MOVIDRIVE® MDX61B...-2_3 (AC 230 V units) in CFC operating modes (P700)								
AC 230 V / 50 Hz			0015	0022	0037	0055	0075	0110	0150	0220	0300
DRE80M4	M _{max}	Nm	14								
		(lb in)	(120)								
	n _{base}	rpm	890								
DRE90M4	M _{max}	Nm	14								
		(lb in)	(120)								
	n _{base}	rpm	1084								
DRE90L4	M _{max}	Nm	22.5	27	28						
		(lb in)	(896)	(240)	(250)						
	n _{base}	rpm	896	832	867						
DRE100M4	M _{max}	Nm	21.2	25.3	40						
		(lb in)	(188)	(224)	(350)						
	n _{base}	rpm	1113	1072	925						
DRE100LC4	M _{max}	Nm		24.5	40	40					
		(lb in)		(217)	(350)	(350)					
	n _{base}	rpm		1136	1089	1212					
DRE112M4	M _{max}	Nm		25.1	40	40					
		(lb in)		(222)	(350)	(350)					
	n _{base}	rpm		1103	1040	1074					
DRE132S4	M _{max}	Nm			43.1	55					
		(lb in)			(381)	(490)					
	n _{base}	rpm			1079	1108					
DRE132M4	M _{max}	Nm			43.8	68	90.3	110			
		(lb in)			(388)	(600)	(799)	(974)			
	n _{base}	rpm			1108	1010	913	830			
DRE132MC4	M _{max}	Nm				65.1	88.1	110			
		(lb in)				(5576)	(780)	(974)			
	n _{base}	rpm				1103	1049	1084			
DRE160S4	M _{max}	Nm				65.8	88.9	110			
		(lb in)				(582)	(787)	(974)			
	n _{base}	rpm				1098	1041	1072			
DRE160M4	M _{max}	Nm					86.7	129	168	200	
		(lb in)					(767)	(1142)	(1487)	(1770)	
	n _{base}	rpm					1094	1015	940	900	
DRE160MC4	M _{max}	Nm					83.7	124	162	200	
		(lb in)					(741)	(1097)	(1434)	(1770)	
	n _{base}	rpm					1190	1129	1067	1072	
DRE180S4	M _{max}	Nm					88.6	133	174	200	
		(lb in)					(784)	(1177)	(1540)	(1770)	
	n _{base}	rpm					1089	1022	956	946	
DRE180M4	M _{max}	Nm						130	171	200	
		(lb in)						(1151)	(1513)	(1770)	
	n _{base}	rpm						1092	1042	1115	
DRE180L4	M _{max}	Nm							171	260	311
		(lb in)							(1513)	(2301)	(2753)
	n _{base}	rpm							1039	962	913
DRE180LC4	M _{max}	Nm								257	310
		(lb in)								(2275)	(2744)
	n _{base}	rpm								959	923
DRE200L4	M _{max}	Nm								240	288
		(lb in)								(2124)	(2549)
	n _{base}	rpm								1086	1048

Note:

The data is based on a line voltage of AC 230 V.



Motor voltage		MOVIDRIVE® MDX61B...-2_3 (AC 230 V units) in CFC operating modes (P700)								
AC 230 V / 50 Hz		0015	0022	0037	0055	0075	0110	0150	0220	0300
DRE225S4	M_{max}	Nm								285
		(lb in)								(2522)
	n_{base}	rpm								1122

8.3.15 Motor table DRP AC motors (characteristic value with delta/star connection AC 230/400 V)

Motor	P_m kW	M_N Nm (lb in)	Mass moment of inertia J_M without brake with brake 10^{-4} kgm^2		Star \star (AC 400 V)				Delta Δ (AC 230 V)			
			I_n A	$I_{q_n^{(1)}}$ A	$I_{d_n^{(1)}}$ A	$k_T^{(1)}$ Nm/A (lb in/A)	I_n A	$I_{q_n^{(1)}}$ A	$I_{d_n^{(1)}}$ A	k_T Nm/A (lb in/A)		
DRP90M4	0.75	5 (44)	35.5	40	1.81	1.38	1.17	3.58 (31.7)	3.14	2.39	2.02	2.07 (18.3)
DRP90L4	1.1	7.3 (65)	43.5	48.5	2.4	1.86	1.52	3.93 (34.8)	4.16	3.22	2.63	2.27 (20.1)
DRP100M4	1.5	9.9 (88)	56	62	3.2	2.82	1.51	3.51 (31.1)	5.54	4.88	2.62	2.03 (18.0)
DRP100L4	2.2	14.6 (129)	90	96	4.75	3.92	2.68	3.72 (32.9)	8.23	6.79	4.65	2.15 (19.0)
DRP112M4	3	19.7 (174)	146	151	6	5.53	2.34	3.57 (31.6)	10.4	9.6	4.1	2.06 (18.2)
DRP132M4	4	26 (230)	255	265	7.7	7.15	2.85	3.64 (32.2)	13.3	12.4	4.9	2.10 (18.6)
DRP132MC4	5.5	35.5 (314)	340	355	11	9.93	4.69	3.57 (31.6)	19	17.2	8.1	2.06 (18.2)
DRP160S4	5.5	35.5 (314)	370	390	10.9	9.39	5.53	3.78 (33.5)	19	16.3	9.6	2.18 (19.3)
DRP160M4	7.5	48.5 (429)	450	500	14.5	13.4	6.06	3.62 (32.0)	25	23.2	10.5	2.09 (18.5)
DRP160MC4	9.2	59 (522)	590	640	17.8	16.6	5.42	3.55 (31.4)	31	28.8	9.4	2.05 (18.1)
DRP180S4	9.2	60 (531)	895	955	18	15.2	8.63	3.94 (34.9)	31	26.4	15.0	2.28 (20.2)
DRP180M4	11	71 (628)	1110	1170	21	18.6	8.46	3.83 (33.9)	36	32.1	14.7	2.21 (19.6)
DRP180L4	15	97 (859)	1300	1440	28	24.4	12.8	3.97 (35.1)	48	42.3	22.2	2.29 (20.3)
DRP180LC4	18.5	119 (1053)	1790	1930	35	31.1	15.8	3.82 (33.8)	61	53.9	27.4	2.21 (19.6)
DRP200L4	22	142 (1257)	2360	2500	41	37.6	16.3	3.77 (33.4)	71	65.2	28.2	2.18 (19.3)
DRP225S4	30	193 (1708)	2930	3160	55	49.4	23.4	3.91 (34.6)	95	85.5	40.5	2.26 (20.0)
DRP225M4	37	240 (2124)	3430	3660	69	63.8	26.4	3.76 (33.3)	120	110	45.7	2.17 (19.2)
DRP315K4	90	580 (5133)	18400	19500	159	149	54.8	3.89 (34.4)	340	259	94.9	2.24 (19.8)
DRP315S4	110	710 (6284)	22500	23600	192	176	76.2	4.03 (35.7)	-	-	-	-
DRP315M4	132	850 (7523)	27900	29000	230	212	89.2	4.01 (35.5)	-	-	-	-
DRP315L4	160	1030 (9116)	31900	33000	275	252	110	4.09 (36.2)	-	-	-	-

1) Applies in the basic speed range up to n_{base} .



Motor Selection

Motor selection for asynchronous AC and servomotors (CFC)

8.3.16 DRP motor selection with delta/star connection type (line AC 400 V / 50 Hz)

AC 230/400 V / 50 Hz motors in star connection or AC 400/690 V / 50 Hz in delta connection

Assignment of MOVIDRIVE® MDX61B0005-5A3 ... MDX61B0110-503 (sizes 0 ... 2):

Motor voltage			MOVIDRIVE® MDX61B...-5_3 (AC 400/500 V units) in CFC operating modes (P700)										
AC 400 / 50 Hz			0005	0008	0011	0014	0015	0022	0030	0040	0055	0075	0110
DRP90M4	M_{max}	Nm (lb in)	13.7 (121)	14 (124)			14 (124)						
	n_{base}	rpm	890	943			955						
DRP90L4	M_{max}	Nm (lb in)	14 (124)	14 (124)	14 (124)		14 (124)						
	n_{base}	rpm	914	1037	1101		1101						
DRP100M4	M_{max}	Nm (lb in)			21.2 (188)	27.7 (245)	20.5 (181)	28 (248)	28 (248)				
	n_{base}	rpm			984	896	996	896	925				
DRP100L4	M_{max}	Nm (lb in)				28 (248)	20 (177)	29 (257)	37.8 (335)	40 (354)			
	n_{base}	rpm				1002	1066	990	919	972			
DRP112M4	M_{max}	Nm (lb in)						28.2 (250)	36.5 (323)	40 (354)			
	n_{base}	rpm						1088	1025	1079			
DRP132M4	M_{max}	Nm (lb in)							36.8 (326)	50.9 (451)	55 (487)		
	n_{base}	rpm							1186	1113	1196		
DRP132MC4	M_{max}	Nm (lb in)								48.2 (427)	65.1 (576)	84.4 (747)	110 (974)
	n_{base}	rpm								1044	1001	947	908
DRP160S4	M_{max}	Nm (lb in)								49.8 (441)	67.9 (601)	88.5 (783)	110 (974)
	n_{base}	rpm								1006	966	918	936
DRP160M4	M_{max}	Nm (lb in)									64.6 (572)	84.5 (748)	110 (974)
	n_{base}	rpm									1147	1103	1133
DRP160MC4	M_{max}	Nm (lb in)										83.7 (741)	127 (1124)
	n_{base}	rpm										1204	1111
DRP180S4	M_{max}	Nm (lb in)	Note: The data is based on a line voltage of AC 400 V.									87.6 (775)	136 (1204)
	n_{base}	rpm										1055	976
DRP180M4	M_{max}	Nm (lb in)										86.2 (763)	134 (1186)
	n_{base}	rpm										1082	1019
DRP180L4	M_{max}	Nm (lb in)											133 (1177)
	n_{base}	rpm											1026



Assignment of MOVIDRIVE® MDX61B0150-503 ... MDX61B0750-503 (size 3 ... 5):

Motor voltage			MOVIDRIVE® MDX61B...-5_3 (AC 400/500 V units) in CFC operating modes (P700)						
AC 400 / 50 Hz			0150	0220	0300	0370	0450	0550	0750
DRP160MC4	M _{max}	Nm (lb in)	170 (1505)	200 (1770)					
	n _{base}	rpm	1015	953					
DRP180S4	M _{max}	Nm (lb in)	184 (1629)	200 (1770)					
	n _{base}	rpm	893	889					
DRP180M4	M _{max}	Nm (lb in)	181 (1602)	200 (1770)					
	n _{base}	rpm	946	952					
DRP180L4	M _{max}	Nm (lb in)	183 (1620)	200 (1770)					
	n _{base}	rpm	979	1128					
DRP180LC4	M _{max}	Nm (lb in)	173 (1531)	257 (2275)	339 (3000)	400 (3540)			
	n _{base}	rpm	1062	999	926	886			
DRP200L4	M _{max}	Nm (lb in)	170 (1505)	252 (2230)	333 (2947)	400 (3540)			
	n _{base}	rpm	1092	1025	952	896			
DRP225S4	M _{max}	Nm (lb in)		254 (2248)	340 (3009)	419 (3708)	515 (4558)	600 (5310)	
	n _{base}	rpm		969	925	881	826	788	
DRP225M4	M _{max}	Nm (lb in)			321 (2841)	397 (3514)	489 (4328)	580 (5133)	600 (5310)
	n _{base}	rpm			1125	1086	1040	990	1010
DRP315K4	M _{max}	Nm (lb in)							726 (6426)
	n _{base}	rpm							1028

Note:
The data is based on a line voltage of AC 400 V.

Assignment of MOVIDRIVE® MDX61B0900-503 ... MDX61B2500-503 (sizes 6 ... 7):

Motor voltage			MOVIDRIVE® MDX61B...-5_3 (AC 400/500 V units) in CFC operating modes (P700)					
AC 400 / 50 Hz			0900	1100	1320	1600	2000	2500
DRP315K4	M _{max}	Nm (lb in)	966 (8550)	1144 (10125)	1439 (12736)	1600 (14161)	1600 (14161)	
	n _{base}	rpm	1008	990	957	987	1079	
DRP315S4	M _{max}	Nm (lb in)	976 (8638)	1164 (10302)	1472 (13028)	1600 (14161)	1600 (14161)	1600 (14161)
	n _{base}	rpm	982	972	952	1028	1188	1234
DRP315M4	M _{max}	Nm (lb in)		1144 (10125)	1455 (12878)	1762 (15595)	2249 (19905)	2400 (21242)
	n _{base}	rpm		1053	1041	1025	997	1102
DRP315L4	M _{max}	Nm (lb in)	Note: The data is based on a line voltage of AC 400 V.		1460 (12922)	1777 (15728)	2278 (20162)	2400 (21242)
	n _{base}	rpm			1035	1025	1005	1142



Motor Selection

Motor selection for asynchronous AC and servomotors (CFC)

AC 230/400 V / 50 Hz motors in delta connection

Assignment of MOVIDRIVE® MDX61B0005-5A3 ... MDX61B0110-503 (sizes 0 ... 2):

Motor voltage			MOVIDRIVE® MDX61B...-5_3 (AC 400/500 V units) in CFC operating modes (P700)									
AC 230 / 50 Hz			0011	0014	0015	0022	0030	0040	0055	0075	0110	
DRP90M4	M_{max}	Nm (lb in)	12 (106)	14 (124)	11.6 (103)	14 (124)	14 (124)					
	n_{base}	rpm	1769	1839	1781	1869	1945					
DRP90L4	M_{max}	Nm (lb in)		14 (124)	12.2 (108)	14 (124)	14 (124)					
	n_{base}	rpm		1951	1716	1992	2232					
DRP100M4	M_{max}	Nm (lb in)				15.9 (141)	20.6 (182)	28 (248)	28 (248)			
	n_{base}	rpm				1951	1869	1746	1863			
DRP100L4	M_{max}	Nm (lb in)					20.1 (178)	28.8 (255)	38.9 (344)	40 (354)		
	n_{base}	rpm					1945	1857	1752	1945		
DRP112M4	M_{max}	Nm (lb in)						28 (248)	37.5 (332)	40 (354)		
	n_{base}	rpm						1982	1884	2036		
DRP132M4	M_{max}	Nm (lb in)							37.9 (335)	49.2 (435)	55 (487)	
	n_{base}	rpm							2119	2036	2236	
DRP132MC4	M_{max}	Nm (lb in)								46.5 (412)	72.3 (640)	
	n_{base}	rpm								1879	1787	
DRP160S4	M_{max}	Nm (lb in)	The data is based on a line voltage of AC 400 V.								47.9 (424)	75.6 (669)
	n_{base}	rpm										
DRP160M4	M_{max}	Nm (lb in)									72 (637)	
	n_{base}	rpm									2025	
DRP160MC4	M_{max}	Nm (lb in)									71.5 (633)	
	n_{base}	rpm									2188	
DRP180S4	M_{max}	Nm (lb in)									73.6 (651)	
	n_{base}	rpm									1909	



Assignment of MOVIDRIVE® MDX61B0150-503 ... MDX61B0750-503 (size 3 ... 5):

Motor voltage			MOVIDRIVE® MDX61B...-5_3 (AC 400/500 V units) in CFC operating modes (P700)						
AC 230 / 50 Hz			0150	0220	0300	0370	0450	0550	0750
DRP132MC4	M _{max}	Nm (lb in)	97.5 (863)	110 (974)					
	n _{base}	rpm	1679	1743					
DRP160S4	M _{max}	Nm (lb in)	102 (903)	110 (974)					
	n _{base}	rpm	1634	1788					
DRP160M4	M _{max}	Nm (lb in)	98 (867)	110 (974)					
	n _{base}	rpm	1942	2157					
Note: The data is based on a line voltage of AC 400 V.									
DRP160MC4	M _{max}	Nm (lb in)	96.9 (858)	140 (1239)	184 (1629)	200 (1770)			
	n _{base}	rpm	2113	1973	1823	1779			
DRP180S4	M _{max}	Nm (lb in)	102 (903)	151 (1336)	199 (1761)	200 (1770)			
	n _{base}	rpm	1852	1733	1607	1656			
DRP180M4	M _{max}	Nm (lb in)	100 (885)	148 (1310)	195 (1726)	200 (1770)			
	n _{base}	rpm	1895	1796	1683	1779			
DRP180L4	M _{max}	Nm (lb in)		149 (1319)	199 (1761)	200 (1770)	200 (1770)		
	n _{base}	rpm		1806	1743	1982	2091		
DRP180LC4	M _{max}	Nm (lb in)		189 (1673)	233 (2062)	288 (2549)	342 (3027)	400 (3540)	
	n _{base}	rpm		1872	1819	1749	1680	1633	
DRP200L4	M _{max}	Nm (lb in)			185 (1637)	229 (2027)	282 (2496)	335 (2965)	400 (3540)
	n _{base}	rpm			1913	1860	1787	1713	1634
DRP225S4	M _{max}	Nm (lb in)				229 (2027)	286 (2531)	343 (3036)	429 (3797)
	n _{base}	rpm				1740	1699	1658	1585
DRP225M4	M _{max}	Nm (lb in)						324 (2868)	407 (3602)
	n _{base}	rpm						1986	1921



Motor Selection

Motor selection for asynchronous AC and servomotors (CFC)

Assignment of MOVIDRIVE® MDX61B0900-503 ... MDX61B2500-503 (sizes 6 ... 7):

Motor voltage			MOVIDRIVE® MDX61B...-5_3 (AC 400/500 V units) in CFC operating modes (P700)								
AC 230 / 50 Hz			0900	1100	1320	1600	2000	2500			
DRP225S4	M_{max}	Nm (lb in)	567 (5018)	600 (5310)	600 (5310)	Note: The data is based on a line voltage of AC 400 V.					
	n_{base}	rpm	1461	1456	1456						
DRP225M4	M_{max}	Nm (lb in)	539 (4771)	600 (5310)	600 (5310)				Note: The data is based on a line voltage of AC 400 V.		
	n_{base}	rpm	1813	1801	1819						
DRP315K4	M_{max}	Nm (lb in)			809 (7160)	981 (8683)	1253 (11089)	1558 (13789)			
	n_{base}	rpm			1800	1777	1736	1683			

8.3.17 DRP motor selection in delta connection type (line AC 230 V / 50 Hz)

AC 230/400 V / 50 Hz motors in delta connection

Assignment of MOVIDRIVE® MDX61B0015-2A3 ... MDX61B0300-203 (sizes 1 ... 3):

Motor voltage			MOVIDRIVE® MDX61B...-5_3 (AC 400/500 V units) in CFC operating modes (P700)								
AC 230 / 60 Hz			0015	0022	0037	0055	0075	0110	0150	0220	0300
DRP90M4	M_{max}	Nm (lb in)	14 (124)								
	n_{base}	rpm	953								
DRP90L4	M_{max}	Nm (lb in)	14 (124)								
	n_{base}	rpm	1101								
DRP100M4	M_{max}	Nm (lb in)	21.6 (191)	25.6 (227)	40 (354)	Note: The data is based on a line voltage of AC 230 V.					
	n_{base}	rpm	978	925	925						
DRP100L4	M_{max}	Nm (lb in)	21.2 (188)	25.7 (227)	40 (354)	40 (354)					
	n_{base}	rpm	1054	1019	949	972					
DRP112M4	M_{max}	Nm (lb in)		25.1 (222)	40 (354)	40 (354)					
	n_{base}	rpm		1113	1044	1079					
DRP132M4	M_{max}	Nm (lb in)			44.4 (393)	55 (487)	55 (487)				
	n_{base}	rpm			1147	1196	1206				
DRP132MC4	M_{max}	Nm (lb in)				65.9 (583)	88.1 (780)	110 (974)			
	n_{base}	rpm				1001	937	908			
DRP160S4	M_{max}	Nm (lb in)				68.8 (609)	92.5 (819)	110 (974)			
	n_{base}	rpm				966	909	936			
DRP160M4	M_{max}	Nm (lb in)				65.4 (579)	88.3 (782)	110 (974)	110 (974)		
	n_{base}	rpm				1147	1094	1138	1177		
DRP160MC4	M_{max}	Nm (lb in)					87.4 (774)	128 (1133)	165 (1460)	200 (1770)	
	n_{base}	rpm					1195	1111	1028	953	
DRP180S4	M_{max}	Nm (lb in)					91.9 (813)	137 (1213)	179 (1584)	200 (1770)	
	n_{base}	rpm					1049	976	903	889	
DRP180M4	M_{max}	Nm (lb in)					90.3 (799)	135 (1195)	175 (1549)	200 (1770)	
	n_{base}	rpm					1079	1016	956	952	



Motor voltage			MOVIDRIVE® MDX61B...-5_3 (AC 400/500 V units) in CFC operating modes (P700)								
AC 230 / 60 Hz			0015	0022	0037	0055	0075	0110	0150	0220	0300
DRP180L4	M _{max}	Nm (lb in)						134 (1186)	177 (1567)	200 (1770)	
	n _{base}	rpm						1026	986	1128	
DRP180LC4	M _{max}	Nm (lb in)							168 (1487)	257 (2275)	308 (2726)
	n _{base}	rpm							1065	999	956
DRP200L4	M _{max}	Nm (lb in)							164 (1452)	252 (2230)	302 (2673)
	n _{base}	rpm							1095	1025	981
DRP225S4	M _{max}	Nm (lb in)	Note: The data is based on a line voltage of AC 230 V.							254 (2248)	307 (2717)
	n _{base}	rpm								969	943
DRP225M4	M _{max}	Nm (lb in)									290 (2567)
	n _{base}	rpm									1139



Motor Selection

Motor selection for asynchronous AC and servomotors (CFC)

8.3.18 Motor table DV series AC motors (characteristic value with delta/star connection AC 230/400 V / 50 Hz)

Motor	P _m kW	M _N Nm (lb in)	Mass moment of inertia J _M without brake with brake 10 ⁻⁴ kgm ²		Star \star (AC 400 V)				Delta Δ (AC 230 V)			
			I _n A	I _{q_n} ¹⁾ A	I _{d_n} ¹⁾ A	k _T ¹⁾ Nm/A (lb in/A)	I _n A	I _{q_n} ¹⁾ A	I _{d_n} ¹⁾ A	k _T Nm/A (lb in/A)		
DV250M4	55	356 (3151)	6300	6600/6730 ²⁾	102	91.7	44.7	3.88 (34.3)	177	159	77.4	2.24 (19.8)
DV280S4	75	484 (4284)	8925	9225/9355 ²⁾	138	120.4	67.5	4.02 (35.6)	239	209	117	2.32 (20.5)
DV280M4	90	581 (5142)	8925	9225/9355 ²⁾	170	149	81.9	3.9 (34.5)	295	258	142	2.25 (19.9)

1) Applies in the basic speed range up to n_{base}.

2) Double disk brake

8.3.19 DV motor selection with delta/star connection type (line 400 V / 50 Hz)

AC 230/400 V / 50 Hz motors in star connection or AC 400/690 V / 50 Hz motors in delta connection

Motor voltage AC 400 V / 50 Hz		MOVIDRIVE® MDX61B...-5_3 (AC 400/500 V units) in CFC operating modes (P700)									
		0150	0220	0300	0370	0450	0550	0750	0900	1100	1320
DV250M4	M _{max} Nm (lb in)						586.5 (5191)	641 (5670)	641 (5670)		
	n _{base} rpm						1018	1133	1357		
DV280S4	M _{max} Nm (lb in)							735.4 (6509)	871 (7710)	871 (7710)	
	n _{base} rpm							1082	1184	1344	
DV280M4	M _{max} Nm (lb in)								941 (8330)	1000 (8851)	1000 (8851)
	n _{base} rpm								1139	1254	1478

Note: The maximum torque M_{max} is limited to 180 % of the rated motor torque M_N. The data is based on a line voltage of AC 400 V.

AC 230/400 V / 50 Hz motors in delta connection

Motor voltage AC 230 V / 50 Hz		MOVIDRIVE® MDX61B...-5_3 (AC 400/500 V units) in CFC operating modes (P700)									
		0150	0220	0300	0370	0450	0550	0750	0900	1100	1320
DV250M4	M _{max} Nm (lb in)								542 (4800)	641 (5670)	641 (5670)
	n _{base} rpm								1843	1837	2227
DV280S4	M _{max} Nm (lb in)									638.2 (5649)	823.2 (7286)
	n _{base} rpm									1946	1920

Note: The maximum torque M_{max} is limited to 180 % of the rated motor torque M_N. The data is based on a line voltage of AC 400 V.



8.3.20 Motor table DRS series AC motors (characteristic value with double-star/star connection AC 230/460 V / 60 Hz)

Motor	P _m kW	M _N Nm (lb in)	Mass moment of inertia J _M without brake with brake 10 ⁻⁴ kgm ²		Star Δ (AC 460 V)				Double-star Y (AC 230 V)			
			I _n A	I _{q_n} ¹⁾ A	I _{d_n} ¹⁾ A	k _T ¹⁾ Nm/A (lb in/A)	I _n A	I _{q_n} ¹⁾ A	I _{d_n} ¹⁾ A	k _T ¹⁾ Nm/A (lb in/A)		
DRS71S4	0.37	2.1 (18.6)	4.9	6.2	0.92	0.92	0.58	2.93 (25.9)	1.84	1.43	1.16	1.47 (13.0)
DRS71M4	0.55	3.1 (27.4)	7.1	8.4	1.25	1.25	0.75	3.09 (27.3)	2.50	2.00	1.49	1.55 (13.7)
DRS80S4	0.75	4.2 (37.2)	14.9	16.4	1.66	1.66	1.12	3.43 (30.4)	3.32	2.45	2.24	1.71 (15.1)
DRS80M4	1.1	6.1 (54.0)	21.5	26	2.14	2.14	1.23	3.48 (30.8)	4.28	3.50	2.46	1.74 (15.4)
DRS90M4	1.5	8.4 (74.3)	35.5	40	2.87	2.87	1.38	3.34 (29.6)	5.74	5.03	2.76	1.67 (14.8)
DRS90L4	2.2	12.2 (108)	43.5	49.5	4.1	4.1	2.37	3.66 (32.4)	8.20	6.66	4.75	1.83 (16.2)
DRS100M4	3	16.7 (148)	56	62	5.5	5.5	2.45	3.39 (30.0)	11.0	9.85	4.90	1.70 (15.0)
DRS100M4	3.7	21 (186)	56	62	6.65	6.65	2.42	3.39 (30.0)	13.3	12.4	4.84	1.70 (15.0)
DRS100L4	4	22.5 (199)	68.3	74.3	7.3	7.3	3.78	3.60 (31.9)	14.6	12.5	7.56	1.80 (15.9)
DRS112M4	4	22 (195)	146	151	6.8	6.8	2.26	3.43 (30.4)	13.6	12.8	4.52	1.71 (15.1)
DRS132S4	5.5	30 (266)	190	200	9.4	9.4	3.36	3.42 (30.3)	18.8	17.6	6.72	1.71 (15.1)
DRS132M4	7.5	41 (363)	255	265	12.4	12.4	4.01	3.50 (31.0)	24.8	23.5	8.02	1.75 (15.5)
DRS132MC4	9.2	50 (443)	342	355	16	16	6.33	3.40 (30.1)	32.0	29.4	12.7	1.70 (15.0)
DRS160S4	9.2	50 (443)	370	420	15.9	15.9	7.2	3.53 (31.2)	31.8	28.4	14.4	1.76 (15.6)
DRS160M4	11	60 (531)	450	500	18.8	18.8	6.99	3.44 (30.4)	37.6	34.9	14.0	1.72 (15.2)
DRS160MC4	15	81 (717)	590	640	26.5	26.5	9.57	3.28 (29.0)	53.0	49.4	19.1	1.64 (14.5)
DRS180S4	15	81 (717)	895	955	25.5	25.5	9.68	3.43 (30.4)	51.0	47.2	19.4	1.72 (15.2)
DRS180M4	18.5	100 (885)	1110	1250	30.5	30.5	14.1	3.70 (32.7)	61.0	54.1	28.2	1.85 (16.4)
DRS180L4	22	119 (1053)	1300	1440	35.9	35.9	16.0	3.70 (32.7)	71.8	64.2	32.0	1.85 (16.4)
DRS180LC4	30	161 (1425)	1680	1910	48.5	48.5	16.9	3.54 (31.3)	97.0	90.9	33.8	1.77 (15.7)
DRS200L4	30	161 (1425)	2360	2590	51	51	17.6	3.36 (29.7)	102	95.8	35.1	1.68 (14.9)
DRS225S4	37	198 (1752)	2930	3160	61	61	22.6	3.50 (31.0)	122	113	45.3	1.75 (15.5)
DRS225M4	45	240 (2124)	3430	3660	72	72	21.7	3.50 (31.0)	144	137	43.4	1.75 (15.5)



Motor Selection

Motor selection for asynchronous AC and servomotors (CFC)

Motor	P _m kW	M _N Nm (lb in)	Mass moment of inertia J _M 10 ⁻⁴ kgm ²		Star \triangle (AC 460 V)				Double-star $\triangle\triangle$ (AC 230 V)			
			without brake	with brake	I _n A	I _{q_n} ¹⁾ A	I _{d_n} ¹⁾ A	k _T ¹⁾ Nm/A (lb in/A)	I _n A	I _{q_n} ¹⁾ A	I _{d_n} ¹⁾ A	k _T ¹⁾ Nm/A (lb in/A)
DRS225MC4	55	295 (2611)	4330	4560	87.9	87.9	24.2	3.49 (30.9)	176	169	48.4	1.75 (15.5)
DRS315K4	110	589 (5213)	18400	19500	172	172	47.4	3.56 (31.5)	-	-	-	-
DRS315S4	132	707 (6257)	22500	23600	205	205	43.4	3.49 (30.9)	-	-	-	-
DRS315S4	150	802 (7098)	22500	23600	230	230	60.7	3.62 (32.0)	-	-	-	-
DRS315M4	160	856 (7576)	27900	29000	245	245	60.3	3.60 (31.9)	-	-	-	-
DRS315M4	185	991 (8771)	27900	29000	280	280	59.9	3.62 (32.0)	-	-	-	-
DRS315L4	200	1072 (9488)	31900	33000	304	304	73.4	3.63 (32.1)	-	-	-	-
DRS315L4	225	1205 (10665)	31900	33000	335	335	72.8	3.67 (32.5)	-	-	-	-

1) Applies in the basic speed range up to n_{base}.



8.3.21 DRS motor selection with double-star/star connection type (line AC 460 / 60 Hz)

AC 230/460 V / 60 Hz motors in star connection

Assignment of MOVIDRIVE® MDX61B0005-5A3 ... MDX61B0110-503 (sizes 0 ... 2):

Motor voltage			MOVIDRIVE® MDX61B...-5_3 (AC 400/500 V units) in CFC operating modes (P700)										
AC 460 / 60 Hz			0005	0008	0011	0014	0015	0022	0030	0040	0055	0075	0110
DRS71S4	M _{max}	Nm (lb in)	10 (89)				10 (89)						
	n _{base}	rpm	439				439						
DRS71M4	M _{max}	Nm (lb in)	10 (89)				10 (89)						
	n _{base}	rpm	820				820						
DRS80S4	M _{max}	Nm (lb in)	13 (114)	14 (124)			14 (124)						
	n _{base}	rpm	978	955			960						
DRS80M4	M _{max}	Nm (lb in)	13.2 (117)	14 (124)	14 (124)		14 (124)						
	n _{base}	rpm	1130	1195	1259		1259						
DRS90M4	M _{max}	Nm (lb in)		15.3 (135)	20.1 (178)	26.2 (232)	19.4 (172)	27.1 (240)	28 (248)				
	n _{base}	rpm		1136	1025	878	1037	855	837				
DRS90L4	M _{max}	Nm (lb in)				28.1 (249)	20.3 (180)	29.1 (258)	37.6 (333)	40 (354)			
	n _{base}	rpm				1025	1130	1013	896	873			
DRS100M4 3 kW	M _{max}	Nm (lb in)						26.6 (235)	34.5 (305)	40 (354)			
	n _{base}	rpm						1241	1158	1171			
DRS100M4 3.7 kW	M _{max}	Nm (lb in)						26.5 (234)	23.4 (207)	40 (354)			
	n _{base}	rpm						1394	1318	1353			
DRS100L4	M _{max}	Nm (lb in)							34.9 (309)	40 (354)	40 (354)		
	n _{base}	rpm							1171	1289	1377		
DRS112M4	M _{max}	Nm (lb in)						27.1 (240)	35 (310)	48 (425)	55 (486)		
	n _{base}	rpm						1406	1342	1220	1181		
DRS132S4	M _{max}	Nm (lb in)								47.3 (419)	63.1 (558)	81.2 (719)	110 (974)
	n _{base}	rpm								1280	1190	1081	915
DRS132M4	M _{max}	Nm (lb in)								47.7 (422)	63.9 (566)	82.5 (730)	110 (974)
	n _{base}	rpm								1395	1331	1248	1139
DRS132MC4	M _{max}	Nm (lb in)									59.8 (529)	78.4 (694)	120 (1062)
	n _{base}	rpm									1401	1350	1228
DRS160S4	M _{max}	Nm (lb in)									60.8 (538)	80.4 (712)	123 (1089)
	n _{base}	rpm									1212	1173	1076
DRS160M4	M _{max}	Nm (lb in)										78.5 (695)	120 (1062)
	n _{base}	rpm										1357	1256
DRS160MC4	M _{max}	Nm (lb in)											113 (1000)
	n _{base}	rpm											1410

Note:

The data is based on a line voltage of AC 460 V.



Motor Selection

Motor selection for asynchronous AC and servomotors (CFC)

Motor voltage			MOVIDRIVE® MDX61B...-5_3 (AC 400/500 V units) in CFC operating modes (P700)										
AC 460 / 60 Hz			0005	0008	0011	0014	0015	0022	0030	0040	0055	0075	0110
DRS180S4	M_{max}	Nm (lb in)											119 (1053)
	n_{base}	rpm											1261
DRS180M4	M_{max}	Nm (lb in)	Note: The data is based on a line voltage of AC 460 V.										121 (1071)
	n_{base}	rpm											1231

Assignment of MOVIDRIVE® MDX61B0150-503 ... MDX61B0750-503 (size 3 ... 5):

Motor voltage			MOVIDRIVE® MDX61B...-5_3 (AC 400/500 V units) in CFC operating modes (P700)							
AC 460 / 60 Hz			0150	0220	0300	0370	0450	0550	0750	
DRS132MC4	M_{max}	Nm (lb in)	161 (1424)	200 (1770)						
	n_{base}	rpm	1100	985						
DRS160S4	M_{max}	Nm (lb in)	166 (1469)	200 (1770)						
	n_{base}	rpm	971	892						
DRS160M4	M_{max}	Nm (lb in)	162 (1434)	200 (1770)						
	n_{base}	rpm	1147	1054						
DRS160MC4	M_{max}	Nm (lb in)	154 (1363)	200 (1770)						
	n_{base}	rpm	1340	1331						
DRS180S4	M_{max}	Nm (lb in)	162 (1434)	200 (1770)						
	n_{base}	rpm	1182	1145						
DRS180M4	M_{max}	Nm (lb in)	168 (1487)	248 (2195)	327 (2894)	399 (3531)	400 (3540)			
	n_{base}	rpm	1185	1092	997	906	903			
DRS180L4	M_{max}	Nm (lb in)	167 (1478)	248 (2195)	327 (2894)	400 (3540)				
	n_{base}	rpm	1255	1185	1105	1029				
DRS180LC4	M_{max}	Nm (lb in)		238 (2106)	314 (2779)	385 (3407)	471 (4169)	557 (4930)	600 (5310)	
	n_{base}	rpm		1268	1198	1125	1039	952	909	
DRS200L4	M_{max}	Nm (lb in)		224 (1983)	297 (2629)	364 (3222)	445 (3939)	526 (4655)	600 (5310)	
	n_{base}	rpm		1303	1227	1151	1097	966	890	
DRS225S4	M_{max}	Nm (lb in)		228 (2018)	305 (2699)	375 (3319)	461 (4080)	546 (4833)	600 (5310)	
	n_{base}	rpm		1377	1321	1262	1189	1116	1069	
DRS225M4	M_{max}	Nm (lb in)			308 (2726)	378 (3346)	464 (4107)	550 (4868)	600 (5310)	
	n_{base}	rpm			1315	1265	1201	1133	1095	
DRS225MC4	M_{max}	Nm (lb in)				374 (3310)	460 (4071)	547 (4841)	680 (6019)	
	n_{base}	rpm				1356	1303	1248	1157	
DRS315K4	M_{max}	Nm (lb in)							673 (5957)	
	n_{base}	rpm							1423	



Assignment of MOVIDRIVE® MDX61B0900-503 ... MDX61B2500-503 (sizes 6 ... 7):

Motor voltage			MOVIDRIVE® MDX61B...-5_3 (AC 400/500 V units) in CFC operating modes (P700)					
AC 460 / 60 Hz			0900	1100	1320	1600	2000	2500
DRS225MC4	M _{max}	Nm (lb in)	892 (7895)	1051 (9302)	1200 (10621)			
	n _{base}	rpm	1019	922	840			
DRS315K4	M _{max}	Nm (lb in)	892 (7895)	1054 (9328)	1324 (11718)	1592 (14090)	1600 (14161)	
	n _{base}	rpm	1364	1318	1237	1154	1152	
DRS315S4 132 kW	M _{max}	Nm (lb in)	876 (7753)	1036 (9169)	1299 (11497)	1563 (13833)	1600 (14161)	
	n _{base}	rpm	1401	1359	1286	1210	1213	
DRS315S4 150 kW	M _{max}	Nm (lb in)	895 (7921)	1062 (9399)	1337 (11833)	1600 (14161)	1600 (14161)	
	n _{base}	rpm	1433	1403	1352	1301	1396	
DRS315M4 160 kW	M _{max}	Nm (lb in)		1059 (9373)	1334 (11806)	1607 (14223)	2043 (18082)	2400 (21242)
	n _{base}	rpm		1428	1381	1333	1247	1186
DRS315M4 185 kW	M _{max}	Nm (lb in)			1339 (11851)	1613 (14276)	2051 (18153)	2400 (21242)
	n _{base}	rpm			1394	1347	1264	1203
DRS315L4 200 kW	M _{max}	Nm (lb in)			1336 (21242)	1613 (14276)	2054 (18179)	2400 (21242)
	n _{base}	rpm			1438	1406	1347	1335
DRS315L4 225 kW	M _{max}	Nm (lb in)			1351 (11957)	1631 (14436)	2076 (18374)	2400 (21242)
	n _{base}	rpm			1447	1416	1357	1357

Note:
The data is based on a line voltage of AC 460 V.



Motor Selection

Motor selection for asynchronous AC and servomotors (CFC)

AC 230/460 V / 60 Hz motors in double-star connection

Assignment of MOVIDRIVE® MDX61B0005-5A3 ... MDX61B0110-503 (sizes 0 ... 2):

Motor voltage			MOVIDRIVE® MDX61B...-5_3 (AC 400/500 V units) in CFC operating modes (P700)										
AC 230 V / 60 Hz			0005	0008	0011	0014	0015	0022	0030	0040	0055	0075	0110
DRS71S4	M _{max}	Nm (lb in)	5.6 (49.6)	6.8 (60.2)	8.8 (77.9)	10 (89)	8.5 (75.2)	10 (89)					
	n _{base}	rpm	2343	2138	1804	1617	1851	1617					
DRS71M4	M _{max}	Nm (lb in)		7.1 (63)	9.3 (82.3)	10 (89)	9 (79.7)	10 (89)					
	n _{base}	rpm		2443	2197	2144	2233	2144					
DRS80S4	M _{max}	Nm (lb in)			9.8 (86.7)	13 (115)	9.4 (83)	13.4 (119)	14 (124)				
	n _{base}	rpm			2554	2384	2572	2361	2548				
DRS80M4	M _{max}	Nm (lb in)				13.2 (117)	9.5 (84.1)	13.7 (121)	14 (124)	14 (124)			
	n _{base}	rpm				2560	2689	2543	2941	3117			
DRS90M4	M _{max}	Nm (lb in)						12.9 (114)	16.9 (150)	23.3 (206)	28 (248)		
	n _{base}	rpm						2601	2472	2255	2103		
DRS90L4	M _{max}	Nm (lb in)							17.2 (152)	24.7 (219)	33.4 (296)	40 (354)	40 (354)
	n _{base}	rpm							2525	2396	2238	2185	2244
DRS100M4 3 kW	M _{max}	Nm (lb in)								22.6 (200)	30.6 (271)	39.7 (351)	40 (354)
	n _{base}	rpm								2718	2607	2472	2777
DRS100M4 3.7 kW	M _{max}	Nm (lb in)									30.5 (270)	39.6 (350)	40 (354)
	n _{base}	rpm									2923	2789	3210
DRS100L4	M _{max}	Nm (lb in)									30.6 (271)	40 (354)	40 (354)
	n _{base}	rpm									2566	2513	3193
DRS112M4	M _{max}	Nm (lb in)									31.1 (275)	40.2 (356)	55 (487)
	n _{base}	rpm									2880	2749	2592
DRS132S4	M _{max}	Nm (lb in)										39.4 (349)	60.5 (535)
	n _{base}	rpm										2749	2563
DRS132M4	M _{max}	Nm (lb in)											61.2 (542)
	n _{base}	rpm											2797

Note:

The data is based on a line voltage of AC 460 V.

Assignment of MOVIDRIVE® MDX61B0150-503 ... MDX61B0750-503 (size 3 ... 5):

Motor voltage			MOVIDRIVE® MDX61B...-5_3 (AC 400/500 V units) in CFC operating modes (P700)						
AC 230 V / 60 Hz			0150	0220	0300	0370	0450	0550	0750
DRS132S4	M _{max}	Nm (lb in)	81.2 (719)	110 (974)					
	n _{base}	rpm	2358	2075					
DRS132M4	M _{max}	Nm (lb in)	82.5 (730)	110 (974)					
	n _{base}	rpm	2646	2485					
DRS132MC4	M _{max}	Nm (lb in)	78.4 (694)	114 (1009)	150 (1327)	184 (1629)	200 (1770)		
	n _{base}	rpm	2807	2636	2446	2270	2187		
DRS160S4	M _{max}	Nm (lb in)	80.4 (712)	118 (1044)	156 (1381)	190 (1682)	200 (1770)		
	n _{base}	rpm	2443	2311	2162	2025	2017		

Note:

The data is based on a line voltage of AC 460 V.



Motor voltage			MOVIDRIVE® MDX61B...-5_3 (AC 400/500 V units) in CFC operating modes (P700)							
AC 230 V / 60 Hz			0150	0220	0300	0370	0450	0550	0750	
DRS160M4	M _{max}	Nm (lb in)	78.5 (695)	115 (1018)	152 (1345)	185 (1637)	200 (1770)			
	n _{base}	rpm	2799	2654	2496	2346	2293			
DRS160MC4	M _{max}	Nm (lb in)		108 (956)	144 (1275)	176 (1558)	200 (1770)	200 (1770)		
	n _{base}	rpm		2913	2821	2724	2772	2948		
DRS180S4	M _{max}	Nm (lb in)		114 (1009)	151 (1336)	185 (1637)	200 (1770)			
	n _{base}	rpm		2629	2516	2400	2453			
DRS180M4	M _{max}	Nm (lb in)			157 (1390)	194 (1717)	240 (2124)	285 (2522)	355 (3142)	
	n _{base}	rpm			2463	2393	2304	2211	2058	
DRS180L4	M _{max}	Nm (lb in)			155 (1372)	193 (1708)	239 (2115)	284 (2514)	355 (3142)	
	n _{base}	rpm			2589	2540	2470	2397	2274	
DRS180LC4	M _{max}	Nm (lb in)				185 (1637)	229 (2027)	273 (2416)	341 (3018)	
	n _{base}	rpm				2686	2623	2553	2433	
DRS200L4	M _{max}	Nm (lb in)					217 (1921)	258 (2283)	323 (2859)	
	n _{base}	rpm					2680	2601	2472	
DRS225S4	M _{max}	Nm (lb in)						263 (2328)	331 (2930)	
	n _{base}	rpm						2751	2654	
DRS225M4	M _{max}	Nm (lb in)	Note: The data is based on a line voltage of AC 460 V.							335 (2965)
	n _{base}	rpm								2645
DRS225MC4	M _{max}	Nm (lb in)							330 (2921)	
	n _{base}	rpm							2800	



Motor Selection

Motor selection for asynchronous AC and servomotors (CFC)

Assignment of MOVIDRIVE® MDX61B0900-503 ... MDX61B2500-503 (sizes 6 ... 7):

Motor voltage			MOVIDRIVE® MDX61B...-5_3 (AC 400/500 V units) in CFC operating modes (P700)					
AC 230 V / 60 Hz			0900	1100	1320	1600	2000	2500
DRS180LC4	M _{max}	Nm (lb in)	450 (3983)	530 (4691)	600 (5310)			
	n _{base}	rpm	2237	2088	1965			
DRS200L4	M _{max}	Nm (lb in)	425 (3761)	501 (4434)	600 (5310)			
	n _{base}	rpm	2255	2094	1901			
DRS225S4	M _{max}	Nm (lb in)	439 (3885)	519 (4594)	600 (5310)			
	n _{base}	rpm	2490	2361	2229			
DRS225M4	M _{max}	Nm (lb in)	443 (3921)	523 (4629)	600 (5310)			
	n _{base}	rpm	2502	2387	2279			
DRS225MC4	M _{max}	Nm (lb in)	439 (3885)	520 (4602)	654 (5788)	786 (6957)	998 (8833)	1200 (10621)
	n _{base}	rpm	2683	2586	2419	2252	2001	1787

Note:
The data is based on a line voltage of AC 460 V.

8.3.22 DRS motor selection in double-star connection (line AC 230 V / 60 Hz)

AC 230/460 V / 60 Hz motors in double-star connection

Assignment of MOVIDRIVE® MDX61B0015-2A3 ... MDX61B0300-203 (sizes 1 ... 4):

Motor voltage			MOVIDRIVE® MDX61B...-5_3 (AC 230 V units) in CFC operating modes (P700)								
AC 230 V / 60 Hz			0015	0022	0037	0055	0075	0110	0150	0220	0300
DRS71S4	M _{max}	Nm (lb in)	10 (89)								
	n _{base}	rpm	439								
DRS71M4	M _{max}	Nm (lb in)	10 (89)								
	n _{base}	rpm	820								
DRS80S4	M _{max}	Nm (lb in)	14 (124)								
	n _{base}	rpm	960								
DRS80M4	M _{max}	Nm (lb in)	14 (124)								
	n _{base}	rpm	1248								
DRS90M4	M _{max}	Nm (lb in)	17.6 (156)	21 (186)	28 (248)						
	n _{base}	rpm	1084	1002	837						
DRS90L4	M _{max}	Nm (lb in)	18.1 (160)	22.1 (196)	39 (345)	40 (354)					
	n _{base}	rpm	1160	1107	878	873					
DRS100M4 3 kW	M _{max}	Nm (lb in)		20.2 (179)	35.8 (317)	40 (354)					
	n _{base}	rpm		1300	1148	1177					
DRS100M4 3.7 kW	M _{max}	Nm (lb in)			35.7 (316)	40 (354)					
	n _{base}	rpm			1300	1371					
DRS100L4	M _{max}	Nm (lb in)			36.4 (322)	40 (354)					
	n _{base}	rpm			1166	1359					
DRS112M4	M _{max}	Nm (lb in)			36.3 (320)	55 (487)					
	n _{base}	rpm			1328	1162					

Note:
The data is based on a line voltage of AC 230 V.



Motor voltage			MOVIDRIVE® MDX61B...-5_3 (AC 230 V units) in CFC operating modes (P700)									
AC 230 V / 60 Hz			0015	0022	0037	0055	0075	0110	0150	0220	0300	
DRS132S4	M _{max}	Nm (lb in)			35.4 (313)	55.2 (489)	73.5 (651)	107 (947)	110 (974)			
	n _{base}	rpm			1342	1235	1127	932	918			
DRS132M4	M _{max}	Nm (lb in)				55.8 (494)	74.6 (660)	109 (965)	110 (974)			
	n _{base}	rpm				1362	1284	1132	1142			
DRS132MC4	M _{max}	Nm (lb in)					70.5 (624)	104 (920)	135 (1195)	200 (1770)		
	n _{base}	rpm					1372	1279	1181	986		
DRS160S4	M _{max}	Nm (lb in)					72.1 (638)	107 (947)	139 (1230)	200 (1770)		
	n _{base}	rpm					1190	1111	1037	892		
DRS160M4	M _{max}	Nm (lb in)					70.4 (623)	105 (929)	136 (1204)	200 (1770)		
	n _{base}	rpm					1375	1296	1217	1054		
DRS160MC4	M _{max}	Nm (lb in)						98.3 (870)	128 (1133)	194 (1717)	200 (1770)	
	n _{base}	rpm						1432	1384	1270	1344	
DRS180S4	M _{max}	Nm (lb in)						103 (912)	135 (1195)	200 (1770)	200 (1770)	
	n _{base}	rpm						1291	1235	1118	1145	
DRS180M4	M _{max}	Nm (lb in)							139 (1230)	214 (1894)	257 (2275)	
	n _{base}	rpm							1215	1132	1082	
DRS180L4	M _{max}	Nm (lb in)								213 (1885)	256 (2266)	
	n _{base}	rpm								1215	1175	
DRS180LC4	M _{max}	Nm (lb in)	Note: The data is based on a line voltage of AC 230 V.								205 (1814)	246 (2177)
	n _{base}	rpm									1298	1261
DRS200L4	M _{max}	Nm (lb in)								193 (1708)	232 (2053)	
	n _{base}	rpm								1335	1297	
DRS225S4	M _{max}	Nm (lb in)									236 (2088)	
	n _{base}	rpm									1371	



Motor Selection

Motor selection for asynchronous AC and servomotors (CFC)

8.3.23 Motor table DRE series AC motors (characteristic value with double-star/star connection AC 230/460 V / 60 Hz)

Motor	P _m kW	M _N Nm (lb in)	Mass moment of inertia J _M 10 ⁻⁴ kgm ²		Star Δ (AC 460 V)				Double-star Y (AC 230 V)			
			without brake	with brake	I _n A	I _{q_n} ¹⁾ A	I _{d_n} ¹⁾ A	k _T ¹⁾ Nm/A (lb in/A)	I _n A	I _{q_n} ¹⁾ A	I _{d_n} ¹⁾ A	k _T ¹⁾ Nm/A (lb in/A)
DRE80M4	0.75	4.1 (36.3)	21.5	23	1.44	1.15	0.86	3.56 (31.5)	2.88	2.31	1.73	1.78 (15.8)
DRE90M4	1.1	6 (53.1)	35.5	40	2.30	1.83	1.39	3.27 (28.9)	4.60	3.67	2.77	1.63 (14.4)
DRE90L4	1.5	8.2 (72.6)	43.5	48.5	2.80	2.14	1.80	3.83 (33.9)	5.60	4.28	3.61	1.91 (16.9)
DRE100L4	2.2	12.1 (107)	68	74	4.00	3.39	2.12	3.57 (31.6)	8.0	6.8	4.25	1.78 (15.8)
DRE100LC4	3	16.3 (144)	89.8	95.8	5.40	5.14	2.58	3.17 (28.1)	10.8	10.3	5.16	1.59 (14.1)
DRE100LC4	3.7	20 (177)	89.8	95.8	6.40	5.85	2.60	3.42 (30.3)	12.8	11.7	5.20	1.71 (15.1)
DRE112M4	3.7	20 (177)	146	151	6.30	5.96	2.04	3.35 (29.7)	12.6	11.9	4.07	1.68 (14.9)
DRE132S4	4	21.6 (191)	190	195	7.90	6.36	2.79	3.39 (30)	15.8	12.7	5.59	1.70 (15.0)
DRE132M4	5.5	30 (266)	255	265	9.00	8.57	2.74	3.50 (31.0)	18.0	17.1	5.49	1.75 (15.5)
DRE132MC4	7.5	40.5 (359)	340	355	12.9	11.5	5.93	3.54 (31.3)	25.8	22.9	11.9	1.77 (15.7)
DRE160S4	7.5	40.5 (358)	370	390	12.7	11.4	5.66	3.56 (31.5)	25.4	22.7	11.3	1.78 (15.8)
DRE160M4	9.2	49.5 (438)	450	500	15.4	14.0	6.52	3.55 (31.4)	30.8	27.9	13.0	1.77 (15.7)
DRE160MC4	11	59 (522)	590	640	18.3	16.8	7.28	3.51 (31.1)	36.6	33.6	14.6	1.76 (15.6)
DRE180S4	11	59 (522)	900	960	17.9	16.3	7.36	3.62 (32.0)	35.8	32.6	14.7	1.81 (16.0)
DRE180M4	15	81 (717)	1110	1170	24.0	22.1	8.86	3.67 (32.5)	48.0	44.2	17.7	1.83 (16.2)
DRE180L4	18.5	100 (885)	1300	1440	30.0	27.0	12.7	3.71 (32.8)	60.0	54.0	25.3	1.85 (16.4)
DRE180LC4	22	118 (1044)	1790	1930	35.5	33.2	12.6	3.56 (31.5)	71.0	66.4	25.2	1.78 (15.8)
DRE200L4	30	161 (1425)	2360	2500	49.5	45.4	19.0	3.54 (31.3)	99.0	90.9	38.0	1.77 (15.7)
DRE225S4	37	199 (1761)	2930	3160	59.0	57.2	15.1	3.48 (30.8)	118	114	30.3	1.74 (15.4)
DRE225M4	45	240 (2124)	3430	3660	71.0	66.5	24.4	3.61 (32.0)	142	133	48.7	1.80 (15.9)
DRE315K4	110	590 (5222)	18400	19500	169	157	63.2	3.76 (33.3)	338	314	126	1.88 (16.6)
DRE315S4	132	707 (6257)	22500	23600	205	202	43.4	3.49 (30.9)	410	405	87	1.75 (15.5)
DRE315S4	150	900 (7966)	22500	23600	225	218	61.2	4.14 (36.6)	450	435	122	2.07 (18.3)



Motor	P _m kW	M _N Nm (lb in)	Mass moment of inertia J _M 10 ⁻⁴ kgm ²		Star Δ (AC 460 V)				Double-star $\Delta\Delta$ (AC 230 V)			
			without brake	with brake	I _n	I _{q_n} ¹⁾	I _{d_n} ¹⁾	k _T ¹⁾	I _n	I _{q_n} ¹⁾	I _{d_n} ¹⁾	k _T ¹⁾
					A	A	A	Nm/A (lb in/A)	A	A	A	Nm/A (lb in/A)
DRE315M4	160	856 (7576)	27900	29000	240	232	60.7	3.69 (33.0)	480	464	121	1.84 (16.3)
DRE315M4	185	990 (8762)	27900	29000	275	264	81.0	3.75 (33.2)	550	528	162	1.87 (16.6)
DRE315L4	200	1070 (9470)	31900	33000	295	287	74	3.73 (33.0)	-	-	-	-
DRE315L4	225	1205 (10665)	31900	33000	335	325	73	3.71 (32.8)	-	-	-	-

1) Applies in the basic speed range up to n_{base}.



Motor Selection

Motor selection for asynchronous AC and servomotors (CFC)

8.3.24 DRE motor selection in double-star/star connection type (line AC 460 V / 60 Hz)

AC 230/460 V / 60 Hz motors in star connection

Assignment of MOVIDRIVE® MDX61B0005-5A3 ... MDX61B0110-503 (sizes 0 ... 2):

Motor voltage			MOVIDRIVE® MDX61B...-5_3 (AC 400/500 V units) in CFC operating modes (P700)										
AC 460 / 60 Hz			0005	0008	0011	0014	0015	0022	0030	0040	0055	0075	0110
DRE80M4 0.75 kW	M_{max}	Nm (lb in)	13.9 (123)	14 (124)			14 (124)						
	n_{base}	rpm	949	978			978						
DRE90M4 1.1 kW	M_{max}	Nm (lb in)	12.3 (109)	14 (124)	14 (124)		14 (124)	Note: The data is based on a line voltage of AC 460 V.					
	n_{base}	rpm	1195	1212	1324		1318						
DRE90L4 1.5 kW	M_{max}	Nm (lb in)		17.1 (151)	22.8 (202)	28 (248)	22 (195)	28 (248)					
	n_{base}	rpm		1119	1031	972	1043	978					
DRE100L4 2.2 kW	M_{max}	Nm (lb in)				27.6 (244)	20 (177)	28.5 (252)	36.7 (325)	40 (354)			
	n_{base}	rpm				1095	1177	1084	990	972			
DRE100LC4 3.0 kW	M_{max}	Nm (lb in)						24.8 (219)	32.2 (285)	40 (354)	40 (354)		
	n_{base}	rpm						1371	1306	1318	1441		
DRE100LC4 3.7 kW	M_{max}	Nm (lb in)						27 (239)	35.1 (310)	40 (354)	40 (354)		
	n_{base}	rpm						1353	1289	1394	1470		
DRE112M4 3.7 kW	M_{max}	Nm (lb in)						27.1 (240)	34.9 (309)	40 (354)			
	n_{base}	rpm						1503	1425	1464			
DRE112M4 4.5 kW	M_{max}	Nm (lb in)							34 (301)	40 (354)	40 (354)		
	n_{base}	rpm							1347	1406	1469		
DRE132S4	M_{max}	Nm (lb in)							34.6 (306)	47.9 (424)	55 (487)	55 (487)	
	n_{base}	rpm							1435	1357	1406	1450	
DRE132M4 5.5 kW	M_{max}	Nm (lb in)							35.4 (313)	48.8 (432)	64.8 (574)	83.2 (736)	110 (974)
	n_{base}	rpm							1538	1455	1352	1225	1044
DRE132M4 7.5 kW	M_{max}	Nm (lb in)								47.8 (423)	63.8 (565)	82.2 (728)	110 (974)
	n_{base}	rpm								1552	1474	1372	1215
DRE132MC4 7.5 kW	M_{max}	Nm (lb in)									62.7 (555)	81.9 (725)	110 (974)
	n_{base}	rpm									1313	1259	1250
DRE132MC4 9.2 kW	M_{max}	Nm (lb in)									61.3 (543)	80.6 (713)	110 (974)
	n_{base}	rpm									1381	1333	1342
DRE160S4 7.5 kW	M_{max}	Nm (lb in)									63.6 (563)	83 (735)	110 (974)
	n_{base}	rpm									1217	1168	1168
DRE160S4 9.2 kW	M_{max}	Nm (lb in)									61.2 (542)	80 (708)	110 (974)
	n_{base}	rpm									1305	1261	1252
DRE160M4 9.2 kW	M_{max}	Nm (lb in)									62.5 (553)	82.2 (728)	126 (1115)
	n_{base}	rpm									1296	1252	1147
DRE160M4 11 kW	M_{max}	Nm (lb in)										79.9 (707)	123 (1089)
	n_{base}	rpm										1344	1243



Motor voltage			MOVIDRIVE® MDX61B...-5_3 (AC 400/500 V units) in CFC operating modes (P700)										
AC 460 / 60 Hz			0005	0008	0011	0014	0015	0022	0030	0040	0055	0075	0110
DRE160MC4 11 kW	M_{max}	Nm (lb in)										80.4 (712)	123 (1089)
	n_{base}	rpm										1362	1283
DRE160MC4 15 kW	M_{max}	Nm (lb in)											117 (1036)
	n_{base}	rpm											1388
DRE180S4 11 kW	M_{max}	Nm (lb in)	Note: The data is based on a line voltage of AC 460 V.									83.1 (735)	128 (1133)
	n_{base}	rpm										1321	1221
DRE180S4 15 kW	M_{max}	Nm (lb in)											124 (1097)
	n_{base}	rpm											1265
DRE180M4 15 kW	M_{max}	Nm (lb in)											127 (1124)
	n_{base}	rpm											1265
DRE180M4 18.5 kW	M_{max}	Nm (lb in)											124 (1097)
	n_{base}	rpm											1421
DRE180L4 18.5 kW	M_{max}	Nm (lb in)											124 (1097)
	n_{base}	rpm											1324



Motor Selection

Motor selection for asynchronous AC and servomotors (CFC)

Assignment of MOVIDRIVE® MDX61B0150-503 ... MDX61B0750-503 (size 3 ... 5):

Motor voltage			MOVIDRIVE® MDX61B...-5_3 (AC 400/500 V units) in CFC operating modes (P700)						
AC 460 / 60 Hz			0150	0220	0300	0370	0450	0550	0750
DRE132MC4 9.2 kW	M _{max}	Nm (lb in)	110 (974)						
	n _{base}	rpm	1425						
DRE160S4 7.5 kW	M _{max}	Nm (lb in)	110 (974)						
	n _{base}	rpm	1204						
DRE160S4 9.2 kW	M _{max}	Nm (lb in)	110 (974)						
	n _{base}	rpm	1314						
DRE160M4 9.2 kW	M _{max}	Nm (lb in)	169 (1496)	200 (1770)					
	n _{base}	rpm	1028	949					
DRE160M4 11 kW	M _{max}	Nm (lb in)	165 (1460)	200 (1770)					
	n _{base}	rpm	1138	1054					
DRE160MC4 11 kW	M _{max}	Nm (lb in)	166 (1469)	200 (1770)					
	n _{base}	rpm	1199	1164					
DRE160MC4 15 kW	M _{max}	Nm (lb in)	159 (1407)	200 (1770)	200 (1770)				
	n _{base}	rpm	1322	1349	1388				
DRE180S4 11 kW	M _{max}	Nm (lb in)	172 (1522)	200 (1770)					
	n _{base}	rpm	1115	1052					
DRE180S4 15 kW	M _{max}	Nm (lb in)	169 (1496)	200 (1770)					
	n _{base}	rpm	1182	1165					
DRE180M4 15 kW	M _{max}	Nm (lb in)	172 (1522)	200 (1770)					
	n _{base}	rpm	1192	1211					
DRE180M4 18.5 kW	M _{max}	Nm (lb in)	169 (1496)	200 (1770)					
	n _{base}	rpm	1354	1427					
DRE180L4 18.5 kW	M _{max}	Nm (lb in)	170 (1505)	250 (2213)	328 (2903)	400 (3540)			
	n _{base}	rpm	1275	1178	1079	982			
DRE180L4 22 kW	M _{max}	Nm (lb in)	169 (1496)	248 (2195)	326 (2885)	397 (3514)	400 (3540)		
	n _{base}	rpm	1301	1205	1102	1009	1006		
DRE180LC4 22 kW	M _{max}	Nm (lb in)	164 (1452)	241 (2133)	316 (2797)	386 (3416)	400 (3540)		
	n _{base}	rpm	1311	1221	1125	1035	1016		
DRE180LC4 30 kW	M _{max}	Nm (lb in)		238 (2106)	314 (2779)	384 (3399)	400 (3540)		
	n _{base}	rpm		1308	1231	1155	1168		
DRE200L4	M _{max}	Nm (lb in)		234 (2071)	311 (2753)	381 (3372)	468 (4142)	552 (4886)	600 (5310)
	n _{base}	rpm		1259	1186	1113	1025	940	896
DRE225S4	M _{max}	Nm (lb in)		234 (2071)	308 (2726)	377 (3337)	460 (4071)	544 (4815)	600 (5310)
	n _{base}	rpm		1438	1353	1268	1166	1069	1007
DRE225M4	M _{max}	Nm (lb in)			314 (2779)	387 (3425)	476 (4213)	564 (4992)	600 (5310)
	n _{base}	rpm			1242	1198	1142	1081	1084

Note:

The data is based on a line voltage of AC 460 V.



Motor voltage			MOVIDRIVE® MDX61B...-5_3 (AC 400/500 V units) in CFC operating modes (P700)						
AC 460 / 60 Hz			0150	0220	0300	0370	0450	0550	0750
DRE315K4	M_{max}	Nm (lb in)	Note: The data is based on a line voltage of AC 460 V.						692 (6125)
	n_{base}	rpm							1294

Assignment of MOVIDRIVE® MDX61B0150-503 ... MDX61B0750-503 (size 6 ... 7):

Motor voltage			MOVIDRIVE® MDX61B...-5_3 (AC 400/500 V units) in CFC operating modes (P700)						
AC 460 V / 60 Hz			0900	1100	1320	1600	2000	2500	
DRE315K4	M_{max}	Nm (lb in)	926 (8196)	1100 (9736)	1386 (12267)	1600 (14161)	1600 (14161)		
	n_{base}	rpm	1272	1254	1223	1236	1399		
DRE315S4 132 kW	M_{max}	Nm (lb in)	876 (7753)	1036 (9169)	1299 (11497)	1563 (13834)	1600 (14161)		
	n_{base}	rpm	1401	1359	1286	1210	1213		
DRE315S4 150 kW	M_{max}	Nm (lb in)		1106 (9798)	1407 (12453)	1600 (14161)	1600 (14161)	1600 (14161)	
	n_{base}	rpm		1259	1241	1297	1548	1696	
DRE315M4 160 kW	M_{max}	Nm (lb in)		1083 (9585)	1364 (12072)	1643 (14542)	2089 (18489)	2400 (21242)	
	n_{base}	rpm		1420	1374	1325	1242	1191	
DRE315M4 185 kW	M_{max}	Nm (lb in)			1373 (12152)	1660 (14692)	2116 (18728)	2400 (21242)	
	n_{base}	rpm			1241	1223	1190	1246	
DRE315L4 200 kW	M_{max}	Nm (lb in)			1372 (12143)	1657 (14666)	2109 (18666)	2400 (21242)	
	n_{base}	rpm			1430	1398	1342	1357	
DRE315L4 225 kW	M_{max}	Nm (lb in)			1365 (12081)	1648 (14586)	2098 (18569)	2400 (21242)	
	n_{base}	rpm			1440	1408	1352	1362	

AC 230/460 V / 60 Hz motors in double-star connection

Assignment of MOVIDRIVE® MDX61B0005-5A3 ... MDX61B0110-503 (sizes 0 ... 2):

Motor voltage			MOVIDRIVE® MDX61B...-5_3 (AC 400/500 V units) in CFC operating modes (P700)										
AC 230 / 60 Hz			0005	0008	0011	0014	0015	0022	0030	0040	0055	0075	0110
DRE80M4 0.75 kW	M_{max}	Nm (lb in)		8 (71)	10.6 (94)	13.9 (123)	10.3 (91)	14 (124)	14 (124)				
	n_{base}	rpm		2554	2437	2279	2455	2308	2507				
DRE90M4 1.1 kW	M_{max}	Nm (lb in)				12.3 (109)	8.8 (78)	12.8 (113)	14 (124)	14 (124)			
	n_{base}	rpm				2595	2707	2578	2847	3093			
DRE90L4 1.5 kW	M_{max}	Nm (lb in)						14.3 (127)	18.9 (167)	26.5 (235)	28 (248)		
	n_{base}	rpm						2484	2396	2238	2425		
DRE100L4 2.2 kW	M_{max}	Nm (lb in)							17.2 (152)	24.3 (215)	32.6 (289)	40 (354)	40 (354)
	n_{base}	rpm							2548	2443	2314	2244	2320
DRE100LC4 3.7 kW	M_{max}	Nm (lb in)									31.1 (275)	40 (354)	40 (354)
	n_{base}	rpm									2794	2724	3275
DRE112M4 3.7 kW	M_{max}	Nm (lb in)								23.1 (204)	31 (274)	40 (354)	40 (354)
	n_{base}	rpm								3193	3071	2915	3173



Motor Selection

Motor selection for asynchronous AC and servomotors (CFC)

Motor voltage			MOVIDRIVE® MDX61B...-5_3 (AC 400/500 V units) in CFC operating modes (P700)										
AC 230 / 60 Hz			0005	0008	0011	0014	0015	0022	0030	0040	0055	0075	0110
DRE112M4 4.5 kW	M_{max}	Nm (lb in)									30.1 (275)	39.1 (346)	40 (354)
	n_{base}	rpm									2880	2763	3183
DRE132S4	M_{max}	Nm (lb in)										40 (354)	55 (487)
	n_{base}	rpm										2924	2944
DRE132M4 5.5 kW	M_{max}	Nm (lb in)										40.8 (361)	62.1 (550)
	n_{base}	rpm										3115	2885
DRE132M4 7.5 kW	M_{max}	Nm (lb in)											61.1 (541)
	n_{base}	rpm											3097
DRE132MC4 7.5 kW	M_{max}	Nm (lb in)											59.9 (530)
	n_{base}	rpm											2719
DRE132MC4 9.2 kW	M_{max}	Nm (lb in)											58.5 (518)
	n_{base}	rpm											2854
DRE160S4 7.5 kW	M_{max}	Nm (lb in)											60.8 (538)
	n_{base}	rpm											2531
DRE160S4 9.2 kW	M_{max}	Nm (lb in)	Note: The data is based on a line voltage of AC 460 V.										58.5 (518)
	n_{base}	rpm											2707
DRE160M4 9.2 kW	M_{max}	Nm (lb in)											59.7 (528)
	n_{base}	rpm											2671



Assignment of MOVIDRIVE® MDX61B0150-503 ... MDX61B0750-503 (size 3 ... 5):

Motor voltage			MOVIDRIVE® MDX61B...-5_3 (AC 400/500 V units) in CFC operating modes (P700)							
AC 230 / 60 Hz			0150	0220	0300	0370	0450	0550	0750	
DRE132S4	M _{max}	Nm (lb in)	55 (487)							
	n _{base}	rpm	3115							
DRE132M4 5.5 kW	M _{max}	Nm (lb in)	83.2 (736)	110 (974)						
	n _{base}	rpm	2631	2314						
DRE132M4 7.5 kW	M _{max}	Nm (lb in)	82.2 (728)	110 (974)						
	n _{base}	rpm	2905	2668						
DRE132MC4 7.5 kW	M _{max}	Nm (lb in)	81.9 (725)	110 (974)	110 (974)					
	n _{base}	rpm	2622	2617	2788					
DRE132MC4 9.2 kW	M _{max}	Nm (lb in)	80.6 (713)	110 (974)	110 (974)					
	n _{base}	rpm	2771	2771	3052					
DRE160S4 7.5 kW	M _{max}	Nm (lb in)	83 (735)	110 (974)	110 (974)					
	n _{base}	rpm	2443	2460	2614					
DRE160S4 9.2 kW	M _{max}	Nm (lb in)	80 (708)	110 (974)	110 (974)					
	n _{base}	rpm	2627	2601	2882					
DRE160M4 9.2 kW	M _{max}	Nm (lb in)	82.2 (728)	120 (1062)	158 (1398)	193 (1708)	200 (1770)			
	n _{base}	rpm	2597	2439	2267	2109	2074			
DRE160M4 11 kW	M _{max}	Nm (lb in)	79.9 (707)	117 (1036)	155 (1372)	189 (1673)	200 (1770)			
	n _{base}	rpm	2768	2632	2474	2324	2489			
DRE160MC4 11 kW	M _{max}	Nm (lb in)	80.4 (712)	118 (1044)	156 (1381)	190 (1682)	200 (1770)			
	n _{base}	rpm	2794	2685	2562	2434	2526			
DRE160MC4 15 kW	M _{max}	Nm (lb in)		112 (991)	149 (1319)	483 (4275)	200 (1770)	200 (1770)		
	n _{base}	rpm		2874	2781	2689	2821	2957		
DRE180S4 11 kW	M _{max}	Nm (lb in)	83.1 (735)	122 (1080)	161 (1425)	197 (1744)	200 (1770)			
	n _{base}	rpm	2716	2573	2410	2257	2257			
DRE180S4 15 kW	M _{max}	Nm (lb in)		119 (1053)	158 (1398)	193 (1708)	200 (1770)			
	n _{base}	rpm		2629	2513	2397	2533			
DRE180M4 15 kW	M _{max}	Nm (lb in)		121 (1071)	161 (1425)	197 (1744)	200 (1770)			
	n _{base}	rpm		2616	2510	2400	2560			
DRE180M4 18.5 kW	M _{max}	Nm (lb in)		118 (1044)	157 (1390)	193 (1708)	200 (1770)	200 (1770)		
	n _{base}	rpm		2915	2822	2722	2955	2985		
DRE180L4 18.5 kW	M _{max}	Nm (lb in)		118 (1044)	159 (1407)	196 (1735)	241 (2133)	286 (2531)	356 (3151)	
	n _{base}	rpm		2712	2646	2573	2477	2374	2211	
DRE180L4 22 kW	M _{max}	Nm (lb in)			158 (1398)	195 (1726)	240 (2124)	284 (2514)	353 (3124)	
	n _{base}	rpm			2692	2623	2530	2430	2267	
DRE180LC4 22 kW	M _{max}	Nm (lb in)			153 (1354)	189 (1673)	233 (2062)	276 (2443)	343 (3036)	
	n _{base}	rpm			2699	2629	2536	2433	2274	

Note:
The data is based on a line voltage of AC 460 V.



Motor Selection

Motor selection for asynchronous AC and servomotors (CFC)

Motor voltage			MOVIDRIVE® MDX61B...-5_3 (AC 400/500 V units) in CFC operating modes (P700)						
AC 230 / 60 Hz			0150	0220	0300	0370	0450	0550	0750
DRE180LC4 30 kW	M_{max}	Nm (lb in)				185 (1637)	230 (2062)	273 (2416)	341 (3018)
	n_{base}	rpm				2769	2696	2619	2493
DRE200L4	M_{max}	Nm (lb in)					226 (2000)	270 (2390)	338 (2992)
	n_{base}	rpm					2583	2513	2386
DRE225S4	M_{max}	Nm (lb in)					226 (2000)	270 (2390)	337 (2983)
	n_{base}	rpm					2765	2698	2584
DRE225M4	M_{max}	Nm (lb in)	Note: The data is based on a line voltage of AC 460 V.						342 (3027)
	n_{base}	rpm							2502

Assignment of MOVIDRIVE® MDX61B0150-503 ... MDX61B0750-503 (size 6 ... 7):

Motor voltage			MOVIDRIVE® MDX61B...-5_3 (AC 400/500 V units) in CFC operating modes (P700)					
AC 230 V / 60 Hz			0900	1100	1320	1600	2000	2500
DRE180L4 18.5 kW	M_{max}	Nm (lb in)	400 (3540)					
	n_{base}	rpm	2108					
DRE180L4 22 kW	M_{max}	Nm (lb in)	400 (3540)					
	n_{base}	rpm	2168					
DRE180LC4 22 kW	M_{max}	Nm (lb in)	400 (3540)					
	n_{base}	rpm	2138					
DRE180LC4 30 kW	M_{max}	Nm (lb in)	400 (3540)					
	n_{base}	rpm	2450					
DRE200L4	M_{max}	Nm (lb in)	446 (3947)	526 (4655)	600 (5310)			
	n_{base}	rpm	2185	2033	1901			
DRE225S4	M_{max}	Nm (lb in)	444 (3930)	523 (4629)	600 (5310)			
	n_{base}	rpm	2387	2241	2103			
DRE225M4	M_{max}	Nm (lb in)	454 (4018)	537 (4753)	600 (5310)			
	n_{base}	rpm	2376	2276	2264			
DRE315K4	M_{max}	Nm (lb in)				810 (7169)	1042 (9222)	1300 (11506)
	n_{base}	rpm				2600	2559	2511
DRE315S4	M_{max}	Nm (lb in)					1045 (9249)	1317 (11656)
	n_{base}	rpm					2554	2526
DRE315M4	M_{max}	Nm (lb in)						1286 (11382)
	n_{base}	rpm						2518



8.3.25 DRE motor selection in double-star connection (line AC 230 V / 60 Hz)

AC 230/460 V / 60 Hz motors in double-star connection

Motor voltage			MOVIDRIVE® MDX61B...-2_3 (AC 230 V units) in CFC operating modes (P700)								
AC 230 V / 60 Hz			0015	0022	0037	0055	0075	0110	0150	0220	0300
DRE80S4	M _{max}	Nm (lb in)	14 (124)								
	n _{base}	rpm	855								
DRE80M4 0.75 kW	M _{max}	Nm (lb in)	14 (124)								
	n _{base}	rpm	978								
DRE80M4 1.1 kW	M _{max}	Nm (lb in)	14 (124)								
	n _{base}	rpm	1277								
DRE90M4 1.1 kW	M _{max}	Nm (lb in)	14 (124)								
	n _{base}	rpm	1289								
DRE90M4 1.5 kW	M _{max}	Nm (lb in)	14 (124)								
	n _{base}	rpm	1365								
DRE90L4 1.5 kW	M _{max}	Nm (lb in)	19.9 (176)	23.8 (211)	28 (248)						
	n _{base}	rpm	1078	1013	990						
DRE90L4 2.2 kW	M _{max}	Nm (lb in)	17.9 (158)	21.6 (191)	28 (248)						
	n _{base}	rpm	1212	1154	1142						
DRE100M4	M _{max}	Nm (lb in)		20.5 (181)	35.9 (318)	40 (354)					
	n _{base}	rpm		1400	1218	1236					
DRE100L4 2.2 kW	M _{max}	Nm (lb in)	18 (159)	21.8 (193)	38.1 (337)	40 (354)					
	n _{base}	rpm	1201	1160	972	972					
DRE100L4 3.7 kW	M _{max}	Nm (lb in)			35.7 (316)	40 (354)					
	n _{base}	rpm			1418	1564					
DRE100LC4 3.7 kW	M _{max}	Nm (lb in)			36.5 (323)	40 (354)					
	n _{base}	rpm			1283	1464					
DRE112M4 3.7 kW	M _{max}	Nm (lb in)			36.2 (320)	40 (354)					
	n _{base}	rpm			1411	1469					
DRE112M4 4.5 kW	M _{max}	Nm (lb in)			35.2 (312)	40 (354)					
	n _{base}	rpm			1337	1465					
DRE132S4	M _{max}	Nm (lb in)			36 (319)	55 (487)	55 (487)				
	n _{base}	rpm			1430	1323	1450				
DRE132M4 5.5 kW	M _{max}	Nm (lb in)			36.7 (325)	56.8 (503)	75.3 (666)	109 (965)	110 (974)		
	n _{base}	rpm			1533	1406	1279	1049	1044		
DRE132M4 7.5 kW	M _{max}	Nm (lb in)				55.8 (494)	74.3 (658)	108 (956)	110 (974)		
	n _{base}	rpm				1513	1416	1225	1215		
DRE132MC4 7.5 kW	M _{max}	Nm (lb in)				54.2 (480)	73.7 (652)	109 (965)	110 (974)		
	n _{base}	rpm				1333	1279	1176	1279		

Note:
The data is based on a line voltage of AC 230 V.



Motor Selection

Motor selection for asynchronous AC and servomotors (CFC)

Motor voltage			MOVIDRIVE® MDX61B...-2_3 (AC 230 V units) in CFC operating modes (P700)									
AC 230 V / 60 Hz			0015	0022	0037	0055	0075	0110	0150	0220	0300	
DRE132MC4 9.2 kW	M_{max}	Nm (lb in)					72.4 (641)	107 (947)	110 (974)			
	n_{base}	rpm					1357	1259	1401			
DRE160S4 7.5 kW	M_{max}	Nm (lb in)				55.2 (489)	74.8 (662)	110 (974)	110 (974)			
	n_{base}	rpm				1239	1186	1094	1190			
DRE160S4 9.2 kW	M_{max}	Nm (lb in)					72 (637)	106 (938)	110 (974)	110 (974)		
	n_{base}	rpm					1283	1190	1309	1314		
DRE160M4 9.2 kW	M_{max}	Nm (lb in)					73.8 (653)	109 (965)	142 (1257)	200 (1770)		
	n_{base}	rpm					1274	1186	1103	949		
DRE160M4 11 kW	M_{max}	Nm (lb in)					71.7 (635)	107 (947)	139 (1230)	200 (1770)		
	n_{base}	rpm					1362	1283	1204	1054		
DRE160MC4 11 kW	M_{max}	Nm (lb in)					72 (637)	107 (947)	140 (1239)	200 (1770)		
	n_{base}	rpm					1379	1314	1252	1147		
DRE160MC4 15 kW	M_{max}	Nm (lb in)						101 (894)	133 (1177)	200 (1770)	200 (1770)	
	n_{base}	rpm						1410	1366	1261	1362	
DRE180S4 11 kW	M_{max}	Nm (lb in)					74.4 (658)	111 (982)	144 (1275)	200 (1770)		
	n_{base}	rpm					1338	1261	1182	1052		
DRE180S4 15 kW	M_{max}	Nm (lb in)						107 (947)	141 (1248)	200 (1770)		
	n_{base}	rpm						1291	1235	1152		
DRE180M4 15 kW	M_{max}	Nm (lb in)						111 (982)	145 (1283)	200 (1770)		
	n_{base}	rpm						1251	1202	1155		
DRE180M4 18.5 kW	M_{max}	Nm (lb in)							142 (1257)	200 (1770)	200 (1770)	
	n_{base}	rpm							1334	1308	1404	
DRE180L4 18.5 kW	M_{max}	Nm (lb in)							143 (1266)	220 (1947)	264 (2337)	
	n_{base}	rpm							1231	1155	1109	
DRE180L4 22 kW	M_{max}	Nm (lb in)							141 (1248)	217 (1921)	260 (2301)	
	n_{base}	rpm							1245	1172	1125	
DRE180LC4 22 kW	M_{max}	Nm (lb in)								213 (1885)	256 (2266)	
	n_{base}	rpm								1205	1162	
DRE180LC4 30 kW	M_{max}	Nm (lb in)								207 (1832)	249 (2204)	
	n_{base}	rpm								1258	1225	
DRE200L4	M_{max}	Nm (lb in)	Note: The data is based on a line voltage of AC 230 V.								201 (1779)	243 (2151)
	n_{base}	rpm									1289	1251
DRE225S4	M_{max}	Nm (lb in)									243 (2151)	
	n_{base}	rpm									1338	



8.3.26 Motor tables DV series AC motors (characteristic value with double-star/star connection AC 230/460 V / 60 Hz)

Motor	P _m kW	M _N Nm (lb in)	Mass moment of inertia J _M without brake with brake		Star (AC 460 V)				Double-star (AC 230 V)			
			10 ⁻⁴ kgm ²		I _n A	I _{q_n} ¹⁾ A	I _{d_n} ¹⁾ A	k _T ¹⁾ Nm/A (lb in/A)	I _n A	I _{q_n} ¹⁾ A	I _{d_n} ¹⁾ A	k _T ¹⁾ Nm/A (lb in/A)
DV250M4	55	296 (2620)	6300	6600/6730 ²⁾	87	78.5	37.6	3.77 (33.4)	174	157	75.2	1.89 (16.7)
DV280S4	75	402 (3558)	8925	9225/9355 ²⁾	118	107	50.8	3.77 (33.4)	236	213	102	1.89 (16.7)
DV280M4	90	580 (5133)	14500	3)	162	153	51.7	3.79 (33.5)	324	306	103	1.89 (16.7)

- 1) Applies in the basic speed range up to n_{base}.
- 2) Double disk brake
- 3) On request

8.3.27 DV motor selection in double-star/star connection type (line AC 460 V / 60 Hz)

AC 230/460 V / 60 Hz motors in star connection

Motor voltage AC 460 V / 60 Hz		MOVIDRIVE® MDX61B...-5_3 (AC 400/500 V units) in CFC operating modes (P700)									
		0150	0220	0300	0370	0450	0550	0750	0900	1100	1320
DV250M4	M _{max} Nm (lb in)						576 (5100)	641 (5670)			
	n _{base} rpm						1261	1370			
DV280S4	M _{max} Nm (lb in)							711 (6290)	871 (7710)	871 (7710)	
	n _{base} rpm							1421	1478	1664	
D280M4	M _{max} Nm (lb in)							712 (6300)	946 (8370)	1045 (9249)	
	n _{base} rpm							1338	1318	1382	

Note: The maximum torque M_{max} is limited to 180 % of the rated motor torque M_N. The data is based on a line voltage of AC 460 V.

AC 230/460 V / 60 Hz motors in double-star connection

Motor voltage AC 230 V / 60 Hz		MOVIDRIVE® MDX61B...-5_3 (AC 400/500 V units) in CFC operating modes (P700)									
		0150	0220	0300	0370	0450	0550	0750	0900	1100	1320
DV250M4	M _{max} Nm (lb in)								459 (4062)	547 (4841)	641 (5673)
	n _{base} rpm								2656	2630	2771
DV280S4	M _{max} Nm (lb in)									533 (4717)	681 (6027)
	n _{base} rpm									2963	2925

Note: The maximum torque M_{max} is limited to 180 % of the rated motor torque M_N. The data is based on a line voltage of AC 460 V.



Motor Selection

Motor selection for synchronous servomotors (SERVO)

8.4 Motor selection for synchronous servomotors (SERVO)

	INFORMATION
	<p>The torque limit (M limit) is set automatically by the startup function of the MOVITOOLS[®] MotionStudio engineering software. Do not increase this automatically set value!</p> <p>We recommend always using the latest version of MOVITOOLS[®] MotionStudio for startup. The latest MOVITOOLS[®] MotionStudio version can be downloaded from our homepage (www.sew-eurodrive.de).</p>

8.4.1 Motor characteristics

The demands made on a servo drive include speed dynamics, stable speed, and positioning accuracy. DS/CM/CMD/CMP motors with MOVIDRIVE[®] meet these requirements.

Technically speaking, these are synchronous motors with permanent magnets on the rotor and a mounted resolver. The required characteristics, namely a constant torque over a wide speed range (up to 6000 rpm), a high speed and control range and a high overload capacity, are achieved using control with MOVIDRIVE[®]. The mass moment of inertia of the servomotor is lower than that of the asynchronous motor. This means it is ideally suited to applications requiring dynamic speeds. The following figures shows the speed/torque characteristic curve of DS/CM/CMD/CMP servomotors.

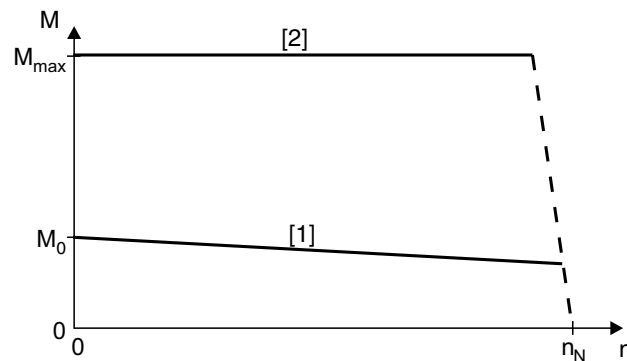

1477399307

[1] Continuous torque

[2] Maximum torque

M_0 and M_{max} are determined by the motor. The attainable M_{max} can also be less, depending on the inverter.

Refer to the motor selection tables (DS/CM/CMD/CMP) the values for M_0 .

Refer to the motor selection tables (DS/CM/CMD/CMP) for the values for M_{max} .



8.4.2 Basic recommendations

For SEW motors, the motor data required for the SERVO operating modes is stored in MOVIDRIVE®.

Speed is the correcting variable in the SERVO operating modes with speed control. Torque is the correcting variable in the SERVO operating modes with torque control (SERVO & M-CONTROL).

SERVO mode with speed control

There is no need to differentiate between the load types quadratic, dynamic and static when performing project planning for the SERVO operating mode. Project planning for a synchronous motor is carried out in accordance with the following requirements:

1. Effective torque requirement at average application speed.

$$M_{\text{eff}} < M_0$$

The point must lie below the characteristic curve for the continuous torque (figure 37, curve 1). The continuous torque of the CM series can be increased by 40 % by forced cooling if this operating point lies above the characteristic curve for self-cooling.

2. Maximum torque needed across the speed curve.

$$M_{\text{max}} < M_{\text{dyn_mot}}$$

This operating point must lie below the characteristic curve for the maximum torque of the motor/MOVIDRIVE® combination (figure 37, curve 2).

3. Maximum speed

The maximum speed must not be configured higher than the rated speed of the motor. Planetary gear units should be used for speeds greater than 3000 rpm as a result of the high input speed.

$$n_{\text{max}} \leq n_N$$

SERVO mode with torque control (SERVO & M-CTRL.)

This operating mode allows the servomotor to be controlled directly with torque control. The setpoint sources of the speed-controlled SERVO mode can also be used for torque control. All speed setpoint sources (except for bus setpoints) are interpreted as current setpoint sources. Assign "Current" to a process data word for fieldbus control. The settings for evaluating the analog input (→ P11_, parameter description) also remain in effect. The fixed setpoints (P16_, P17_) can be entered either in the unit (rpm) or (%I_{N_inverter}) (→ MOVITOOLS® MotionStudio).

The following relationship exists between the units:

$$3000 \text{ rpm} \triangleq 150\% \text{ nominal inverter current}$$

The torque at the output shaft of the servomotor can be calculated using the following formula:

$$M = \frac{M_0}{I_0} \times \frac{150\% \times I_{N_inverter}}{3000 \text{ 1/min}} \times n_{\text{setpoint}}$$

1477428491

M_0 Continuous static torque according to the motor tables DS/CM/CMD/CMP
 I_0 Continuous static torque according to the motor tables DS/CM/CMD/CMP



Motor Selection

Motor selection for synchronous servomotors (SERVO)

8.4.3 Motor table DS/CM

Characteristic values at $U_{max} = AC 230 V / AC 400 V$

n_N rpm	Motor	Without forced cooling fan			With forced cooling fan VR					Mass moment of inertia J_M	
		M_0 Nm (lb in)	$I_0^{1)}$ A	$I_0^{2)}$ A	M_{0_VR} Nm (lb in)	$I_{0_VR}^{1)}$ A	$I_{0_VR}^{2)}$ A	$I_{max}^{1)}$ A	$I_{max}^{2)}$ A	without brake 10^{-4} kgm^2	with brake 10^{-4} kgm^2
2000	CM71S	5.0 (44)	2.2	3.95	7.3 (65)	3.2	5.7	8.8	15.8	4.85	6.89
	CM71M	6.5 (58)	3.0	5.3	9.4 (83)	4.2	7.7	12.0	21.0	6.27	8.31
	CM71L	9.5 (84)	4.2	7.4	13.8 (122)	6.1	10.7	16.8	29.5	9.1	11.1
	CM90S	11.0 (97.4)	4.9	8.7	16.0 (142)	7.1	12.6	19.6	35.0	14.3	19.8
	CM90M	14.5 (128)	6.9	12.1	21.0 (186)	10.0	17.5	28.0	48.5	18.6	24.1
	CM90L	21.0 (186)	9.9	17.1	30.5 (270)	14.4	25.0	40.0	68.0	27.1	32.6
	CM112S	23.5 (208)	10.0	18.0	34.0 (301)	14.5	26.0	40.0	72	67.4	87.5
	CM112M	31.0 (274)	13.5	24.5	45.0 (398)	19.6	35.5	54.0	98	87.4	108
	CM112L	45.0 (398)	20.0	35.5	65.0 (575)	29.0	51.0	80.0	142	128	148
CM112H	68.0 (602)	30.5	52.0	95.0 (841)	42.5	73.0	122	208	189	209	
3000	DS56M	1.0 (8.9)	1.65	1.65	-	-	-	6.6	6.6	0.47	0.85
	DS56L	2.0 (18)	2.4	2.4	-	-	-	9.6	9.6	0.82	1.2
	DS56H	4.0 (36)	2.8	4.7	-	-	-	11.2	19	1.53	1.88
	CM71S	5.0 (44)	3.3	5.9	7.3 (65)	4.8	8.6	13.2	23.5	4.85	6.89
	CM71M	6.5 (58)	4.3	7.6	9.4 (83)	6.2	11.0	17.2	30.5	6.27	8.31
	CM71L	9.5 (84)	6.2	11.1	13.8 (122)	9.0	16.1	25.0	44.5	9.1	11.1
	CM90S	11.0 (97.4)	7.3	12.7	16.0 (142)	10.6	18.4	30.0	51	14.3	19.8
	CM90M	14.5 (128)	10.1	17.4	21.0 (186)	14.6	25.0	40.0	70	18.6	24.1
	CM90L	21.0 (186)	14.4	25.5	30.5 (270)	21.0	37.0	58.0	102	27.1	32.6
	CM112S	23.5 (208)	15.0	27.0	34.0 (301)	22.0	39.0	60.0	108	67.4	87.5
	CM112M	31.0 (274)	20.5	35.0	45.0 (398)	30.0	51.0	82.0	140	87.4	108
	CM112L	45.0 (398)	30.0	48.0	65.0 (575)	44.0	70.0	120	192	128	148
CM112H	68.0 (602)	43.0	73.0	95.0 (841)	60.0	102	172	292	189	209	
4500	DS56M	1.0 (8.9)	1.65	1.65	-	-	-	6.6	6.6	0.47	0.85
	DS56L	2.0 (18)	2.4	-	-	-	-	9.6	-	0.82	1.2
	DS56H	4.0 (36)	4.0	-	-	-	-	16.0	-	1.53	1.88
	CM71S	5.0 (44)	4.9	8.5	7.3 (65)	7.2	12.3	20.0	34	4.85	6.89
	CM71M	6.5 (58)	6.6	11.3	9.4 (83)	9.6	16.4	26.0	45	6.27	8.31
	CM71L	9.5 (84)	9.6	17.1	13.8 (122)	14.0	25.0	38.0	68	9.1	11.1
	CM90S	11.0 (97.4)	11.1	18.9	16.0 (142)	16.2	27.5	44.0	76	14.3	19.8
	CM90M	14.5 (128)	14.7	26.0	21.0 (186)	21.5	37.5	59.0	104	18.6	24.1
	CM90L	21.0 (186)	21.6	39.0	30.5 (270)	31.5	57	86.0	156	27.1	32.6
	CM112S	23.5 (208)	22.5	38.5	34.0 (301)	32.5	56	90.0	154	67.4	87.5
	CM112M	31.0 (274)	30.0	54.0	45.0 (398)	44.0	78	120	216	87.4	108
	CM112L	45.0 (398)	46.0	78.0	65.0 (575)	67.0	113	184	312	128	148
CM112H	68.0 (602)	66.0	-	95.0 (841)	92.0	-	264	-	189	209	
6000	DS56M	1.0 (8.9)	1.65	-	-	-	-	6.6	-	0.47	0.85
	DS56L	2.0 (18)	2.75	-	-	-	-	11.0	-	0.82	1.2
	DS56H	4.0 (36)	5.3	-	-	-	-	21.0	-	1.53	1.88
	CM71S	5.0 (44)	6.5	11.6	7.3 (65)	7.2	16.8	26.0	46.5	4.85	6.89
	CM71M	6.5 (58)	8.6	14.1	9.4 (83)	9.6	20.5	34.0	56	6.27	8.31
	CM71L	9.5 (84)	12.5	21.5	13.8 (122)	14.0	31.0	50.0	86	9.1	11.1
	CM90S	11.0 (97.4)	14.5	23.5	16.0 (142)	16.2	34.0	58.0	94	14.3	19.8
	CM90M	14.5 (128)	19.8	37.0	21.0 (186)	21.5	54	79.0	148	18.6	24.1
CM90L	21.0 (186)	29.5	51.0	30.5 (270)	31.5	74	118.0	204	27.1	32.6	

1) For DS/CM synchronous servomotors with AC 400 V system voltage

2) For DS/CM synchronous servomotors with AC 230 V system voltage



	INFORMATION
Additional project planning notes and information about the type DS/CM synchronous servomotors can be found in the "Servo Gearmotors" catalog, which can be ordered from SEW-EURODRIVE.	

8.4.4 DS/CM motor selection (line AC 400 V / 50 Hz)

1. Nominal speed $n_N = 2000$ rpm:

Motor			MOVIDRIVE® MDX61B...-5_3 (AC 400/500 V units) in the SERVO operating modes (P700)															
			0005	0008	0011	0014	0015	0022	0030	0040	0055	0075	0110	0150	0220	0300	0370	0450
CM71S	M_{max}	Nm	8.9	10.5	13.1	15.6	12.7	15.9	16.5									
		(lb in)	(79)	(93)	(116)	(138)	(112)	(141)	(146)									
CM71M	M_{max}	Nm	8.6	10.3	13.1	16.2	12.7	16.7	19.8	21.5								
		(lb in)	(76)	(91)	(116)	(143)	(112)	(148)	(175)	(190)								
CM71L	M_{max}	Nm		10.8	13.9	17.7	13.5	18.2	22.5	28.4	31.4							
		(lb in)		(96)	(123)	(157)	(119)	(161)	(199)	(251)	(278)							
CM90S	M_{max}	Nm			13.9	17.8	13.4	18.4	23.2	30.6	38.2	39.4						
		(lb in)			(123)	(158)	(119)	(163)	(205)	(271)	(338)	(349)						
CM90M	M_{max}	Nm				16.8	12.6	17.3	21.9	29.5	38.0	46.9	52.5					
		(lb in)				(149)	(112)	(153)	(194)	(261)	(336)	(415)	(465)					
CM90L	M_{max}	Nm						17.5	22.2	30.1	39.3	49.6	70.3	75.8				
		(lb in)							(155)	(196)	(266)	(348)	(439)	(622)	(671)			
CM112S	M_{max}	Nm						19.3	24.6	33.4	43.6	54.8	76.2	81.9				
		(lb in)							(171)	(218)	(296)	(386)	(485)	(674)	(725)			
CM112M	M_{max}	Nm							23.9	32.6	42.9	54.7	79.3	99.6	108.0			
		(lb in)								(212)	(289)	(380)	(484)	(702)	(882)	(956)		
CM112L	M_{max}	Nm								42.0	53.9	80.3	104.9	141.5	156.8			
		(lb in)									(372)	(477)	(711)	(928)	(1252)	(1388)		
CM112H	M_{max}	Nm									53.2	80.1	106.5	150.3	189.2	220.1	237.0	
		(lb in)										(471)	(709)	(943)	(1330)	(1675)	(1948)	(2100)



Motor Selection

Motor selection for synchronous servomotors (SERVO)

2. Nominal speed $n_N = 3000$ rpm:

Motor			MOVIDRIVE® MDX61B...-5_3 (AC 400/500 V units) in the SERVO operating modes (P700)								
			0005	0008	0011	0014	0015	0022	0030	0040	0055
DS56M	M_{max}	Nm	2.4	2.8	3.6	3.8	3.5	3.8			
		(lb in)	(21)	(25)	(32)	(34)	(31)	(34)			
DS56L	M_{max}	Nm	3.3	4.0	5.1	6.4	4.9	6.6	7.6		
		(lb in)	(29)	(35)	(45)	(57)	(43)	(58)	(67)		
DS56H	M_{max}	Nm	5.7	6.8	8.8	11.2	8.5	11.5	14.3	15.0	
		(lb in)	(50)	(60)	(78)	(99)	(75)	(102)	(127)	(133)	
CM71S	M_{max}	Nm	6.0	7.2	9.2	11.6	8.9	11.9	14.3	16.5	
		(lb in)	(53)	(64)	(81)	(103)	(79)	(105)	(127)	(146)	
CM71M	M_{max}	Nm		7.2	9.3	11.9	9.0	12.2	15.1	19.1	21.5
		(lb in)		(64)	(82)	(105)	(80)	(108)	(134)	(169)	(190)
CM71L	M_{max}	Nm			9.5	12.2	9.2	12.6	15.9	21.0	26.2
		(lb in)			(84)	(108)	(81)	(112)	(141)	(186)	(232)
CM90S	M_{max}	Nm				12.0	9.0	12.4	15.7	21.2	27.4
		(lb in)				(106)	(80)	(110)	(139)	(188)	(243)
CM90M	M_{max}	Nm						11.8	15.0	20.4	26.6
		(lb in)						(104)	(133)	(181)	(235)
CM90L	M_{max}	Nm								20.7	27.3
		(lb in)								(183)	(242)
CM112S	M_{max}	Nm								22.2	29.3
		(lb in)								(196)	(259)
CM112M	M_{max}	Nm									28.2
		(lb in)									(250)

Motor			MOVIDRIVE® MDX61B...-5_3 (AC 400/500 V units) in the SERVO operating modes (P700)								
			0075	0110	0150	0220	0300	0370	0450	0550	0750
CM71L	M_{max}	Nm	30.8	31.5							
		(lb in)	(273)	(279)							
CM90S	M_{max}	Nm	34.0	39.2							
		(lb in)	(301)	(347)							
CM90M	M_{max}	Nm	33.7	47.8	51.6						
		(lb in)	(298)	(423)	(457)						
CM90L	M_{max}	Nm	34.7	51.1	65.6	75.6					
		(lb in)	(307)	(452)	(581)	(669)					
CM112S	M_{max}	Nm	37.4	54.8	69.8	81.9					
		(lb in)	(331)	(485)	(618)	(725)					
CM112M	M_{max}	Nm	36.2	54.0	70.7	95.7	108.0				
		(lb in)	(320)	(478)	(626)	(847)	(956)				
CM112L	M_{max}	Nm	35.8	53.9	71.6	101.0	126.9	147.4	156.8		
		(lb in)	(317)	(477)	(634)	(894)	(1123)	(1305)	(1388)		
CM112H	M_{max}	Nm		56.6	75.7	108.6	139.9	167.0	197.1	223.2	237.0
		(lb in)		(501)	(670)	(961)	(1238)	(1478)	(1744)	(1975)	(2098)



3. Nominal speed $n_N = 4500$ rpm:

Motor			MOVIDRIVE® MDX61B...-5_3 (AC 400/500 V units) in the SERVO operating modes (P700)							
			0005	0008	0011	0014	0015	0022	0030	0040
DS56M	M_{max}	Nm	2.4	2.8	3.6	3.8	3.5	3.8		
		(lb in)	(21)	(25)	(32)	(34)	(31)	(34)		
DS56L	M_{max}	Nm	3.3	4.0	5.1	6.4	4.9	6.6	7.6	
		(lb in)	(29)	(35)	(45)	(57)	(43)	(58)	(67)	
DS56H	M_{max}	Nm	4.0	4.8	6.2	7.9	6.0	8.2	10.3	13.7
		(lb in)	(35)	(42)	(55)	(70)	(53)	(73)	(91)	(121)
CM71S	M_{max}	Nm			6.3	8.1	6.1	8.3	10.4	13.4
		(lb in)			(56)	(72)	(54)	(73)	(92)	(119)
CM71M	M_{max}	Nm				7.9	5.9	8.1	10.2	13.6
		(lb in)				(70)	(52)	(72)	(90)	(120)
CM71L	M_{max}	Nm						8.2	10.4	14.0
		(lb in)						(73)	(92)	(124)
CM90S	M_{max}	Nm							10.4	14.1
		(lb in)							(92)	(125)
CM90M	M_{max}	Nm								14.0
		(lb in)								(124)

Motor			MOVIDRIVE® MDX61B...-5_3 (AC 400/500 V units) in the SERVO operating modes (P700)										
			0055	0075	0110	0150	0220	0300	0370	0450	0550	0750	0900
DS56H	M_{max}	Nm	15.2										
		(lb in)	(135)										
CM71S	M_{max}	Nm	16.1	16.5									
		(lb in)	(142)	(146)									
CM71M	M_{max}	Nm	17.1	20.3	21.3								
		(lb in)	(151)	(180)	(189)								
CM71L	M_{max}	Nm	18.1	22.5	30.3	31.2							
		(lb in)	(160)	(199)	(268)	(276)							
CM90S	M_{max}	Nm	18.4	23.4	33.6	39.2							
		(lb in)	(163)	(207)	(297)	(347)							
CM90M	M_{max}	Nm	18.4	23.5	34.6	44.5	52.1						
		(lb in)	(163)	(208)	(306)	(394)	(461)						
CM90L	M_{max}	Nm	18.2	23.3	34.7	45.8	63.4	75.0					
		(lb in)	(161)	(206)	(307)	(405)	(561)	(664)					
CM112S	M_{max}	Nm	19.5	25.0	37.4	49.2	67.5	81.9					
		(lb in)	(173)	(221)	(331)	(435)	(597)	(725)					
CM112M	M_{max}	Nm		24.6	37.1	49.4	69.6	87.4	101.5	108.0			
		(lb in)		(218)	(328)	(437)	(616)	(774)	(898)	(956)			
CM112L	M_{max}	Nm			35	46.8	67.2	86.9	104.1	123.5	140.7	156.8	
		(lb in)			(310)	(414)	(595)	(769)	(921)	(1093)	(1245)	(1388)	
CM112H	M_{max}	Nm				70.9	92.5	112.1	135.5	157.7	189.4	231.6	237.0
		(lb in)				(628)	(819)	(992)	(1199)	(1396)	(1676)	(2050)	(2098)



Motor Selection

Motor selection for synchronous servomotors (SERVO)

4. Nominal speed $n_N = 6000$ rpm:

Motor		MOVIDRIVE® MDX61B...-5_3 (AC 400/500 V units) in the SERVO operating modes (P700)																
		0005	0008	0011	0014	0015	0022	0030	0040	0055	0075	0110	0150	0220	0300	0370	0450	
DS56M	M_{max}	Nm (lb in)	2.4 (21)	2.8 (25)	3.6 (32)	3.8 (34)	3.5 (31)	3.8 (34)										
DS56L	M_{max}	Nm (lb in)	2.9 (26)	3.5 (31)	4.5 (40)	5.7 (50)	4.3 (38)	5.8 (51)	7.3 (65)	7.6 (67)								
DS56H	M_{max}	Nm (lb in)			4.7 (42)	6.0 (53)	4.5 (40)	6.2 (55)	7.9 (70)	10.5 (93)	13.6 (120)	15.1 (134)						
CM71S	M_{max}	Nm (lb in)				6.1 (54)	4.6 (41)	6.3 (56)	8.0 (71)	10.6 (94)	13.3 (118)	15.8 (140)	16.5 (146)					
CM71M	M_{max}	Nm (lb in)						6.2 (55)	7.9 (70)	10.6 (94)	13.7 (121)	16.8 (149)	21.3 (189)					
CM71L	M_{max}	Nm (lb in)							8.0 (71)	10.8 (96)	14.1 (125)	17.9 (158)	25.2 (223)	30.7 (272)	31.4 (278)			
CM90S	M_{max}	Nm (lb in)								10.8 (96)	14.2 (126)	18.1 (160)	26.6 (235)	34.2 (303)	39.4 (349)			
CM90M	M_{max}	Nm (lb in)									13.7 (121)	17.5 (155)	26.1 (231)	34.3 (304)	46.9 (415)	51.9 (459)		
CM90L	M_{max}	Nm (lb in)										17.1 (151)	25.6 (227)	33.9 (300)	48.0 (425)	60.9 (539)	71.3 (631)	75.2 (666)



8.4.5 DS/CM motor selection (line AC 230 V)

Nominal speed $n_N = 2000$ rpm:

Motor			MOVIDRIVE® MDX61B...-2_3 (AC 230 V units) in the SERVO operating modes (P700)								
			0015	0022	0037	0055	0075	0110	0150	0220	0300
CM71S	M_{max}	Nm	12.9	14.6	16.5						
		(lb in)	(114)	(129)	(146)						
CM71M	M_{max}	Nm	13.1	15.1	21.4						
		(lb in)	(116)	(134)	(189)						
CM71L	M_{max}	Nm	14.0	16.3	25.6	31.3					
		(lb in)	(124)	(144)	(227)	(277)					
CM90S	M_{max}	Nm	13.8	16.2	26.8	38.0	39.6				
		(lb in)	(122)	(143)	(237)	(336)	(350)				
CM90M	M_{max}	Nm	13.1	15.4	25.8	38.2	48.1	52.0			
		(lb in)	(116)	(136)	(228)	(338)	(426)	(460)			
CM90L	M_{max}	Nm		15.8	26.6	40.0	51.9	70.9	74.9		
		(lb in)		(140)	(235)	(354)	(459)	(628)	(663)		
CM112S	M_{max}	Nm			28.3	42.7	55.1	74.7	81.9		
		(lb in)			(250)	(378)	(488)	(661)	(725)		
CM112M	M_{max}	Nm			27.4	41.6	54.6	76.8	94.4	108.0	
		(lb in)			(243)	(368)	(483)	(680)	(836)	(956)	
CM112L	M_{max}	Nm				41.7	55.0	79.2	100.2	139.3	156.8
		(lb in)				(369)	(487)	(701)	(887)	(1233)	(1388)
CM112H	M_{max}	Nm					56.6	82.2	105.5	153	177.9
		(lb in)					(501)	(728)	(934)	(1350)	(1575)

Nominal speed $n_N = 3000$ rpm:

Motor			MOVIDRIVE® MDX61B...-2_3 (AC 230 V units) in the SERVO operating modes (P700)								
			0015	0022	0037	0055	0075	0110	0150	0220	0300
DS56M	M_{max}	Nm	3.8								
		(lb in)	(34)								
DS56L	M_{max}	Nm	7.6								
		(lb in)	(67)								
DS56H	M_{max}	Nm	9.2	10.7	15.3						
		(lb in)	(81)	(95)	(135)						
CM71S	M_{max}	Nm	9.1	10.6	15.8	16.5					
		(lb in)	(81)	(94)	(140)	(146)					
CM71M	M_{max}	Nm	9.3	10.9	17.2	21.5					
		(lb in)	(82)	(97)	(152)	(190)					
CM71L	M_{max}	Nm	9.4	11.0	18.2	25.8	31.0	31.4			
		(lb in)	(83)	(97)	(161)	(228)	(274)	(278)			
CM90S	M_{max}	Nm	9.5	11.2	18.7	27.7	35.1	39.5			
		(lb in)	(84)	(99)	(166)	(245)	(311)	(350)			
CM90M	M_{max}	Nm			18.1	27.2	35.3	48.4	52.2		
		(lb in)			(160)	(241)	(312)	(428)	(462)		
CM90L	M_{max}	Nm			17.9	27.1	35.5	50.5	63.1	75.2	
		(lb in)			(158)	(240)	(314)	(447)	(558)	(666)	
CM112S	M_{max}	Nm			18.8	28.7	37.7	53.4	66.3	81.9	
		(lb in)			(166)	(254)	(334)	(473)	(587)	(725)	
CM112M	M_{max}	Nm				29.1	38.4	55.3	69.9	97.0	108.0
		(lb in)				(258)	(340)	(489)	(619)	(859)	(956)
CM112L	M_{max}	Nm					40.6	58.9	75.4	108.8	125.9
		(lb in)					(359)	(521)	(667)	(963)	(1114)
CM112H	M_{max}	Nm						58.4	75.3	111.1	131.1
		(lb in)						(517)	(666)	(983)	(1160)



Motor Selection

Motor selection for synchronous servomotors (SERVO)

Nominal speed $n_N = 4500$ rpm:

Motor			MOVIDRIVE® MDX61B...-2_3 (AC 230 V units) in the SERVO operating modes (P700)								
			0015	0022	0037	0055	0075	0110	0150	0220	0300
DS56M	M_{max}	Nm	3.8								
		(lb in)	(34)								
CM71S	M_{max}	Nm	6.4	7.5	12.1	16.3	16.5				
		(lb in)	(57)	(66)	(107)	(144)	(146)				
CM71M	M_{max}	Nm	6.3	7.4	12.2	17.4	21.0	21.4			
		(lb in)	(56)	(65)	(108)	(154)	(186)	(189)			
CM71L	M_{max}	Nm		7.2	12.1	17.9	22.8	29.9	31.3		
		(lb in)		(64)	(107)	(158)	(202)	(265)	(277)		
CM90S	M_{max}	Nm			12.6	19.0	24.8	34.4	39.6		
		(lb in)			(112)	(168)	(219)	(304)	(350)		
CM90M	M_{max}	Nm			12.1	18.3	24.1	34.3	42.8	52.0	
		(lb in)			(107)	(162)	(213)	(304)	(379)	(460)	
CM90L	M_{max}	Nm				17.7	23.4	33.7	42.9	61.4	70.5
		(lb in)				(157)	(207)	(298)	(380)	(543)	(624)
CM112S	M_{max}	Nm				20.0	26.5	38.2	48.6	68.3	77.7
		(lb in)				(177)	(235)	(338)	(430)	(605)	(688)
CM112M	M_{max}	Nm					24.8	36.1	46.3	67.4	78.5
		(lb in)					(219)	(320)	(410)	(597)	(695)

Nominal speed $n_N = 6000$ rpm:

Motor			MOVIDRIVE® MDX61B...-2_3 (AC 230 V units) in the SERVO operating modes (P700)								
			0015	0022	0037	0055	0075	0110	0150	0220	0300
CM71S	M_{max}	Nm	4.7	5.6	9.2	13.2	15.9	16.6			
		(lb in)	(42)	(50)	(81)	(117)	(141)	(147)			
CM71M	M_{max}	Nm	5.0	5.9	9.9	14.6	18.2	21.4			
		(lb in)	(44)	(52)	(88)	(129)	(161)	(189)			
CM71L	M_{max}	Nm			9.6	14.5	18.7	25.6	30.3	31.4	
		(lb in)			(85)	(128)	(166)	(227)	(268)	(278)	
CM90S	M_{max}	Nm			10.2	15.4	20.1	28.5	35.3	39.4	
		(lb in)			(90)	(136)	(178)	(252)	(312)	(349)	
CM90M	M_{max}	Nm				12.9	17.0	24.5	31.2	44.3	50.6
		(lb in)				(114)	(150)	(217)	(276)	(392)	(448)
CM90L	M_{max}	Nm					17.9	25.9	33.1	48.3	56.5
		(lb in)					(158)	(229)	(293)	(427)	(500)



8.4.6 Motor table CMD

Characteristic values at $U_{max} = AC 400 V$

n_N rpm	Motor	M_0 Nm (lb in)	I_0 A	I_{max} A	Mass moment of inertia J_M 10^{-4} kgm^2
1200	CMD93S	2.4 (21)	1.55	8.1	1.23
	CMD93M	4.2 (37)	2.5	16.2	2.31
	CMD93L	6.0 (50)	3.5	22.9	3.38
	CMD138S	6.7 (59)	3.9	13.2	6.4
	CMD138M	12.1 (107)	5.5	25.5	11.4
	CMD138L	16.5 (146)	8	40.2	16.5
2000	CMD138S	6.7 (59)	7.4	25.0	6.5
	CMD138M	12.1 (107)	11.4	53.0	11.4
	CMD138L	16.5 (146)	15.1	76.0	16.5
3000	CMD70S	0.7 (6)	1.04	5.8	0.261
	CMD70M	1.1 (9.7)	1.36	7.9	0.45
	CMD70L	1.9 (17)	1.96	17.7	0.83
	CMD93S	2.4 (21)	2.32	12.2	1.23
	CMD93M	4.2 (37)	3.6	23.2	2.31
	CMD93L	6.0 (53)	6	39.7	3.38
4500	CMD55S	0.25 (2.2)	0.7	4.1	0.087
	CMD55M	0.45 (4)	0.95	6.1	0.15
	CMD55L	0.9 (8)	1.5	12.2	0.267

8.4.7 CMD motor selection (line AC 400 V)

1. Nominal speed $n_N = 1200 \text{ rpm}$:

Motor		MOVIDRIVE® MDX61B....5_3 (AC 400 V units) in the SERVO operating modes (P700)											
		0005	0008	0011	0014	0015	0022	0030	0040	0055	0075	0110	0150
CMD93S	M_{max} Nm (lb in)	5.8 (51)	6.7 (59)	8.1 (72)	10 (89)	7.9 (70)	10 (89)						
CMD93M	M_{max} Nm (lb in)		8.2 (73)	10.5 (93)	13.3 (118)	10.2 (90)	13.6 (120)	16.6 (147)	20.6 (182)	22 (190)			
CMD93L	M_{max} Nm (lb in)			10.5 (93)	13.5 (119)	10.1 (89)	14.0 (124)	17.6 (156)	23.1 (204)	28.6 (253)	33 (290)		
CMD138S	M_{max} Nm (lb in)				12.5 (111)	9.8 (87)	12.8 (113)	15.2 (135)	17 (150)				
CMD138M	M_{max} Nm (lb in)							21.9 (194)	27.9 (247)	33.3 (295)	37.8 (335)	39 (350)	
CMD138L	M_{max} Nm (lb in)									36.8 (326)	45.0 (398)	59 (520)	62 (550)

2. Nominal speed $n_N = 2000 \text{ rpm}$:

Motor		MOVIDRIVE® MDX61B....5_3 (AC 400 V units) in the SERVO operating modes (P700)						
		0040	0055	0075	0110	0150	0220	0300
CMD138S	M_{max} Nm (lb in)	11.9 (105)	14.7 (130)	17 (150)				
CMD138M	M_{max} Nm (lb in)			23.7 (210)	31.8 (281)	37.2 (329)	38.8 (343)	
CMD138L	M_{max} Nm (lb in)				37.4 (331)	47.1 (417)	59.6 (528)	62 (550)



Motor Selection

Motor selection for synchronous servomotors (SERVO)

3. Nominal speed $n_N = 3000$ rpm:

Motor			MOVIDRIVE® MDX61B...-5_3 (AC 400 V units) in the SERVO operating modes (P700)											
			0005	0008	0011	0014	0015	0022	0030	0040	0055	0075	0110	0150
CMD70S	M_{max}	Nm (lb in)	2.2 (19)	2.5 (22)	3 (27)									
CMD70M	M_{max}	Nm (lb in)	3.2 (28)	3.7 (33)	4.5 (40)	5.2 (46)	4.4 (39)	5 (44)						
CMD70L	M_{max}	Nm (lb in)	3.8 (34)	4.5 (40)	5.8 (51)	7.4 (65)	5.7 (50)	7.6 (67)	9.1 (81)	10.6 (94)	11 (97)			
CMD93S	M_{max}	Nm (lb in)		4.8 (42)	6.0 (53)	7.3 (65)	5.8 (51)	7.5 (66)	8.8 (78)	10 (86)				
CMD93M	M_{max}	Nm (lb in)				9.5 (84)	7.2 (64)	9.8 (87)	12.3 (109)	15.9 (141)	19.5 (173)	22 (190)		
CMD93L	M_{max}	Nm (lb in)								13.9 (123)	18.1 (160)	22.5 (199)	30.7 (272)	33 (290)

4. Nominal speed $n_N = 4500$ rpm:

Motor			MOVIDRIVE® MDX61B...-5_3 (AC 400 V units) in the SERVO operating modes (P700)									
			0005	0008	0011	0014	0015	0022	0030	0040		
CMD55S	M_{max}	Nm (lb in)	1.2 (11)									
CMD55M	M_{max}	Nm (lb in)	1.8 (16)	2 (18)	2.3 (20)							
CMD55L	M_{max}	Nm (lb in)	2.5 (22)	2.9 (26)	3.7 (33)	4.5 (40)	3.6 (32)	4.6 (41)	5.4 (48)	6 (53)		



8.4.8 CMP motor table

Characteristic values at $U_{max} = AC 230 V / AC 400 V$

n_N rpm	Motor	Without forced cooling fan			With forced cooling fan VR			$I_{max}^{1)}$ A	$I_{max}^{2)}$ A	Mass moment of inertia J_M without brake with brake 10^{-4} kgm^2	
		M_0 Nm (lb in)	$I_0^{1)}$ A	$I_0^{2)}$ A	M_{0_VR} Nm (lb in)	$I_{0_VR}^{1)}$ A	$I_{0_VR}^{2)}$ A				
2000	CMP71S	6.4 (57)	3.4	-	8.7 (77)	4.6	-	17	-	3.01	3.45
	CMP71M	9.4 (83)	5	-	13.7 (121)	7.3	-	26	-	4.06	4.5
	CMP71L	13.1 (116)	6.3	-	21 (186)	10.1	-	39	-	6.16	6.6
	CMP80S	13.4 (119)	6.9	-	18.5 (164)	9.5	-	33	-	8.39	9.79
	CMP80M	18.7 (166)	9.3	-	27 (239)	13.4	-	48	-	11.5	12.9
	CMP80L	27.5 (243)	12.4	-	44 (389)	20	-	72	-	17.7	19.1
	CMP100S	25.5 (225)	13.3	-	36 (319)	18.8	-	49	-	19.3	22.2
	CMP100M	31 (274)	14.9	-	47 (416)	22.3	-	69	-	26.3	29.1
CMP100L	47 (416)	21.8	-	70 (620)	32.5	-	113	-	40	42.8	
3000	CMP40S	0.5 (4)	1.2	1.2	-	-	-	6.1	6.1	0.104	0.132
	CMP40M	0.8 (7)	0.95	1.1	-	-	-	6.0	6.9	0.148	0.176
	CMP50S	1.3 (12)	0.96	1.64	1.7 (15)	1.25	-	5.1	9.8	0.415	0.481
	CMP50M	2.4 (21)	1.68	2.84	3.5 (31)	2.45	-	9.6	17.1	0.667	0.733
	CMP50L	3.3 (29)	2.2	3.84	4.8 (42)	3.2	-	13.6	23.1	0.919	0.985
	CMP63S	2.9 (26)	2.15	3.61	4 (35)	3	-	12.9	21.7	1.15	1.49
	CMP63M	5.3 (47)	3.6	6.35	7.5 (66)	5.1	-	21.6	38.1	1.92	2.26
	CMP63L	7.1 (63)	4.95	8.76	10.3 (91)	7.2	-	29.7	52.6	2.69	3.03
	CMP71S	6.4 (57)	4.9	8.7	8.7 (77)	6.7	11.8	25	44	3.01	3.45
	CMP71M	9.4 (83)	7.5	13.1	13.7 (121)	10.9	19.1	39	68	4.06	4.5
	CMP71L	13.1 (116)	9.4	16.8	21 (186)	15.1	27	58	103	6.16	6.6
	CMP80S	13.4 (119)	10	17.7	18.5 (164)	13.8	24.5	47	83	8.39	9.79
	CMP80M	18.7 (166)	13.4	23.5	27 (239)	19.3	34	69	121	11.5	12.9
	CMP80L	27.5 (243)	18.7	32.5	44 (389)	30	52	107	186	17.7	19.1
	CMP100S	25.5 (225)	19.6	34.2	36 (319)	27.5	-	73	127	19.3	22.2
	CMP100M	31 (274)	21.8	40	47 (416)	33	-	102	187	26.3	29.1
CMP100L	47 (416)	32.3	58.1	70 (620)	48	-	167	-	40	42.8	
4500	CMP40S	0.5 (4)	1.2	1.2	-	-	-	6.1	6.1	0.104	0.132
	CMP40M	0.8 (7)	0.95	1.5	-	-	-	6	9	0.148	0.176
	CMP50S	1.3 (12)	1.32	2.29	1.7 (15)	1.7	-	7	13.8	0.415	0.481
	CMP50M	2.4 (21)	2.3	4.025	3.5 (31)	3.35	-	13.1	24.2	0.667	0.733
	CMP50L	3.3 (29)	3.15	5.53	4.8 (42)	4.6	-	19.5	33.2	0.919	0.985
	CMP63S	2.9 (26)	3.05	5.25	4 (35)	4.2	-	18.3	31.5	1.15	1.49
	CMP63M	5.3 (47)	5.4	9.78	7.5 (66)	7.6	-	32.4	58.7	1.92	2.26
	CMP63L	7.1 (63)	6.9	12.0	10.3 (91)	10	-	41.4	72.1	2.69	3.03
	CMP71S	6.4 (57)	7.3	12.8	8.7 (77)	9.9	17.4	38	67	3.01	3.45
	CMP71M	9.4 (83)	10.9	19.2	13.7 (121)	15.9	28	57	101	4.06	4.5
	CMP71L	13.1 (116)	14.1	25.6	21 (186)	22.5	-	87	-	6.16	6.6
	CMP80S	13.4 (119)	15.3	27	18.5 (164)	21	37	73	129	8.39	9.79
	CMP80M	18.7 (166)	20.1	35	27 (239)	29	51	103	180	11.5	12.9
	CMP80L	27.5 (243)	27.8	49.9	44 (389)	44.5	-	159	-	17.7	19.1
	CMP100S	25.5 (225)	29.9	54.5	36 (319)	42.5	-	111	200	19.3	22.2
	CMP100M	31 (274)	33.1	60	47 (416)	50	-	154	-	26.3	29.1
CMP100L	47 (416)	48.4	-	70 (620)	72	-	251	-	40	42.8	



Motor Selection

Motor selection for synchronous servomotors (SERVO)

n_N rpm	Motor	Without forced cooling fan			With forced cooling fan VR			$I_{max}^{1)}$ A	$I_{max}^{2)}$ A	Mass moment of inertia J_M		
		M_0 Nm (lb in)	$I_0^{1)}$ A	$I_0^{2)}$ A	M_{0_VR} Nm (lb in)	$I_{0_VR}^{1)}$ A	$I_{0_VR}^{2)}$ A			without brake	with brake	
											10^{-4} kgm^2	
6000	CMP40S	0.5 (4)	1.2	1.36	-	-	-	6.1	6.8	0.104	0.132	
	CMP40M	0.8 (7)	1.1	1.91	-	-	-	6.9	11.5	0.148	0.176	
	CMP50S	1.3 (12)	1.7	3.07	1.7 (15)	2.2	-	9	18.5	0.415	0.481	
	CMP50M	2.4 (21)	3	5.25	3.5 (31)	4.4	-	17.1	31.5	0.667	0.733	
	CMP50L	3.3 (29)	4.2	7.6	4.8 (42)	6.1	-	26	45.4	0.919	0.985	
	CMP63S	2.9 (26)	3.9	6.78	4 (35)	5.4	-	23.4	40.7	1.15	1.49	
	CMP63M	5.3 (47)	6.9	12.06	7.5 (66)	9.8	-	41.4	72.4	1.92	2.26	
	CMP63L	7.1 (63)	9.3		10.3 (91)	13.5	-	55.8	-	2.69	3.03	
	CMP71S	6.4 (57)	9.6	17	8.7 (77)	13.1	23	50	89	3.01	3.45	
	CMP71M	9.4 (83)	14.7	26.3	13.7 (121)	21.5	-	76	-	4.06	4.5	
	CMP71L	13.1 (116)	18.8		21 (186)	30	-	115	-	6.16	6.6	
	CMP80S	13.4 (119)	20	35.5	18.5 (164)	27.5	48.5	95	168	8.39	9.79	
	CMP80M	18.7 (166)	26.4	46.9	27 (239)	38	-	135		11.5	12.9	
	CMP80L	27.5 (243)	37.6	68	44 (389)	60	-	215	-	17.7	19.1	

1) For DS/CM synchronous servomotors with AC 400 V system voltage

2) For DS/CM synchronous servomotors with AC 230 V system voltage



8.4.9 CMP motor selection (line AC 400 V)

Nominal speed $n_N = 2000$ rpm:

Assignment of **MOVIDRIVE® MDX61B0005-5_3 - MDX61B0110-5_3** (sizes 0 - 2):

Motor			MOVIDRIVE® MDX61B...-5_3 (AC 400 V units) in SERVO operating modes (P700)										
			0005	0008	0011	0014	0015	0022	0030	0040	0055	0075	0110
CMP71S	M_{max}	Nm (lb in)	6.5 (58)	7.6 (67)	9.6 (85)	11.8 (104)	9.3 (82)	12.1 (107)	14.4 (127)	17.1 (151)	18.0 (159)		
CMP71M	M_{max}	Nm (lb in)			9.6 (85)	12.3 (109)	9.4 (83)	12.7 (112)	15.7 (139)	20.1 (178)	24.2 (214)	27.4 (243)	
CMP71L	M_{max}	Nm (lb in)				13.6 (120)	10.2 (90)	14.1 (125)	17.8 (158)	23.7 (210)	30.0 (266)	36.1 (320)	41.1 (364)
CMP80S	M_{max}	Nm (lb in)				12.7 (112)	9.5 (84)	13.2 (116)	16.9 (149)	22.7 (201)	28.7 (254)	34.0 (301)	39.3 (348)
CMP80M	M_{max}	Nm (lb in)						13.9 (123)	17.7 (157)	23.8 (211)	30.8 (273)	38.2 (337)	51.1 (452)
CMP80L	M_{max}	Nm (lb in)							19.3 (171)	26.1 (231)	34.0 (301)	43.0 (381)	61.7 (546)
CMP100S	M_{max}	Nm (lb in)							17.0 (150)	23.0 (204)	30.0 (266)	37.6 (333)	52.2 (462)
CMP100M	M_{max}	Nm (lb in)								24.7 (219)	32.5 (288)	41.5 (367)	60.7 (537)
CMP100L	M_{max}	Nm (lb in)									34.0 (301)	43.5 (385)	64.8 (574)

Assignment of **MOVIDRIVE® MDX61B0150-5_3 - MDX61B1320-5_3** (sizes 3 - 6):

Motor			MOVIDRIVE® MDX61B...-5_3 (AC 400 V units) in SERVO operating modes (P700)										
			0150	0220	0300	0370	0450	0550	0750	0900	1100	1320	
CMP80M	M_{max}	Nm (lb in)	57.0 (504)										
CMP80L	M_{max}	Nm (lb in)	77.5 (686)	89.4 (791)									
CMP100S	M_{max}	Nm (lb in)	62.2 (551)	68.1 (603)									
CMP100M	M_{max}	Nm (lb in)	77.2 (683)	98.1 (868)	100.0 (885)								
CMP100L	M_{max}	Nm (lb in)	85.1 (753)	116.6 (1032)	142.0 (1257)	155.9 (1380)							



Motor Selection

Motor selection for synchronous servomotors (SERVO)

Nominal speed $n_N = 3000$ rpm:

Assignment of **MOVIDRIVE® MDX61B0005-5_3 - MDX61B0110-5_3** (sizes 0 - 2):

Motor			MOVIDRIVE® MDX61B...-5_3 (AC 400 V units) in SERVO operating modes (P700)														
			0005	0008	0011	0014	0015	0022	0030	0040	0055	0075	0110				
CMP40S	M_{max}	Nm (lb in)	1.5 (13)	1.9 (17)			1.9 (17)										
CMP40M	M_{max}	Nm (lb in)	3.0 (27)	3.4 (30)	3.8 (34)		3.8 (3.4)										
CMP50S	M_{max}	Nm (lb in)	4.5 (40)	5.0 (44)	5.2 (46)		5.2 (46)										
CMP50M	M_{max}	Nm (lb in)	5.4 (48)	6.3 (56)	7.7 (68)	9.3 (82)	7.6 (67)	9.4 (83)	10.3 (91)								
CMP50L	M_{max}	Nm (lb in)	5.9 (52)	7.0 (62)	8.8 (78)	10.8 (95)	8.5 (75)	11.1 (98)	13.2 (117)	15.4 (136)							
CMP63S	M_{max}	Nm (lb in)	5.2 (46)	6.0 (53)	7.2 (64)	8.6 (76)	7.1 (63)	8.8 (78)	10.1 (89)	11.1 (98)							
CMP63M	M_{max}	Nm (lb in)	6.1 (54)	7.1 (63)	9.0 (80)	11.1 (98)	8.7 (77)	11.4 (101)	13.8 (122)	17.0 (150)	20.0 (177)	21.4 (189)					
CMP63L	M_{max}	Nm (lb in)			9.0 (80)	11.4 (101)	8.7 (77)	11.7 (103)	14.5 (127)	18.7 (166)	23.0 (204)	27.1 (240)	30.4 (269)				
CMP71S	M_{max}	Nm (lb in)			6.9 (61)	8.6 (76)	6.7 (59)	8.9 (79)	10.9 (96)	13.8 (122)	16.3 (144)	18.0 (159)					
CMP71M	M_{max}	Nm (lb in)				8.4 (74)	6.4 (57)	8.7 (77)	10.9 (96)	14.5 (128)	18.3 (162)	22 (195)	27.5 (243)				
CMP71L	M_{max}	Nm (lb in)						9.5 (84)	12.1 (107)	16.3 (144)	21.2 (187)	26.5 (235)	36.3 (321)				
CMP80S	M_{max}	Nm (lb in)						8.9 (79)	11.5 (102)	15.7 (139)	20.6 (182)	25.8 (228)	34.6 (306)				
CMP80M	M_{max}	Nm (lb in)							12.3 (109)	16.6 (148)	21.8 (193)	27.6 (244)	39.4 (349)				
CMP80L	M_{max}	Nm (lb in)								17.3 (153)	22.7 (201)	28.9 (256)	42.6 (377)				
CMP100S	M_{max}	Nm (lb in)									20.5 (181)	26.2 (232)	38.2 (338)				
CMP100M	M_{max}	Nm (lb in)									22.2 (196)	28.5 (252)	42.5 (377)				
CMP100L	M_{max}	Nm (lb in)											44.0 (389)				



Assignment of **MOVIDRIVE® MDX61B0150-5_3 - MDX61B1320-5_3** (sizes 3 - 6):

Motor			MOVIDRIVE® MDX61B...-5_3 (AC 400 V units) in SERVO operating modes (P700)									
			0150	0220	0300	0370	0450	0550	0750	0900	1100	1320
CMP71L	M_{max}	Nm (lb in)	41.1 (364)									
CMP80S	M_{max}	Nm (lb in)	39.3 (348)									
CMP80M	M_{max}	Nm (lb in)	48.8 (432)	57.0 (504)								
CMP80L	M_{max}	Nm (lb in)	55.4 (490)	74.6 (660)	89.3 (790)							
CMP100S	M_{max}	Nm (lb in)	48.5 (429)	61.4 (543)	68.3 (605)							
CMP100M	M_{max}	Nm (lb in)	56.0 (496)	76.3 (675)	92.0 (814)	100.2 (887)						
CMP100L	M_{max}	Nm (lb in)	58.5 (518)	82.7 (732)	104.9 (928)	123.1 (1090)	142.1 (1257)	155.9 (1380)				



Motor Selection

Motor selection for synchronous servomotors (SERVO)

Nominal speed $n_N = 4500$ rpm:

Assignment of **MOVIDRIVE® MDX61B0005-5_3 - MDX61B0110-5_3** (sizes 0 - 2):

Motor			MOVIDRIVE® MDX61B...-5_3 (AC 400 V units) in SERVO operating modes (P700)										
			0005	0008	0011	0014	0015	0022	0030	0040	0055	0075	0110
CMP40S	M_{max}	Nm (lb in)	1.5 (13)	1.7 (15)	1.9 (17)		1.9 (17)	1.9 (17)					
CMP40M	M_{max}	Nm (lb in)	3.0 (27)	3.4 (30)	3.8 (34)		3.8 (34)						
CMP50S	M_{max}	Nm (lb in)	3.5 (31)	4.1 (36)	4.8 (42)	5.2 (46)	4.7 (42)	5.2 (46)					
CMP50M	M_{max}	Nm (lb in)	4.2 (36)	4.8 (42)	6.1 (53)	7.4 (65)	5.9 (52)	7.6 (67)	9.0 (80)	10.3 (91)			
CMP50L	M_{max}	Nm (lb in)	4.2 (37)	5.0 (44)	6.3 (56)	7.9 (70)	6.1 (54)	8.2 (73)	10.0 (89)	12.7 (112)	15.1 (134)	15.4 (136)	
CMP63S	M_{max}	Nm (lb in)	3.8 (34)	4.5 (40)	5.6 (50)	6.8 (60)	5.4 (48)	6.9 (61)	8.2 (73)	9.9 (88)	11.1 (98)		
CMP63M	M_{max}	Nm (lb in)			6.3 (56)	7.9 (70)	6.1 (54)	8.1 (72)	10.0 (89)	12.8 (113)	15.7 (139)	18.3 (162)	21.4 (189)
CMP63L	M_{max}	Nm (lb in)				8.3 (73)	6.3 (56)	8.6 (76)	10.7 (95)	14.0 (124)	17.7 (157)	21.5 (190)	28.2 (250)
CMP71S	M_{max}	Nm (lb in)				6.0 (53)	4.6 (41)	6.2 (55)	7.7 (68)	10.1 (89)	12.5 (111)	14.9 (132)	17.9 (158)
CMP71M	M_{max}	Nm (lb in)						6.0 (53)	7.6 (67)	10.2 (90)	13.1 (116)	16.4 (145)	22.4 (198)
CMP71L	M_{max}	Nm (lb in)								10.9 (96)	14.4 (127)	18.3 (162)	26.5 (235)
CMP80S	M_{max}	Nm (lb in)								10.1 (89)	13.4 (119)	17.3 (153)	25.3 (224)
CMP80M	M_{max}	Nm (lb in)									14.6 (129)	18.6 (165)	27.6 (244)
CMP80L	M_{max}	Nm (lb in)										19.6 (173)	29.2 (258)
CMP100S	M_{max}	Nm (lb in)										17.2 (152)	25.7 (227)
CMP100M	M_{max}	Nm (lb in)											28.2 (250)

Assignment of **MOVIDRIVE® MDX61B0150-5_3 - MDX61B1320-5_3** (sizes 3 - 6):

Motor			MOVIDRIVE® MDX61B...-5_3 (AC 400 V units) in SERVO operating modes (P700)										
			0150	0220	0300	0370	0450	0550	0750	0900	1100	1320	
CMP63L	M_{max}	Nm (lb in)	30.4 (269)										
CMP71S	M_{max}	Nm (lb in)											
CMP71M	M_{max}	Nm (lb in)	26.4 (234)	27.4 (243)									
CMP71L	M_{max}	Nm (lb in)	33.3 (295)	41.1 (364)									
CMP80S	M_{max}	Nm (lb in)	31.7 (281)	38.3 (339)	39.2 (347)								
CMP80M	M_{max}	Nm (lb in)	35.7 (316)	47.3 (419)	55.2 (489)	56.9 (504)							
CMP80L	M_{max}	Nm (lb in)	38.5 (341)	53.8 (476)	67.4 (597)	78.3 (693)	89.3 (790)						
CMP100S	M_{max}	Nm (lb in)	33.8 (299)	46.3 (410)	56.1 (497)	62.6 (554)	68.3 (605)						
CMP100M	M_{max}	Nm (lb in)	37.6 (333)	53.3 (472)	67.5 (597)	79.0 (699)	90.7 (803)	99.8 (883)	100.2 (887)				



Motor			MOVIDRIVE® MDX61B...-5_3 (AC 400 V units) in SERVO operating modes (P700)									
			0150	0220	0300	0370	0450	0550	0750	0900	1100	1320
CMP100L	M _{max}	Nm	39.1	56.1	72.6	87.1	103.9	119.2	139.6	155.8		
		(lb in)	(346)	(497)	(643)	(771)	(920)	(1055)	(1236)	(1379)		

Nominal speed $n_N = 6000$ rpm:

Assignment of MOVIDRIVE® MDX61B0005-5_3 - MDX61B0110-5_3 (sizes 0 - 2):

Motor			MOVIDRIVE® MDX61B...-5_3 (AC 400 V units) in SERVO operating modes (P700)										
			0005	0008	0011	0014	0015	0022	0030	0040	0055	0075	0110
CMP40S	M _{max}	Nm	1.5	1.7	1.9		1.9	1.9					
		(lb in)	(13)	(15)	(17)		(17)	(17)					
CMP40M	M _{max}	Nm	2.6	3.0	3.6	3.8	3.5	3.8					
		(lb in)	(23)	(27)	(32)	(34)	(31)	(34)					
CMP50S	M _{max}	Nm	2.9	3.3	4.1	4.8	4.0	4.9	5.2				
		(lb in)	(26)	(29)	(36)	(42)	(35)	(43)	(46)				
CMP50M	M _{max}	Nm	3.2	3.8	4.8	6.0	4.6	6.1	7.4	9.2	10.3		
		(lb in)	(28)	(34)	(42)	(54)	(41)	(54)	(65)	(81)	(91)		
CMP50L	M _{max}	Nm		3.8	4.8	6.1	4.7	6.3	7.8	10.2	12.5	14.7	15.4
		(lb in)		(34)	(42)	(54)	(42)	(56)	(69)	(90)	(111)	(130)	(136)
CMP63S	M _{max}	Nm	3.1	3.6	4.5	5.6	4.4	5.8	6.9	8.6	10.0	11.1	
		(lb in)	(27)	(32)	(40)	(50)	(39)	(51)	(61)	(76)	(89)	(98)	
CMP63M	M _{max}	Nm				6.3	4.8	6.5	8.0	10.4	13.0	15.6	20.0
		(lb in)				(56)	(42)	(58)	(71)	(92)	(115)	(138)	(177)
CMP63L	M _{max}	Nm						6.5	8.1	10.8	13.8	17.0	23.3
		(lb in)						(58)	(72)	(96)	(122)	(150)	(206)
CMP71S	M _{max}	Nm						4.8	6.0	8.0	10.1	12.3	16.1
		(lb in)						(42)	(53)	(71)	(89)	(109)	(143)
CMP71M	M _{max}	Nm								7.7	10.0	12.6	18.0
		(lb in)								(68)	(89)	(112)	(159)
CMP71L	M _{max}	Nm								8.2	10.8	13.8	20.4
		(lb in)								(73)	(96)	(122)	(181)
CMP80S	M _{max}	Nm								10.2	13.2	19.8	
		(lb in)								(90)	(117)	(175)	
CMP80M	M _{max}	Nm									14.2	21.3	
		(lb in)									(126)	(189)	
CMP80L	M _{max}	Nm										21.8	
		(lb in)											(193)

Assignment of MOVIDRIVE® MDX61B0150-5_3 - MDX61B1320-5_3 (sizes 3 - 6):

Motor			MOVIDRIVE® MDX61B...-5_3 (AC 400 V units) in SERVO operating modes (P700)										
			0150	0220	0300	0370	0450	0550	0750	0900	1100	1320	
CMP63M	M _{max}	Nm	21.4										
		(lb in)	(189)										
CMP63L	M _{max}	Nm	28.1	30.4									
		(lb in)	(249)	(269)									
CMP71S	M _{max}	Nm	18.0										
		(lb in)	(159)										
CMP71M	M _{max}	Nm	22.3	27.3	27.5								
		(lb in)	(196)	(242)	(243)								
CMP71L	M _{max}	Nm	26.5	35.3	41.2	41.2							
		(lb in)	(235)	(312)	(365)	(365)							
CMP80S	M _{max}	Nm	25.8	33.7	38.3	39.2							
		(lb in)	(228)	(298)	(339)	(347)							
CMP80M	M _{max}	Nm	28.9	38.5	47.1	53.1	57.0						
		(lb in)	(256)	(341)	(417)	(470)	(504)						
CMP80L	M _{max}	Nm	28.9	41.0	52.3	62.0	72.8	61.9	82.1	89.5			
		(lb in)	(256)	(363)	(463)	(549)	(644)	(548)	(727)	(792)			



Motor Selection

Motor selection for synchronous servomotors (SERVO)

8.4.10 CMP motor selection (line AC 230 V)

Nominal speed $n_N = 3000$ rpm:

Motor			MOVIDRIVE® MDX61B...._2_3 (AC 230 V units) in the SERVO operating modes (P700)									
			0015	0022	0037	0055	0075	0110	0150	0220	0300	
CMP40S	M_{max}	Nm (lb in)	1.9 (16.8)									
CMP40M	M_{max}	Nm (lb in)	3.8 (33.7)									
CMP50S	M_{max}	Nm (lb in)	5.2 (46.1)									
CMP50M	M_{max}	Nm (lb in)	8.0 (71.1)	9.0 (79.8)	10.3 (91.2)							
CMP50L	M_{max}	Nm (lb in)	8.8 (77.7)	10.1 (89.5)	14.6 (129)	15.4 (136)						
CMP63S	M_{max}	Nm (lb in)	7.5 (66.8)	8.4 (74.7)	11.1 (98.3)							
CMP63M	M_{max}	Nm (lb in)	9.0 (79.7)	10.3 (91.2)	15.5 (137)	20.0 (177)	21.4 (190)					
CMP63L	M_{max}	Nm (lb in)	8.9 (78.9)	10.4 (92.1)	16.4 (145)	22.8 (202)	27.4 (243)	30.3 (268)	30.4 (269)			
CMP71S	M_{max}	Nm (lb in)	6.9 (61.2)	8.0 (71.0)	12.3 (109)	16.2 (143)	18.0 (159)					
CMP71M	M_{max}	Nm (lb in)	6.6 (58.4)	7.8 (68.6)	12.8 (113)	18.4 (163)	22.5 (199)	27.5 (243)				
CMP71L	M_{max}	Nm (lb in)		8.3 (73.5)	14.0 (124)	21.0 (186)	26.9 (238)	35.9 (316)	41.3 (366)			
CMP80S	M_{max}	Nm (lb in)			13.5 (119)	20.5 (181)	26.3 (233)	34.4 (305)	38.6 (342)	39.2 (347)		
CMP80M	M_{max}	Nm (lb in)			14.5 (128)	21.9 (194)	28.5 (252)	39.4 (349)	47.5 (421)	57.0 (505)		
CMP80L	M_{max}	Nm (lb in)				23.0 (204)	30.1 (266)	42.9 (380)	53.9 (477)	74.6 (660)	84.3 (746)	



Nominal speed $n_N = 4500$ rpm:

Motor			MOVIDRIVE® MDX61B....-2_3 (AC 230 V units) in the SERVO operating modes (P700)								
			0015	0022	0037	0055	0075	0110	0150	0220	0300
CMP40S	M_{max}	Nm (lb in)	1.9 (16.8)								
CMP40M	M_{max}	Nm (lb in)	3.8 (33.6)								
CMP50S	M_{max}	Nm (lb in)	4.9 (43.4)	5.3 (46.9)	5.2 (46.0)						
CMP50M	M_{max}	Nm (lb in)	6.1 (54.0)	7.0 (62.0)	10.0 (88.5)	10.3 (91.2)					
CMP50L	M_{max}	Nm (lb in)	6.3 (55.8)	7.4 (65.5)	11.4 (100.9)	15.1 (133.6)	15.4 (136.3)				
CMP63S	M_{max}	Nm (lb in)	5.7 (50.4)	6.5 (57.5)	9.2 (81.4)	11.1 (98.2)					
CMP63M	M_{max}	Nm (lb in)	6.1 (54.0)	7.1 (62.8)	11.2 (99.1)	15.4 (136.3)	18.4 (162.9)	21.4 (189.4)			
CMP63L	M_{max}	Nm (lb in)	6.6 (58.4)	7.7 (68.2)	12.5 (110.6)	17.9 (158.4)	22.2 (196.5)	28.3 (250.5)	30.4 (269.1)		
CMP71S	M_{max}	Nm (lb in)	4.7 (41.6)	5.5 (48.7)	8.9 (78.8)	12.5 (110.6)	15.2 (134.5)	17.9 (158.4)			
CMP71M	M_{max}	Nm (lb in)			8.9 (78.8)	13.1 (115.9)	16.7 (147.8)	22.3 (197.4)	25.8 (228.3)	27.4 (242.5)	
CMP80S	M_{max}	Nm (lb in)			8.7 (77.0)	13.4 (118.6)	17.7 (156.7)	25.1 (222.2)	30.7 (271.7)	38.1 (337.2)	39.2 (346.9)
CMP80M	M_{max}	Nm (lb in)				14.7 (130.1)	19.3 (170.8)	27.6 (244.3)	34.6 (306.2)	47.1 (416.9)	52.4 (463.8)

Nominal speed $n_N = 6000$ rpm:

Motor			MOVIDRIVE® MDX61B....-2_3 (AC 230 V units) in the SERVO operating modes (P700)								
			0015	0022	0037	0055	0075	0110	0150	0220	0300
CMP40S	M_{max}	Nm (lb in)	1.9 (16.8)								
CMP40M	M_{max}	Nm (lb in)	3.6 (31.9)	3.8 (33.6)							
CMP50S	M_{max}	Nm (lb in)	4.0 (35.4)	4.5 (39.8)	5.2 (46.0)						
CMP50M	M_{max}	Nm (lb in)	4.8 (42.5)	5.6 (49.6)	8.5 (75.2)	10.3 (91.2)					
CMP50L	M_{max}	Nm (lb in)	4.7 (41.6)	5.5 (48.7)	8.8 (77.9)	12.3 (108.9)	14.8 (131.0)	15.4 (136.3)			
CMP63S	M_{max}	Nm (lb in)	4.6 (40.7)	5.3 (46.9)	7.8 (69.0)	10.1 (89.4)	11.1 (98.2)				
CMP63M	M_{max}	Nm (lb in)	5.0 (44.3)	5.9 (52.2)	9.4 (83.2)	13.1 (115.9)	16.1 (142.5)	20.1 (177.9)	21.4 (189.4)		
CMP71S	M_{max}	Nm (lb in)		4.3 (38.1)	7.0 (62.0)	10.1 (89.4)	12.5 (110.6)	16.0 (141.6)	17.9 (158.4)	18.0 (159.3)	
CMP80S	M_{max}	Nm (lb in)				10.1 (89.4)	13.5 (119.5)	19.6 (173.5)	24.7 (218.6)	33.4 (295.6)	36.6 (323.9)



9 Address Directory

Germany				
Headquarters Production Sales	Bruchsal	SEW-EURODRIVE GmbH & Co KG Ernst-Blickle-Straße 42 D-76646 Bruchsal P.O. Box Postfach 3023 • D-76642 Bruchsal	Tel. +49 7251 75-0 Fax +49 7251 75-1970 http://www.sew-eurodrive.de sew@sew-eurodrive.de	
	Production / Industrial Gears	Bruchsal	SEW-EURODRIVE GmbH & Co KG Christian-Pähr-Str. 10 D-76646 Bruchsal	Tel. +49 7251 75-0 Fax +49 7251 75-2970
Production	Graben	SEW-EURODRIVE GmbH & Co KG Ernst-Blickle-Straße 1 D-76676 Graben-Neudorf P.O. Box Postfach 1220 • D-76671 Graben-Neudorf	Tel. +49 7251 75-0 Fax +49 7251 75-2970	
	Östringen	SEW-EURODRIVE Östringen GmbH Franz-Gurk-Straße 2 D-76684 Östringen P.O. Box Postfach 1174 • D-76677 Östringen	Tel. +49 7253 92540 Fax +49 7253 925490 oesstringen@sew-eurodrive.de	
Service Competence Center	Central	SEW-EURODRIVE GmbH & Co KG Ernst-Blickle-Straße 1 D-76676 Graben-Neudorf	Tel. +49 7251 75-1710 Fax +49 7251 75-1711 sc-mitte@sew-eurodrive.de	
	North	SEW-EURODRIVE GmbH & Co KG Alte Ricklinger Straße 40-42 D-30823 Garbsen (near Hannover)	Tel. +49 5137 8798-30 Fax +49 5137 8798-55 sc-nord@sew-eurodrive.de	
	East	SEW-EURODRIVE GmbH & Co KG Dänkritzter Weg 1 D-08393 Meerane (near Zwickau)	Tel. +49 3764 7606-0 Fax +49 3764 7606-30 sc-ost@sew-eurodrive.de	
	South	SEW-EURODRIVE GmbH & Co KG Domagkstraße 5 D-85551 Kirchheim (near München)	Tel. +49 89 909552-10 Fax +49 89 909552-50 sc-sued@sew-eurodrive.de	
	West	SEW-EURODRIVE GmbH & Co KG Siemensstraße 1 D-40764 Langenfeld (near Düsseldorf)	Tel. +49 2173 8507-30 Fax +49 2173 8507-55 sc-west@sew-eurodrive.de	
	Electronics	SEW-EURODRIVE GmbH & Co KG Ernst-Blickle-Straße 42 D-76646 Bruchsal	Tel. +49 7251 75-1780 Fax +49 7251 75-1769 sc-elektronik@sew-eurodrive.de	
	Drive Service Hotline / 24 Hour Service		+49 180 5 SEWHELP +49 180 5 7394357	
	Technical Offices	Augsburg	SEW-EURODRIVE GmbH & Co KG August-Wessels-Straße 27 D-86156 Augsburg	Tel. +49 821 22779-10 Fax +49 821 22779-50 tb-augsburg@sew-eurodrive.de
Berlin		SEW-EURODRIVE GmbH & Co KG Lilienthalstraße 3a D-12529 Schönefeld	Tel. +49 306331131-30 Fax +49 306331131-36 tb-berlin@sew-eurodrive.de	
Bodensee		SEW-EURODRIVE GmbH & Co KG Burgbergring 91 D-88662 Überlingen	Tel. +49 7551 9226-30 Fax +49 7551 9226-56 tb-bodensee@sew-eurodrive.de	
Bremen		SEW-EURODRIVE GmbH & Co KG Bornstr.19 ... 22 D-28195 Bremen	Tel. +49 421 33918-10 Fax +49 421 33918-22 tb-bremen@sew-eurodrive.de	
Dortmund		SEW-EURODRIVE GmbH & Co KG Hildastraße 10 D-44145 Dortmund	Tel. +49 231 912050-10 Fax +49 231 912050-20 tb-dortmund@sew-eurodrive.de	



Germany			
Dresden	SEW-EURODRIVE GmbH & Co KG Hauptstraße 32 D-01445 Radebeul	Tel. +49 351 26338-0 Fax +49 351 26338-38 tb-dresden@sew-eurodrive.de	
Erfurt	SEW-EURODRIVE GmbH & Co KG Dubliner Straße 12 D-99091 Erfurt	Tel. +49 361 21709-70 Fax +49 361 21709-79 tb-erfurt@sew-eurodrive.de	
Güstrow	SEW-EURODRIVE GmbH & Co KG Am Gewerbegrund 3 D-18273 Güstrow P.O. Box Postfach 1216 • D-18262 Güstrow	Tel. +49 3843 8557-80 Fax +49 3843 8557-88 tb-guestrow@sew-eurodrive.de	
Hamburg	SEW-EURODRIVE GmbH & Co KG Bramfelder Straße 119 D-22305 Hamburg	Tel. +49 40 298109-60 Fax +49 40 298109-70 tb-hamburg@sew-eurodrive.de	
Hannover/Garbsen	SEW-EURODRIVE GmbH & Co KG Alte Ricklinger Str.40-42 D-30823 Garbsen P.O. Box Postfach 1104 53 • D-30804 Garbsen	Tel. +49 5137 8798-10 Fax +49 5137 8798-50 tb-hannover@sew-eurodrive.de	
Heilbronn	SEW-EURODRIVE GmbH & Co KG Zeppelinstraße 7 D-74357 Bönnigheim	Tel. +49 7143 8738-0 Fax +49 7143 8738-25 tb-heilbronn@sew-eurodrive.de	
Herford	SEW-EURODRIVE GmbH & Co KG Radewiger Straße 21 D-32052 Herford P.O. Box Postfach 4108 • D-32025 Herford	Tel. +49 5221 9141-0 Fax +49 5221 9141-20 tb-herford@sew-eurodrive.de	
Karlsruhe	SEW-EURODRIVE GmbH & Co KG Ettlinger Weg 2 D-76467 Bietigheim P.O. Box Postfach 43 • D-76463 Bietigheim	Tel. +49 7245 9190-10 Fax +49 7245 9190-20 tb-karlsruhe@sew-eurodrive.de	
Kassel	SEW-EURODRIVE GmbH & Co KG Lange Straße 14 D-34253 Lohfelden	Tel. +49 561 95144-80 Fax +49 561 95144-90 tb-kassel@sew-eurodrive.de	
Koblenz	SEW-EURODRIVE GmbH & Co KG Bahnstraße 17a D-56743 Mendig	Tel. +49 2652 9713-30 Fax +49 2652 9713-40 tb-koblenz@sew-eurodrive.de	
Lahr	SEW-EURODRIVE GmbH & Co KG Europastraße 3/1 D-77933 Lahr / Schwarzwald	Tel. +49 7821 90999-60 Fax +49 7821 90999-79 tb-lahr@sew-eurodrive.de	
Langenfeld	SEW-EURODRIVE GmbH & Co KG Siemensstraße 1 D-40764 Langenfeld	Tel. +49 2173 8507-10 Fax +49 2173 8507-50 tb-langenfeld@sew-eurodrive.de	
Magdeburg	SEW-EURODRIVE GmbH & Co KG Breiteweg 53 D-39179 Barleben	Tel. +49 39203 7577-1 Fax +49 39203 7577-9 tb-magdeburg@sew-eurodrive.de	
Mannheim	SEW-EURODRIVE GmbH & Co KG Besselstraße 26 D-68219 Mannheim	Tel. +49 621 71683-10 Fax +49 621 71683-22 tb-mannheim@sew-eurodrive.de	
München	SEW-EURODRIVE GmbH & Co KG Domagkstraße 5 D-85551 Kirchheim	Tel. +49 89 90955-110 Fax +49 89 90955-150 tb-muenchen@sew-eurodrive.de	
Münster	SEW-EURODRIVE GmbH & Co KG Hafenplatz 4 D-48155 Münster	Tel. +49 251 41475-11 Fax +49 251 41475-50 tb-muenster@sew-eurodrive.de	



Germany			
	Nürnberg	SEW-EURODRIVE GmbH & Co KG Plattenäckerweg 6 D-90455 Nürnberg	Tel. +49 911 98884-50 Fax +49 911 98884-60 tb-nuernberg@sew-eurodrive.de
	Regensburg	SEW-EURODRIVE GmbH & Co KG Im Gewerbepark A15 D-93059 Regensburg	Tel. +49 941 46668-68 Fax +49 941 46668-66 tb-regensburg@sew-eurodrive.de
	Rhein-Main	SEW-EURODRIVE GmbH & Co KG Niederstedter Weg 5 D-61348 Bad Homburg	Tel. +49 6172 9617-0 Fax +49 6172 9617-50 tb-rheinmain@sew-eurodrive.de
	Stuttgart	SEW-EURODRIVE GmbH & Co KG Friedrich-List-Straße 46 D-70771 Leinfelden-Echterdingen	Tel. +49 711 16072-0 Fax +49 711 16072-72 tb-stuttgart@sew-eurodrive.de
	Ulm	SEW-EURODRIVE GmbH & Co KG Dieselstraße 14 D-89160 Dornstadt	Tel. +49 7348 9885-0 Fax +49 7348 9885-90 tb-ulm@sew-eurodrive.de
	Würzburg	SEW-EURODRIVE GmbH & Co KG Nürnbergerstraße 118 D-97076 Würzburg-Lengfeld	Tel. +49 931 27886-60 Fax +49 931 27886-66 tb-wuerzburg@sew-eurodrive.de
	Zwickau / Meerane	SEW-EURODRIVE GmbH & Co KG Dänkritzer Weg1 D-08393 Meerane	Tel. +49 3764 7606-0 Fax +49 3764 7606-20 tb-zwickau@sew-eurodrive.de
France			
Production Sales Service	Hagenau	SEW-USOCOME 48-54 route de Soufflenheim B. P. 20185 F-67506 Hagenau Cedex	Tel. +33 3 88 73 67 00 Fax +33 3 88 73 66 00 http://www.usocome.com sew@usocome.com
Production	Forbach	SEW-USOCOME Zone industrielle Technopôle Forbach Sud B. P. 30269 F-57604 Forbach Cedex	Tel. +33 3 87 29 38 00
Assembly Sales Service	Bordeaux	SEW-USOCOME Parc d'activités de Magellan 62 avenue de Magellan - B. P. 182 F-33607 Pessac Cedex	Tel. +33 5 57 26 39 00 Fax +33 5 57 26 39 09
	Lyon	SEW-USOCOME Parc d'affaires Roosevelt Rue Jacques Tati F-69120 Vaulx en Velin	Tel. +33 4 72 15 37 00 Fax +33 4 72 15 37 15
	Nantes	SEW-USOCOME Parc d'activités de la forêt 4 rue des Fontenelles F-44140 Le Bignon	Tel. +33 2 40 78 42 00 Fax +33 2 40 78 42 20
	Paris	SEW-USOCOME Zone industrielle 2 rue Denis Papin F-77390 Verneuil l'Etang	Tel. +33 1 64 42 40 80 Fax +33 1 64 42 40 88
Technical Offices	Alsace	SEW-USOCOME 1 rue Auguste Gasser F-68360 Sultz	Tel. +33 3 89 74 51 62 Fax +33 3 89 76 58 71
	Aquitaine / Char- entes	SEW-USOCOME Parc d'activités de Magellan 62 avenue de Magellan B. P. 182 F-33607 Pessac Cedex	Tel. +33 5 57 26 39 00 Fax +33 5 57 26 39 09



France		
Auvergne / Limousin	SEW-USOCOME Farges F-19600 Chateaux	Tel. +33 5 55 20 12 10 Fax +33 5 55 20 12 11
Lower Normandy	SEW-USOCOME 5 rue de la Limare F-14250 Brouay	Tel. +33 2 31 37 92 86 Fax +33 2 31 74 68 15
Bourgogne	SEW-USOCOME 10 rue de la poste F-71350 Saint Loup Géanges	Tel. +33 3 85 49 92 18 Fax +33 3 85 49 92 19
Brittany	SEW-USOCOME Parc d'activités de la forêt 4 rue des Fontenelles F-44140 Le Bignon	Tel. +33 2 28 21 12 52 Fax +33 2 28 21 12 84
Centre / Poitou	SEW-USOCOME Parc d'activités de la forêt 4 rue des Fontenelles F-44140 Le Bignon	Tel. +33 2 40 78 42 11 Fax +33 2 40 78 42 20
Champagne-Ardenne	SEW-USOCOME Impasse des Ouisés F-10120 Saint André les Vergers	Tel. +33 3 25 79 63 24 Fax +33 3 25 79 63 25
Franche-Comté	SEW-USOCOME 5 route de Besançon Maison B F-25870 Devecey	Tel. +33 3 81 60 20 47 Fax +33 3 81 87 75 93
Île-de-France East / Aisne	SEW-USOCOME 45 rue des Cinelles F-77700 Bailly Romainvilliers	Tel. +33 1 64 17 02 47 Fax +33 1 64 17 66 49
Île-de-France North / Picardy	SEW-USOCOME 25bis rue Kléber F-92300 Levallois Perret	Tel. +33 1 41 05 92 74 Fax +33 1 41 05 92 75
Île-de-France South	SEW-USOCOME 6 chemin des bergers Lieu-dit Marchais F-91410 Roinville sous Dourdan	Tel. +33 1 60 81 10 56 Fax +33 1 60 81 10 57
Lorraine / Alsace North	SEW-USOCOME 1 rue de la forêt F-54250 Champigneulles	Tel. +33 3 83 96 28 04 Fax +33 3 83 96 28 07
Midi-Pyrénées / Roussillon	SEW-USOCOME 179 route de Grazac F-31190 Caujac	Tel. +33 5 61 08 15 85 Fax +33 5 61 08 16 44
Nord-Pas-de-Calais	SEW-USOCOME 209 route d'Hesdigneul F-62360 Hesdin l'Abbé	Tel. +33 3 21 10 86 86 Fax +33 3 21 10 86 87
Paris / Île-de-France West	SEW-USOCOME 42 avenue Jean Jaurès F-78580 Maule	Tel. +33 1 30 90 89 86 Fax +33 1 30 90 93 15
Pays de la Loire	SEW-USOCOME Parc d'activités de la forêt 4 rue des Fontenelles F-44140 Le Bignon	Tel. +33 2 51 70 54 04 Fax +33 2 51 70 54 05
Provence-Alpes-Côte d'Azur	SEW-USOCOME Résidence Les Hespérides Bât. B2 67 boulevard des Alpes F-13012 Marseille	Tel. +33 4 91 18 00 11 Fax +33 4 91 18 00 12



France			
	Rhône-Alpes East	SEW-USOCOME Montée de la Garenne F-26750 Génissieux	Tel. +33 4 75 05 65 95 Fax +33 4 75 05 65 96
	Rhône-Alpes North	SEW-USOCOME Parc d'affaires Roosevelt Rue Jacques Tati F-69120 Vaulx en Velin	Tel. +33 4 72 15 37 03 Fax +33 4 72 15 37 15
	Rhône-Alpes West	SEW-USOCOME Parc d'affaires Roosevelt Rue Jacques Tati F-69120 Vaulx en Velin	Tel. +33 4 72 15 37 04 Fax +33 4 72 15 37 15
Algeria			
Sales	Alger	REDUCOM Sarl 16, rue des Frères Zaghounne Bellevue 16200 El Harrach Alger	Tel. +213 21 8214-91 Fax +213 21 8222-84 info@reducom-dz.com http://www.reducom-dz.com
Argentina			
Assembly Sales Service	Buenos Aires	SEW EURODRIVE ARGENTINA S.A. Centro Industrial Garin, Lote 35 Ruta Panamericana Km 37,5 1619 Garin	Tel. +54 3327 4572-84 Fax +54 3327 4572-21 sewar@sew-eurodrive.com.ar http://www.sew-eurodrive.com.ar
Australia			
Assembly Sales Service	Melbourne	SEW-EURODRIVE PTY. LTD. 27 Beverage Drive Tullamarine, Victoria 3043	Tel. +61 3 9933-1000 Fax +61 3 9933-1003 http://www.sew-eurodrive.com.au enquires@sew-eurodrive.com.au
	Sydney	SEW-EURODRIVE PTY. LTD. 9, Sleigh Place, Wetherill Park New South Wales, 2164	Tel. +61 2 9725-9900 Fax +61 2 9725-9905 enquires@sew-eurodrive.com.au
Sales Service	Adelaide	SEW-EURODRIVE PTY. LTD. 9C Park Way Mawson Lakes, SA 5095	Tel. +61 8 8161 4000 Fax +61 8 8161 4002 enquires@sew-eurodrive.com.au
	Brisbane	SEW-EURODRIVE PTY.LTD. 1 /34 Collinsvale St Rocklea, Queensland, 4106	Tel. +61 7 3276 5100 Fax +61 7 3276 5102 enquires@sew-eurodrive.com.au
	Perth	SEW-EURODRIVE PTY. LTD. 10 Colin Jamieson Drive Welshpool, WA 6106	Tel. +61 8 9251-4900 Fax +61 8 9251-4903 enquires@sew-eurodrive.com.au
Technical Office	Townsville	SEW-EURODRIVE PTY. LTD. 12 Leyland Street Garbutt, QLD 4814	Tel. +61 7 4779 4333 Fax +61 7 4779 5333 enquires@sew-eurodrive.com.au
Austria			
Assembly Sales Service	Wien	SEW-EURODRIVE Ges.m.b.H. Richard-Strauss-Strasse 24 A-1230 Wien	Tel. +43 1 617 55 00-0 Fax +43 1 617 55 00-30 http://www.sew-eurodrive.at sew@sew-eurodrive.at
Technical Offices	Linz	SEW-EURODRIVE Ges.m.b.H. Reuchlinstr. 6/3 A-4020 Linz	Tel. +43 732 655 109-0 Fax +43 732 655 109-20 tb-linz@sew-eurodrive.at
	Graz	SEW-EURODRIVE Ges.m.b.H. Grabenstraße 231 A-8045 Graz	Tel. +43 316 685 756-0 Fax +43 316 685 755 tb-graz@sew-eurodrive.at



Austria			
	Dornbirn	SEW-EURODRIVE Ges.m.b.H. Lustenauerstraße 27/1 A-6850 Dornbirn	Tel. +43 5572 3725 99-0 Fax +43 5572 3725 99-20 tb-dornbirn@sew-eurodrive.at
Bangladesh			
Sales	Dhaka	Jainex Industrial and Engineering Ltd B 12 Apon Nibash East Nasirabad Bangladesh	Tel. +880 1713103502 Fax +880 31 613041 jainexbd@onlinectg.net
Belarus			
Sales	Minsk	SEW-EURODRIVE BY RybalkoStr. 26 BY-220033 Minsk	Tel.+375 (17) 298 38 50 Fax +375 (17) 29838 50 sales@sew.by
Belgium			
Assembly Sales Service	Brussels	SEW Caron-Vector Research park Haasrode Evenementenlaan 7 BE-3001 Leuven	Tel. +32 16 386-311 Fax +32 16 386-336 http://www.sew-eurodrive.be info@sew-eurodrive.be
Service Competence Center	Industrial Gears	SEW Caron-Vector Rue de Parc Industriel, 31 BE-6900 Marche-en-Famenne	Tel. +32 84 219-878 Fax +32 84 219-879 http://www.sew-eurodrive.be service-wallonie@sew-eurodrive.be
	Antwerp	SEW Caron-Vector Glasstraat, 19 BE-2170 Merksem	Tel. +32 3 64 19 333 Fax +32 3 64 19 336 http://www.sew-eurodrive.be service-antwerpen@sew-eurodrive.be
Brazil			
Production Sales Service	Sao Paulo	SEW-EURODRIVE Brasil Ltda. Avenida Amâncio Gaiolli, 152 - Rodovia Presidente Dutra Km 208 Guarulhos - 07251-250 - SP SAT - SEW ATENDE - 0800 7700496	Tel. +55 11 2489-9133 Fax +55 11 2480-3328 http://www.sew-eurodrive.com.br sew@sew.com.br
Bulgaria			
Sales	Sofia	BEVER-DRIVE GmbH Bogdanovetz Str.1 BG-1606 Sofia	Tel. +359 2 9151160 Fax +359 2 9151166 bever@mail.bg
Cameroon			
Sales	Douala	Electro-Services Rue Drouot Akwa B.P. 2024 Douala	Tel. +237 33 431137 Fax +237 33 431137 electrojemba@yahoo.fr
Canada			
Assembly Sales Service	Toronto	SEW-EURODRIVE CO. OF CANADA LTD. 210 Walker Drive Bramalea, ON L6T 3W1	Tel. +1 905 791-1553 Fax +1 905 791-2999 http://www.sew-eurodrive.ca l.watson@sew-eurodrive.ca
	Vancouver	SEW-EURODRIVE CO. OF CANADA LTD. Tilbury Industrial Park 7188 Honeyman Street Delta, BC V4G 1G1	Tel. +1 604 946-5535 Fax +1 604 946-2513 b.wake@sew-eurodrive.ca
	Montreal	SEW-EURODRIVE CO. OF CANADA LTD. 2555 Rue Leger Lasalle, PQ H8N 2V9	Tel. +1 514 367-1124 Fax +1 514 367-3677 a.peluso@sew-eurodrive.ca



Canada			
Additional addresses for service in Canada provided on request!			
Chile			
Assembly Sales Service	Santiago de Chile	SEW-EURODRIVE CHILE LTDA. Las Encinas 1295 Parque Industrial Valle Grande LAMP RCH-Santiago de Chile P.O. Box Casilla 23 Correo Quilicura - Santiago - Chile	Tel. +56 2 75770-00 Fax +56 2 75770-01 http://www.sew-eurodrive.cl ventas@sew-eurodrive.cl
China			
Production Assembly Sales Service	Tianjin	SEW-EURODRIVE (Tianjin) Co., Ltd. No. 46, 7th Avenue, TEDA Tianjin 300457	Tel. +86 22 25322612 Fax +86 22 25323273 info@sew-eurodrive.cn http://www.sew-eurodrive.com.cn
Assembly Sales Service	Suzhou	SEW-EURODRIVE (Suzhou) Co., Ltd. 333, Suhong Middle Road Suzhou Industrial Park Jiangsu Province, 215021	Tel. +86 512 62581781 Fax +86 512 62581783 suzhou@sew-eurodrive.cn
	Guangzhou	SEW-EURODRIVE (Guangzhou) Co., Ltd. No. 9, JunDa Road East Section of GETDD Guangzhou 510530	Tel. +86 20 82267890 Fax +86 20 82267922 guangzhou@sew-eurodrive.cn
	Shenyang	SEW-EURODRIVE (Shenyang) Co., Ltd. 10A-2, 6th Road Shenyang Economic Technological Development Area Shenyang, 110141	Tel. +86 24 25382538 Fax +86 24 25382580 shenyang@sew-eurodrive.cn
	Wuhan	SEW-EURODRIVE (Wuhan) Co., Ltd. 10A-2, 6th Road No. 59, the 4th Quanli Road, WEDA 430056 Wuhan	Tel. +86 27 84478388 Fax +86 27 84478389 wuhan@sew-eurodrive.cn
	Xi'An	SEW-EURODRIVE (Xi'An) Co., Ltd. No. 12 Jinye 2nd Road Xi'An High-Technology Industrial Development Zone Xi'An 710065	Tel. +86 29 68686262 Fax +86 29 68686311 xian@sew-eurodrive.cn
Colombia			
Assembly Sales Service	Bogotá	SEW-EURODRIVE COLOMBIA LTDA. Calle 22 No. 132-60 Bodega 6, Manzana B Santafé de Bogotá	Tel. +57 1 54750-50 Fax +57 1 54750-44 http://www.sew-eurodrive.com.co sewcol@sew-eurodrive.com.co
Croatia			
Sales Service	Zagreb	KOMPEKS d. o. o. Zeleni dol 10 HR 10 000 Zagreb	Tel. +385 1 4613-158 Fax +385 1 4613-158 kompeks@inet.hr
Czech Republic			
Sales	Prague	SEW-EURODRIVE CZ S.R.O. Business Centrum Praha Lužná 591 CZ-16000 Praha 6 - Vokovice	Tel. +420 255 709 601 Fax +420 220 121 237 http://www.sew-eurodrive.cz sew@sew-eurodrive.cz
Technical Offices	Brno	SEW-EURODRIVE CZ S.R.O. Křenová 52 CZ -60200 Brno	Tel. +420 543 256 151 +420 543 256 163 Fax +420 543 256 845



Czech Republic			
	Hradec Králové	SEW-EURODRIVE CZ S.R.O. Čechova 498 CZ-50202 Hradec Králové	Tel. +420 495 510 141 Fax +420 495 521 313
	Plzeň	SEW-EURODRIVE CZ S.R.O. Areal KRPA a.s. Zahradni 173/2 CZ-32600 Plzeň	Tel. +420 378 775 300 Fax +420 377 970 710
	Ostrava	SEW-EURODRIVE CZ S.R.O. Studentská 6202/17 CZ-708 00 Ostrava-Poruba	Tel. +420 597 329 044 Mobile +420 724 889 965
	Klatovy	SEW-EURODRIVE CZ S.R.O. Technická kancelář Klatovy Domažlická 800 CZ-33901 Klatovy	Tel. +420 376 310 729 Fax +420 376 310 725
Denmark			
Assembly Sales Service	Copenhagen	SEW-EURODRIVEA/S Geminivej 28-30 DK-2670 Greve	Tel. +45 43 9585-00 Fax +45 43 9585-09 http://www.sew-eurodrive.dk sew@sew-eurodrive.dk
Egypt			
Sales Service	Cairo	Copam Egypt for Engineering & Agencies 33 El Hegaz ST, Heliopolis, Cairo	Tel. +20 2 22566-299 + 1 23143088 Fax +20 2 22594-757 http://www.copam-egypt.com/ copam@datum.com.eg
Estonia			
Sales	Tallin	ALAS-KUUL AS Reti tee 4 EE-75301 Peetri küla, Rae vald, Harjumaa	Tel. +372 6593230 Fax +372 6593231 veiko.soots@alas-kuul.ee
Finland			
Assembly Sales Service	Lahti	SEW-EURODRIVE OY Vesimäentie 4 FIN-15860 Hollola 2	Tel. +358 201 589-300 Fax +358 3 780-6211 http://www.sew-eurodrive.fi sew@sew.fi
Technical Offices	Helsinki	SEW-EURODRIVE OY Luutnantintie 5 FIN-00410 Helsinki	Tel. +358 201 589-300 Fax + 358 9 5666-311 sew@sew.fi
	Vaasa	SEW-EURODRIVE OY Hietasaarenkatu 18 FIN-65100 Vaasa	Tel. +358 201 589-300 Fax +358 6 3127-470 sew@sew.fi
	Rovaniemi	SEW-EURODRIVE OY Valtakatu 4 A FIN-96100 Rovaniemi	Tel. +358 201 589-300 Fax +358 201 589-239 sew@sew.fi
Production Assembly	Karkkila	SEW Industrial Gears Oy Valurinkatu 6, PL 8 FI-03600 Karkkila, 03601 Karkkila	Tel. +358 201 589-300 Fax +358 201 589-310 sew@sew.fi http://www.sew-eurodrive.fi
Gabon			
Sales	Libreville	ESG Electro Services Gabun Feu Rouge Lalala 1889 Libreville Gabun	Tel. +241 741059 Fax +241 741059 esg_services@yahoo.fr



Great Britain			
Assembly Sales Service	Normanton	SEW-EURODRIVE Ltd. Beckbridge Industrial Estate P.O. Box No.1 Normanton, West-Yorkshire WF6 1QR	Tel. +44 1924 893-855 Fax +44 1924 893-702 http://www.sew-eurodrive.co.uk info@sew-eurodrive.co.uk
Technical Offices	London	SEW-EURODRIVE Ltd. 764 Finchely Road, Temple Fortune London N.W.11 7TH	Tel. +44 20 8458-8949 Fax +44 20 8458-7417
	Midlands	SEW-EURODRIVE Ltd. 5 Sugar Brook court, Aston Road, Bromsgrove, Worcs B60 3EX	Tel. +44 1527 877-319 Fax +44 1527 575-245
	Scotland	SEW-EURODRIVE Ltd. Scottish Office No 37 Enterprise House Springkerse Business Park Stirling FK7 7UF Scotland	Tel. +44 17 8647-8730 Fax +44 17 8645-0223
Greece			
Sales Service	Athens	Christ. Boznos & Son S.A. 12, K. Mavromichali Street P.O. Box 80136 GR-18545 Piraeus	Tel. +30 2 1042 251-34 Fax +30 2 1042 251-59 http://www.boznos.gr info@boznos.gr
Technical Office	Thessaloniki	Christ. Boznos & Son S.A. Asklipiou 26 562 24 Evosmos, Thessaloniki	Tel. +30 2 310 7054-00 Fax +30 2 310 7055-15 info@boznos.gr
Hong Kong			
Assembly Sales Service	Hong Kong	SEW-EURODRIVE LTD. Unit No. 801-806, 8th Floor Hong Leong Industrial Complex No. 4, Wang Kwong Road Kowloon, Hong Kong	Tel. +852 36902200 Fax +852 36902211 contact@sew-eurodrive.hk
Hungary			
Sales Service	Budapest	SEW-EURODRIVE Kft. H-1037 Budapest Kunigunda u. 18	Tel. +36 1 437 06-58 Fax +36 1 437 06-50 office@sew-eurodrive.hu
Iceland			
Sales	Reykjavik	Vélaverk ehf. Bolholti 8, 3h. IS - 105 Reykjavik	Tel. +354 568 3536 Fax +354 568 3537 velaverk@velaverk.is
India			
Registered Office Assembly Sales Service	Vadodara	SEW-EURODRIVE India Private Limited Plot No. 4, GIDC POR Ramangamdi • Vadodara - 391 243 Gujarat	Tel. +91 265 3045200, +91 265 2831086 Fax +91 265 3045300, +91 265 2831087 http://www.seweurodriveindia.com sales@seweurodriveindia.com subodh.ladwa@seweurodriveindia.com



India			
Assembly Sales Service	Chennai	SEW-EURODRIVE India Private Limited Plot No. K3/1, Sipcot Industrial Park Phase II Mambakkam Village Sriperumbudur - 602105 Kancheepuram Dist, Tamil Nadu	Tel. +91 44 37188888 Fax +91 44 37188811 c.v.shivkumar@seweurodriveindia.com
Technical Offices	Ahmedabad	SEW-EURODRIVE India Private Limited 306, Shaan office complex, Behind Sakar-IV, Ellisebridge, Ashram Road Ahmedabad – Gujarat	Tel. +91 79 40072067/68 Fax +91 79 40072069 subodh.ladwa@seweurodriveindia.com
	Bengaluru	SEW-EURODRIVE India Private Limited 308, Prestige Centre Point 7, Edward Road Bengaluru - 560052 - Karnataka	Tel. +91 80 22266565 Fax +91 80 22266569 salesbang@seweurodriveindia.com ganesh@seweurodriveindia.com
	Chennai	SEW-EURODRIVE India Private Limited 2nd Floor, Josmans Complex, No. 5, McNichols Road, Chetpet Chennai - 600031 - Tamil Nadu	Tel. +91 44 42849813 Fax +91 44 42849816 saleschen@seweurodriveindia.com c.v.shivkumar@seweurodriveindia.com
	Coimbatore	SEW-EURODRIVE India Private Limited Office No 60 Arpee Centre (Opp Annapoorna Hotel) 420 N, NSR Road, Saibaba Colony Coimbatore 641 0111 - Tamil Nadu	Tel. +91 422 2455420 Fax +91 422 2443988 salescmb@seweurodriveindia.com p.selvakumar@seweurodriveindia.com
	Cuttack	SEW-EURODRIVE India Private Limited Plot No.- 1764, Nuasahi, Nayapalli Bhubaneswar-12 Orissa	Tel. +91 9937446333 manoranjana.sahoo@seweurodriveindia.com
	Hyderabad	SEW-EURODRIVE India Private Limited 408, 4th Floor, Meridian Place Green Park Road Amerpet Hyderabad - 500016 - Andhra Pradesh	Tel. +91 40 23414698 Fax +91 40 23413884 saleshyd@seweurodriveindia.com ma.choudary@seweurodriveindia.com
	Jamshedpur	SEW-EURODRIVE India Private Limited Flat No.: B/2, B.S. Apartment Road No.: 4, Contractor's area, Bistupur Jamshedpur 831 001 - Chhattisgarh	Tel. +91 9934123671 siddaratha.mishra@seweurodriveindia.com
	Kolkata	SEW EURODRIVE India Private Limited 2nd floor, Room No. 35 Chowringhee Court 55, Chowringhee Road Kolkata - 700 071 - West Bengal	Tel. +91 33 22827457 Fax +91 33 22894204 saleskal@seweurodriveindia.com a.j.biswas@seweurodriveindia.com
	Lucknow	SEW-EURODRIVE India Private Limited 69, Shiv Vihar Colony Vikas Nagar-5 Lucknow 226022 - Uttar Pradesh	Tel. +91 9793627333 amit.nigam@seweurodriveindia.com
	Mumbai	SEW-EURODRIVE India Private Limited 312 A, 3rd Floor, Acme Plaza, J.B. Nagar, Andheri Kurla Road, Andheri (E) Mumbai - 400059 - Maharashtra	Tel. +91 22 28348440 Fax +91 22 28217858 salesmumbai@seweurodriveindia.com p.s.ray@seweurodriveindia.com
	Nagpur	SEW-EURODRIVE India Private Limited Piyush S .Kudawale Ganga Residency, 204, Shahu Nagar, Manewada-Besa Road, Post- Mhalgi Nagar, Nagpur - 440034	Tel. +91 9561089525 piyush.kudawale@seweurodriveindia.com



India			
	New Delhi	SEW-EURODRIVE India Private Limited 418-419, Suneja Tower-1 District Centre, Janak Puri New Delhi 110 058	Tel. +91 11 25544111 Fax +91 11 25544113 salesdelhi@seweurodriveindia.com vikram.juneja@seweurodriveindia.com
	Pune	SEW-EURODRIVE India Private Limited Lunawat Prism 4th floor, S. No. 148, Neena Co-Operative Housing Society, Paud Road, Pune 411038 - Maharashtra	Tel. +91 20 25380730 / 735 Fax +91 20 25380721 salespune@seweurodriveindia.com praveen.hosur@seweurodriveindia.com
	Raipur	SEW-EURODRIVE India Private Limited A-42, Ashoka Millenium Complex, Ring Road-1, Raipur 492 001 - Chhattisgarh	Tel. +91 771 4090765 Fax +91 771 4090765 sutanu.sarkar@seweurodriveindia.com
Indonesia			
Sales	Medan II	PT. Serumpun Indah Lestari Jl. Pulau Solor NO. 8 Kawasan Industri Medan II	Tel. +62 61 687 1221 Fax +62 61 687 1429 serumpunindah@yahoo.com
Ireland			
Sales Service	Dublin	Alperton Engineering Ltd. 48 Moyle Road Dublin Industrial Estate Glasnevin, Dublin 11	Tel. +353 1 830-6277 Fax +353 1 830-6458 info@alperton.ie http://www.alperton.ie
Israel			
Sales	Tel-Aviv	Liraz Handasa Ltd. Ahofer Str 34B / 228 58858 Holon	Tel. +972 3 5599511 Fax +972 3 5599512 http://www.liraz-handasa.co.il office@liraz-handasa.co.il
Italy			
Assembly Sales Service	Solaro	SEW-EURODRIVE di R. Blickle & Co.s.a.s. Via Bernini,14 I-20020 Solaro (Milano)	Tel. +39 02 96 9801 Fax +39 02 96 799781 http://www.sew-eurodrive.it sewit@sew-eurodrive.it
Technical Offices	Bologna	SEW-EURODRIVE di R. Blickle & Co.s.a.s. Via della Grafica, 47 I-40064 Ozzano dell'Emilia (Bo)	Tel. +39 051 65-23-801 Fax +39 051 796-595
	Caserta	SEW-EURODRIVE di R. Blickle & Co.s.a.s. Viale Carlo III Km. 23,300 I-81020 S. Nicola la Strada (Caserta)	Tel. +39 0823 219011 Fax +39 0823 421414
	Milan	SEW-EURODRIVE di R. Blickle & Co.s.a.s. Via Bernini,14 I-20020 Solaro (Milano)	Tel. +39 02 96 980229 Fax +39 02 96 799781
	Pescara	SEW-EURODRIVE di R. Blickle & Co.s.a.s. Viale Europa,132 I-65010 Villa Raspa di Spoltore (PE)	Tel. +39 085 41-59-427 Fax +39 085 41-59-643
	Torino	SEW-EURODRIVE di R. Blickle & Co.s.a.s. Filiale Torino c.so Unione Sovietica 612/15 - int. C I-10135 Torino	Tel. +39 011 3473780 Fax +39 011 3473783
	Verona	SEW-EURODRIVE di R. Blickle & Co.s.a.s. Via P. Sgulmero, 27/A I-37132 Verona	Tel. +39 045 89-239-11 Fax +39 045 97-6079



Ivory Coast			
Sales	Abidjan	SICA Société industrielle & commerciale pour l'Afrique 165, Boulevard de Marseille 26 BP 1115 Abidjan 26	Tel. +225 21 25 79 44 Fax +225 21 25 88 28 sicamot@aviso.ci
Japan			
Assembly Sales Service	Iwata	SEW-EURODRIVE JAPAN CO., LTD 250-1, Shimoman-no, Iwata Shizuoka 438-0818	Tel. +81 538 373811 Fax +81 538 373855 http://www.sew-eurodrive.co.jp sewjapan@sew-eurodrive.co.jp
Technical Offices	Fukuoka	SEW-EURODRIVE JAPAN CO., LTD. C-go, 5th-floor, Yakuin-Hiruzu-Bldg. 1-5-11, Yakuin, Chuo-ku Fukuoka, 810-0022	Tel. +81 92 713-6955 Fax +81 92 713-6860 sewkyushu@jasmine.ocn.ne.jp
	Osaka	SEW-EURODRIVE JAPAN CO., LTD. Higobashi Shimizu Bldg. 10th floor 1-3-7 Tosabori, Nishi-ku Osaka, 550-0001	Tel. +81 6 6444--8330 Fax +81 6 6444--8338 sewosaka@crocus.ocn.ne.jp
	Tokyo	SEW-EURODRIVE JAPAN CO., LTD. Omarimon Yusen Bldg. 13th floor 3-23-5 Nishinbashi, Minato-ku Tokyo 105-0003	Tel. +81 3 3239-0469 Fax +81 3 3239-0943 sewtokyo@basil.ocn.ne.jp
Kazakhstan			
Sales	Almaty	TOO "СЕВ-ЕВРОДРАЙВ" 050061, Республика Казахстан г.Алматы, пр.Райымбека, 348	Тел. +7 (727) 334 1880 Факс +7 (727) 334 1881 http://www.sew-eurodrive.kz sew@sew-eurodrive.kz
Latvia			
Sales	Riga	SIA Alas-Kuul Katlakalna 11C LV-1073 Riga	Tel. +371 6 7139253 Fax +371 6 7139386 http://www.alas-kuul.com info@alas-kuul.com
Lebanon			
Sales	Beirut	Gabriel Acar & Fils sarl B. P. 80484 Bourj Hammoud, Beirut	Tel. +961 1 510 532 Fax +961 1 494 971 ssacar@inco.com.lb
Jordan Kuwait Saudi Arabia Syria	Beirut	Middle East Drives S.A.L. (offshore) Sin El Fil. B. P. 55-378 Beirut	Tel. +961 1 494 786 Fax +961 1 494 971 info@medrives.com http://www.medrives.com
Lithuania			
Sales	Alytus	UAB Irseva Statybininku 106C LT-63431 Alytus	Tel. +370 315 79204 Fax +370 315 56175 info@irseva.lt http://www.sew-eurodrive.lt
Luxembourg			
Assembly Sales Service	Brussels	SEW Caron-Vector Research park Haasrode Evenementenlaan 7 BE-3001 Leuven	Tel. +32 16 386-311 Fax +32 16 386-336 http://www.sew-eurodrive.be info@sew-eurodrive.be



Malaysia			
Assembly Sales Service	Johore	SEW-EURODRIVE SDN BHD No. 95, Jalan Seroja 39, Taman Johor Jaya 81000 Johor Bahru, Johor West Malaysia	Tel. +60 7 3549409 Fax +60 7 3541404 sales@sew-eurodrive.com.my
Technical Offices	Kota Kinabalu	SEW-EURODRIVE Sdn Bhd (Kota Kinabalu Branch) Lot No. 2, 1st Floor, Inanam Baru Phase III, Miles 5.1 /2, Jalan Tuaran, Inanam 89350 Kota Kinabalu Sabah, Malaysia	Tel. +60 88 424792 Fax +60 88 424807
	Kuala Lumpur	SEW-EURODRIVE Sdn. Bhd. No. 2, Jalan Anggerik Mokara 31/46 Kota Kemuning Seksyen 31 40460 Shah Alam Selangor Darul Ehsan	Tel. +60 3 5229633 Fax +60 3 5229622 sewpjy@po.jaring.my
	Kuching	SEW-EURODRIVE Sdn. Bhd. Lot 268, Section 9 KTL D Lorong 9, Jalan Satok 93400 Kuching, Sarawak East Malaysia	Tel. +60 82 232380 Fax +60 82 242380
	Penang	SEW-EURODRIVE Sdn. Bhd. No. 38, Jalan Bawal Kimsar Garden 13700 Prai, Penang	Tel. +60 4 3999349 Fax +60 4 3999348 seweurodrive@po.jaring.my
Mauritania			
Sales	Zouérate	AFRICOM - SARL En Face Marché Dumez P.B. 88 Zouérate	Tel. +222 544 0 314 Fax +222 544 0 538 cybertiris@mauritel.mr
Mexico			
Assembly Sales Service	Quéretaro	SEW-EURODRIVE MEXICO SA DE CV SEM-981118-M93 Tequisquiapan No. 102 Parque Industrial Quéretaro C.P. 76220 Quéretaro, México	Tel. +52 442 1030-300 Fax +52 442 1030-301 http://www.sew-eurodrive.com.mx scmexico@seweurodrive.com.mx
Morocco			
Sales	Casablanca	Afit Route D'El Jadida KM 14 RP8 Province de Nouaceur Commune Rurale de Bouskoura MA 20300 Casablanca	Tel. +212 522633700 Fax +212 522621588 fatima.haqui@premium.net.ma http://www.groupe-premium.com
Netherlands			
Assembly Sales Service	Rotterdam	VECTOR Aandrijftechniek B.V. Industrieweg 175 NL-3044 AS Rotterdam Postbus 10085 NL-3004 AB Rotterdam	Tel. +31 10 4463-700 Fax +31 10 4155-552 http://www.vector.nu info@vector.nu
New Zealand			
Assembly Sales Service	Auckland	SEW-EURODRIVE NEW ZEALAND LTD. P.O. Box 58-428 82 Greenmount drive East Tamaki Auckland	Tel. +64 9 2745627 Fax +64 9 2740165 http://www.sew-eurodrive.co.nz sales@sew-eurodrive.co.nz



New Zealand			
	Christchurch	SEW-EURODRIVE NEW ZEALAND LTD. 10 Settlers Crescent, Ferrymead Christchurch	Tel. +64 3 384-6251 Fax +64 3 384-6455 sales@sew-eurodrive.co.nz
Technical Office	Palmerston North	SEW-EURODRIVE NEW ZEALAND LTD. C/-Grant Shearman, RD 5, Aronui Road Palmerston North	Tel. +64 6 355-2165 Fax +64 6 355-2316 sales@sew-eurodrive.co.nz
Norway			
Assembly Sales Service	Moss	SEW-EURODRIVE A/S Solgaard skog 71 N-1599 Moss	Tel. +47 69 24 10 20 Fax +47 69 24 10 40 http://www.sew-eurodrive.no sew@sew-eurodrive.no
Pakistan			
Sales	Karachi	Industrial Power Drives Al-Fatah Chamber A/3, 1st Floor Central Commercial Area, Sultan Ahmed Shah Road, Block 7/8, Karachi	Tel. +92 21 452 9369 Fax +92-21-454 7365 seweurodrive@cyber.net.pk
Peru			
Assembly Sales Service	Lima	SEW DEL PERU MOTORES REDUCTORES S.A.C. Los Calderos, 120-124 Urbanizacion Industrial Vulcano, ATE, Lima	Tel. +51 1 3495280 Fax +51 1 3493002 http://www.sew-eurodrive.com.pe sewperu@sew-eurodrive.com.pe
Poland			
Assembly Sales Service	Lodz	SEW-EURODRIVE Polska Sp.z.o.o. ul. Techniczna 5 PL-92-518 Łódź	Tel. +48 42 676 53 00 Fax +48 42 676 53 45 http://www.sew-eurodrive.pl sew@sew-eurodrive.pl
	24 Hour Service		Tel. +48 602 739 739 (+48 602 SEW SEW) serwis@sew-eurodrive.pl
Technical Office	Tychy	SEW-EURODRIVE Polska Sp.z.o.o. ul. Fabryczna 5 PL-43-100 Tychy	Tel. +48 32 32 32 610 Fax +48 32 32 32 647
	Bydgoszcz	SEW-EURODRIVE Polska Sp.z.o.o. ul. Fordońska 246 PL-85-959 Bydgoszcz	Tel. +48 52 3606590 Fax +48 52 3606591
	Poznan	SEW-EURODRIVE Polska Sp.z.o.o. ul. Romana Maya 1 PL-61-371 Poznań	Tel. +48 61 8741640 Fax +48 61 8741641
	Radom	SEW-EURODRIVE Polska Sp.z.o.o. ul. Słowackiego 84 PL-26-600 Radom	Tel. +48 48 365 40 50 Fax +48 48 365 40 51
Portugal			
Assembly Sales Service	Coimbra	SEW-EURODRIVE, LDA. Apartado 15 P-3050-901 Mealhada	Tel. +351 231 20 9670 Fax +351 231 20 3685 http://www.sew-eurodrive.pt infosew@sew-eurodrive.pt
Technical Offices	Lisboa	SEW-EURODRIVE, LDA. Núcleo Empresarial I de São Julião do Tojal Rua de Entremuros, 54 Fracção I P-2660-533 São Julião do Tojal	Tel. +351 21 958-0198 Fax +351 21 958-0245 esc.lisboa@sew-eurodrive.pt



Portugal			
	Porto	SEW-EURODRIVE, LDA. Av. 25 de Abril, 68 4440-502 Valongo	Tel. +351 229 350 383 Fax +351 229 350 384 MobilTel. +351 9 32559110 esc.porto@sew-eurodrive.pt
Romania			
Sales Service	Bucharest	Sialco Trading SRL str. Madrid nr.4 011785 Bucuresti	Tel. +40 21 230-1328 Fax +40 21 230-7170 sialco@sialco.ro
Russia			
Assembly Sales Service	St. Petersburg	ZAO SEW-EURODRIVE P.O. Box 36 195220 St. Petersburg Russia	Tel. +7 812 3332522 +7 812 5357142 Fax +7 812 3332523 http://www.sew-eurodrive.ru sew@sew-eurodrive.ru
Technical Office	Yekaterinburg	ZAO SEW-EURODRIVE Kominterna Str. 16 Office 614 RUS-620078 Ekaterinburg	Tel. +7 343 310 3977 Fax +7 343 310 3978 eso@sew-eurodrive.ru
	Irkutsk	ZAO SEW-EURODRIVE 5-Armii Str., 31 RUS-664011 Irkutsk	Tel. +7 3952 25 5880 Fax +7 3952 25 5881 iso@sew-eurodrive.ru
	Moskau	ZAO SEW-EURODRIVE RUS-107023 Moskau	Tel. +7 495 9337090 Fax +7 495 9337094 mso@sew-eurodrive.ru
	Novosibirsk	ZAO SEW-EURODRIVE pr. K Marksa, d.30 RUS-630087 Novosibirsk	Tel. +7 383 3350200 Fax +7 383 3462544 nso@sew-eurodrive.ru
	Togliatti	ZAO SEW-EURODRIVE Sportivnaya Str. 4B, office 2 Samarskaya obl. RUS-445057 Togliatti	Tel. +7 8482 710529 Fax +7 8482 810590
Senegal			
Sales	Dakar	SENEMECA Mécanique Générale Km 8, Route de Rufisque B.P. 3251, Dakar	Tel. +221 338 494 770 Fax +221 338 494 771 senemeca@sentoo.sn http://www.senemeca.com
Serbia			
Sales	Beograd	DIPAR d.o.o. Ustanicka 128a PC Košum, IV floor SCG-11000 Beograd	Tel. +381 11 347 3244 / +381 11 288 0393 Fax +381 11 347 1337 office@dipar.rs
Singapore			
Assembly Sales Service	Singapore	SEW-EURODRIVE PTE. LTD. No 9, Tuas Drive 2 Jurong Industrial Estate Singapore 638644	Tel. +65 68621701 Fax +65 68612827 http://www.sew-eurodrive.com.sg sewsingapore@sew-eurodrive.com
Slovakia			
Sales	Bratislava	SEW-Eurodrive SK s.r.o. Rybničná 40 SK-831 06 Bratislava	Tel. +421 2 33595 202 Fax +421 2 33595 200 sew@sew-eurodrive.sk http://www.sew-eurodrive.sk



Slovakia			
	Žilina	SEW-Eurodrive SK s.r.o. Industry Park - PChZ ulica M.R.Štefánika 71 SK-010 01 Žilina	Tel. +421 41 700 2513 Fax +421 41 700 2514 sew@sew-eurodrive.sk
	Banská Bystrica	SEW-Eurodrive SK s.r.o. Rudlovska cesta 85 SK-974 11 Banská Bystrica	Tel. +421 48 414 6564 Fax +421 48 414 6566 sew@sew-eurodrive.sk
	Košice	SEW-Eurodrive SK s.r.o. Slovenská ulica 26 SK-040 01 Košice	Tel. +421 55 671 2245 Fax +421 55 671 2254 sew@sew-eurodrive.sk
Slovenia			
Sales Service	Celje	Pakman - Pogonska Tehnika d.o.o. Ul. XIV. divizije 14 SLO - 3000 Celje	Tel. +386 3 490 83-20 Fax +386 3 490 83-21 pakman@siol.net
South Africa			
Assembly Sales Service	Johannesburg	SEW-EURODRIVE (PROPRIETARY) LIMITED Eurodrive House Cnr. Adcock Ingram and Aerodrome Roads Aeroton Ext. 2 Johannesburg 2013 P.O.Box 90004 Bertsham 2013	Tel. +27 11 248-7000 Fax +27 11 494-3104 http://www.sew.co.za info@sew.co.za
	Cape Town	SEW-EURODRIVE (PROPRIETARY) LIMITED Rainbow Park Cnr. Racecourse & Omuramba Road Montague Gardens Cape Town P.O.Box 36556 Chempet 7442 Cape Town	Tel. +27 21 552-9820 Fax +27 21 552-9830 Telex 576 062 cfoster@sew.co.za
	Durban	SEW-EURODRIVE (PROPRIETARY) LIMITED 2 Monaco Place Pinetown Durban P.O. Box 10433, Ashwood 3605	Tel. +27 31 700-3451 Fax +27 31 700-3847 cdejager@sew.co.za
	Nelspruit	SEW-EURODRIVE (PTY) LTD. 7 Christie Crescent Vintonia P.O.Box 1942 Nelspruit 1200	Tel. +27 13 752-8007 Fax +27 13 752-8008 robermeyer@sew.co.za
Technical Offices	Port Elizabeth	SEW-EURODRIVE PTY LTD. 8 Ruan Access Park Old Cape Road Greenbushes 6000 Port Elizabeth	Tel. +27 41 3722246 Fax +27 41 3722247 dtait@sew.co.za
	Richards Bay	SEW-EURODRIVE PTY LTD. 103 Bulion Blvd Richards Bay P.O. Box 458 Richards Bay, 3900	Tel. +27 35 797-3805 Fax +27 35 797-3819 jswart@sew.co.za
South Korea			
Assembly Sales Service	Ansan-City	SEW-EURODRIVE KOREA CO., LTD. B 601-4, Banweol Industrial Estate 1048-4, Shingil-Dong Ansan 425-120	Tel. +82 31 492-8051 Fax +82 31 492-8056 http://www.sew-korea.co.kr master.korea@sew-eurodrive.com



South Korea			
	Busan	SEW-EURODRIVE KOREA Co., Ltd. No. 1720 - 11, Songjeong - dong Gangseo-ku Busan 618-270	Tel. +82 51 832-0204 Fax +82 51 832-0230 master@sew-korea.co.kr
Technical Offices	Daegu	SEW-EURODRIVE KOREA Co., Ltd. No.1108 Sungan officetel 87-36, Duryu 2-dong, Dalseo-ku Daegu 704-712	Tel. +82 53 650-7111 Fax +82 53 650-7112
	DaeJeon	SEW-EURODRIVE KOREA Co., Ltd. No. 1502, Hongin officetel 536-9, Bongmyung-dong, Yusung-ku Daejeon 305-301	Tel. +82 42 828-6461 Fax +82 42 828-6463
	Kwangju	SEW-EURODRIVE KOREA Co., Ltd. 4fl., Dae-Myeong B/D 96-16 Unam-dong, Buk-ku Kwangju 500-170	Tel. +82 62 511-9172 Fax +82 62 511-9174
	Seoul	SEW-EURODRIVE KOREA Co., Ltd. No.504 Sunkyung officetel 106-4 Kuro 6-dong, Kuro-ku Seoul 152-054	Tel. +82 2 862-8051 Fax +82 2 862-8199
Spain			
Assembly Sales Service	Bilbao	SEW-EURODRIVE ESPAÑA, S.L. Parque Tecnológico, Edificio, 302 E-48170 Zamudio (Vizcaya)	Tel. +34 94 43184-70 Fax +34 94 43184-71 http://www.sew-eurodrive.es sew.spain@sew-eurodrive.es
Technical Offices	Barcelona	Delegación Barcelona Avenida Francesc Maciá 40-44 Oficina 4.2 E-08208 Sabadell (Barcelona)	Tel. +34 93 7162200 Fax +34 93 7233007
	Lugo	Delegación Noroeste Apartado, 1003 E-27080 Lugo	Tel. +34 639 403348 Fax +34 982 202934
	Madrid	Delegación Madrid Gran Via. 48-2° A-D E-28220 Majadahonda (Madrid)	Tel. +34 91 6342250 Fax +34 91 6340899
	Seville	MEB Pólogono Calonge, C/A Nave 2 - C E-41.077 Sevilla	Tel. +34 954 356 361 Fax +34 954 356 274 mebsa.sevilla@mebsa.com
	Valencia	MEB Músico Andreu i Piqueres, 4 E-46.900 Torrente (Valencia)	Tel. +34 961 565 493 Fax +34 961 566 688 mebsa.valencia@mebsa.com
Sri Lanka			
Sales	Colombo	SM International (Pte) Ltd 254, Galle Raod Colombo 4, Sri Lanka	Tel. +94 1 2584887 Fax +94 1 2582981
Sweden			
Assembly Sales Service	Jönköping	SEW-EURODRIVE AB Gnejsvägen 6-8 S-55303 Jönköping Box 3100 S-55003 Jönköping	Tel. +46 36 3442 00 Fax +46 36 3442 80 http://www.sew-eurodrive.se jonkoping@sew.se
Sales	Göteborg	SEW-EURODRIVE AB Gustaf Werners gata 8 S-42132 Västra Frölunda	Tel. +46 31 70968 80 Fax +46 31 70968 93 goteborg@sew.se



Sweden			
	Stockholm	SEW-EURODRIVE AB Björkholmsvägen 10 S-14146 Huddinge	Tel. +46 8 44986 80 Fax +46 8 44986 93 stockholm@sew.se
	Malmö	SEW-EURODRIVE AB Borrgatan 5 S-21124 Malmö	Tel. +46 40 68064 80 Fax +46 40 68064 93 malmo@sew.se
	Skellefteå	SEW-EURODRIVE AB Trädgårdsgatan 8 S-93131 Skellefteå	Tel. +46 910 7153 80 Fax +46 910 7153 93 skelleftea@sew.se
Switzerland			
Assembly Sales Service	Basel	Alfred Imhof A.G. Jurastrasse 10 CH-4142 Münchenstein bei Basel	Tel. +41 61 417 1717 Fax +41 61 417 1700 http://www.imhof-sew.ch info@imhof-sew.ch
Technical Offices	Rhaetian Switzerland	André Gerber Es Perreyres CH-1436 Chamblon	Tel. +41 24 445 3850 Fax +41 24 445 4887
	Bern / Solothurn	Rudolf Bühler Muntersweg 5 CH-2540 Grenchen	Tel. +41 32 652 2339 Fax +41 32 652 2331
	Central Switzerland, Aargau	Armin Pfister Stierenweid CH-4950 Huttwill, BE	Tel. +41 62 962 54 55 Fax +41 62 962 54 56
	Zürich, Ticino	Gian-Michele Muletta Fischerstrasse 61 CH-8132 Egg bei Zürich	Tel. +41 44 994 81 15 Fax +41 44 994 81 16
	Bodensee and East Switzerland	Markus Künzle Eichweg 4 CH-9403 Goldach	Tel. +41 71 845 2808 Fax +41 71 845 2809
Taiwan (R.O.C.)			
Sales	Nan Tou	Ting Shou Trading Co., Ltd. No. 55 Kung Yeh N. Road Industrial District Nan Tou 540	Tel. +886 49 255353 Fax +886 49 257878
	Taipei	Ting Shou Trading Co., Ltd. 6F-3, No. 267, Sec. 2 Tung Hwa South Road, Taipei	Tel. +886 2 27383535 Fax +886 2 27368268 Telex 27 245 sewtwn@ms63.hinet.net
Thailand			
Assembly Sales Service	Chonburi	SEW-EURODRIVE (Thailand) Ltd. 700/456, Moo.7, Donhuaroh Muang Chonburi 20000	Tel. +66 38 454281 Fax +66 38 454288 sewthailand@sew-eurodrive.com
Technical Offices	Bangkok	SEW-EURODRIVE (Thailand) Ltd. 6th floor, TPS Building 1023, Phattanakarn Road Suanluang Bangkok, 10250	Tel. +66 2 7178149 Fax +66 2 7178152 sewthailand@sew-eurodrive.com
	Hadyai	SEW-EURODRIVE (Thailand) Ltd. Hadyai Country Home Condominium 59/101 Soi.17/1 Rachas-Utid Road. Hadyai, Songkhla 90110	Tel. +66 74 359441 Fax +66 74 359442 sewthailand@sew-eurodrive.com



Thailand			
	Khonkaen	SEW-EURODRIVE (Thailand) Ltd. 4th Floor, Kaow-U-HA MOTOR Bldg, 359/2, Mitraphab Road. Muang District Khonkaen 40000	Tel. +66 43 225745 Fax +66 43 324871 sew-thailand@sew-eurodrive.com
Tunisia			
Sales	Tunis	T. M.S. Technic Marketing Service Zone Industrielle Mghira 2 Lot No. 39 2082 Fouchana	Tel. +216 79 40 88 77 Fax +216 79 40 88 66 http://www.tms.com.tn tms@tms.com.tn
Turkey			
Assembly Sales Service	Istanbul	SEW-EURODRIVE Hareket Sistemleri San. ve Tic. Ltd. Sti. Bagdat Cad. Koruma Cikmazi No. 3 TR-34846 Maltepe ISTANBUL	Tel. +90 216 4419163 / 4419164 Fax +90 216 3055867 http://www.sew-eurodrive.com.tr sew@sew-eurodrive.com.tr
Technical Offices	Adana	SEW-EURODRIVE Hareket Sistemleri San. ve Tic. Ltd. Sti. Kizilay Caddesi 8 Sokak No 6 Dađtekin Is Merkezi Kat 4 Daire 2 TR-01170 SEYHAN / ADANA	Tel. +90 322 359 94 15 Fax +90 322 359 94 16
	Ankara	SEW-EURODRIVE Hareket Sistemleri San. ve Tic. Ltd. Sti. Özcelik Is Merkezi, 14. Sok, No. 4/42 TR-06370 Ostim/Ankara	Tel. +90 312 385 33 90 Fax +90 312 385 32 58
	Bursa	SEW-EURODRIVE Hareket Sistemleri San. ve Tic. Ltd. Sti. Üçevler Mah. Bayraktepe Sok. Akay İş Merkezi Kat:3 No: 7/6 TR Nilüfer/Bursa	Tel. +90 224 443 45 60 Fax +90 224 443 45 58
	Izmir	SEW-EURODRIVE Hareket Sistemleri San. ve Tic. Ltd. Sti. 1203/11 Sok. No. 4/613 Hasan Atli Is Merkezi TR-35110 Yenisehir-Izmir	Tel. +90 232 469 62 64 Fax +90 232 433 61 05
Ukraine			
Sales Service	Dnepropetrovsk	SEW-EURODRIVE Str. Rabochaja 23-B, Office 409 49008 Dnepropetrovsk	Tel. +380 56 370 3211 Fax +380 56 372 2078 http://www.sew-eurodrive.ua sew@sew-eurodrive.ua
Sales	Kiev	SEW-EURODRIVE GmbH S. Oleynika str. 21 02068 Kiev	Tel. +380 44 503 95 77 Fax +380 44 503 95 78 kso@sew-eurodrive.ua
	Donetsk	SEW-EURODRIVE GmbH 25th anniversary of RKKA av. 1-B, of. 805 Donetsk 83000	Tel. +380 62 38 80 545 Fax +380 62 38 80 533 dso@sew-eurodrive.ua
United Arab Emirates			
Sales Service	Sharjah	Copam Middle East (FZC) Sharjah Airport International Free Zone P.O. Box 120709 Sharjah	Tel. +971 6 5578-488 Fax +971 6 5578-499 copam_me@eim.ae



Uruguay			
Sales	Montevideo	SEW-EURODRIVE Uruguay, S. A. Jose Serrato 3569 Esquina Corumbe CP 12000 Montevideo	Tel. +598 2 21181-89 Fax +598 2 21181-89 sewuy@sew-eurodrive.com.uy
USA			
Production Assembly Sales Service Corporate Offices	Southeast Region	SEW-EURODRIVE INC. 1295 Old Spartanburg Highway P.O. Box 518 Lyman, S.C. 29365	Tel. +1 864 439-7537 Fax Sales +1 864 439-7830 Fax Manufacturing +1 864 439-9948 Fax Assembly +1 864 439-0566 Fax Confidential/HR +1 864 949-5557 http://www.seweurodrive.com cslyman@seweurodrive.com
Assembly Sales Service	Northeast Region	SEW-EURODRIVE INC. Pureland Ind. Complex 2107 High Hill Road, P.O. Box 481 Bridgeport, New Jersey 08014	Tel. +1 856 467-2277 Fax +1 856 845-3179 csbridgeport@seweurodrive.com
	Midwest Region	SEW-EURODRIVE INC. 2001 West Main Street Troy, Ohio 45373	Tel. +1 937 335-0036 Fax +1 937 332-0038 cstroy@seweurodrive.com
	Southwest Region	SEW-EURODRIVE INC. 3950 Platinum Way Dallas, Texas 75237	Tel. +1 214 330-4824 Fax +1 214 330-4724 csdallas@seweurodrive.com
	Western Region	SEW-EURODRIVE INC. 30599 San Antonio St. Hayward, CA 94544	Tel. +1 510 487-3560 Fax +1 510 487-6433 cshayward@seweurodrive.com
Additional addresses for service in the USA provided on request!			
Venezuela			
Assembly Sales Service	Valencia	SEW-EURODRIVE Venezuela S.A. Av. Norte Sur No. 3, Galpon 84-319 Zona Industrial Municipal Norte Valencia, Estado Carabobo	Tel. +58 241 832-9804 Fax +58 241 838-6275 http://www.sew-eurodrive.com.ve ventas@sew-eurodrive.com.ve sewfinanzas@cantv.net
Vietnam			
Sales	Ho Chi Minh City	Nam Trung Co., Ltd 91 - 93 Tran Minh Quyen Street, District 10, HCMC	Tel. +84 8 8301026 Fax +84 8 8392223 namtrungco@hcm.vnn.vn



Index

A

Absolute encoder card type DEH21B/DIP11B	82
Additional functions	22
Application modules	26
Application variant	22
Approvals	21

B

Block circuit diagram for MOVIDRIVE®	18
Brake module BST	127
Braking resistors	
Assignment to AC 230 V units	144
Assignment to AC 400/500 V units	141
BW... / BW...-T / BW...-P	139
Flat-type	139
Parallel connection	140
UL and cUL approval	140
Wire and grid resistors	139
BST	127

C

Cable sets for DC link connection	163
Cable sets for the DC link connection, MDR60A regenerative power supply units	78
CANopen DFC11B	108
CE-marking	37
Characteristics of IPOSplus®	67
CM brakemotor cable	165
CM motor cable	164
CMP brakemotor cable for BP brake	166
CMP brakemotor cable for BY brake	167
CMP/CMD motor cable	166
Communication	20
Communication options	7
Connector adapter	85
Encoder adapter X14 DAE14B	86
Control functions	19
Control modes, general description	15
Control options	9
Controller DHE/DHF/DHR21	121

Controller DHE/DHF/DHR41B	121
Controller DH.21B/41B	
Freely programmable controller (MOVI-PLC®)	121
C-Tick approval	37
cUL approval	
Braking resistors	140

D

DAE14B, encoder adapter X14	86
DAE15B	85
DAT11B	85
DBG60B	69
DBG60B keypad option	69
DBM60B	71
DBM60B/DKG60B housing	71
DCS21B	116
DCS31B	116
DEH11B	79
DEH11B Hiperface® encoder card	79
DEH21B	82
DER11B	80
Description, general	11
DEU21B	81
DeviceNet DFD11B	107
DFC11B	108
DFD11B	107
DFE24B	106
DFE32B	102
DFE33B	104
DFI11B	100
DFI21B	101
DFP21B	99
DFS11B	110
DFS12B	112
DFS21B	113
DFS22B	115
DHE/DHF/DHR21	121
DHE/DHF/DHR41B	121
DHP11B	119



Dimension drawings	
Braking resistors BW... / BW...-T / BW...-P	146
BW003-420-T braking resistor	147
BW1.4-170 braking resistor	147, 148
DBG60B	70
DBM60B/DKG60B	71
DKB11A heat sink	149
HF...-403 output filter	162
HF...-503 output filter	161
MDR60A regenerative power supply units	76
ND line choke	151
NF line filter	154
NF600-503 line filter	155
Output chokes HD001-HD003	156
Output chokes HD004	157
Output chokes HD0045	158
Size 0M	56, 58
Size 0S	55, 57
Size 1	59
Size 2S	60, 61
Size 3	62
Size 4	63
Size 5	64
Size 6	65
Size 7	66
USB11A	93
UWS11A	89
UWS21B	91
DIO11B	97
DIP11B	82
DKB11A	149
DKB11A heat sink for braking resistors in flatpack design	149
DKG60B	71
DLA11B	134
DLA11B connection kit	134
DLB11B	130
DLB11B touch guard option	130
DLB21B	131
DLB21B touch guard option	131
DLH11B	133
DLH11B wall bracket	133
DLK11B	135
DLK11B air duct	135
DLS11B	132
DLS11B mounting base	132
DLZ11B	136
DLZ11B DC link coupling	136
DLZ12B	137
DLZ14B	138
DMP11B	129
DMP11B mounting panel	129
DRS11B	109
DRS11B synchronous operation card	109
DWE11B/12B	87
DWI11A	95
E	
Electronic cam	22
Encoder adapter X15, DAE15B	85
Encoder cable	
For distance encoders	182
For DR motors	169
For DT/DV/CMP, CM motors	176
Encoder cables	
For resolver	187
Encoder options	7
Encoder supply (5 V) DWI11A	95
Engineering software	35
EtherCAT DFE24B	106
EtherNet/IP DFE33B	104
Expansion of the system	21
F	
Fieldbus interface	
PROFIBUS DFP21B	99
Fieldbus interfaces	
CANopen DFC11B	108
DeviceNet DFD11B	107
DFI21B INTERBUS optical fiber	101
DFS21B PROFINET IO with PROFI-safe	113
DFS22B PROFINET IO with PROFI-safe	115
EtherCAT DFE24B	106
EtherNet/IP DFE33B	104
INTERBUS DFI11B	100
PROFIBUS DP-V1 with PROFI-safe DFS11B	110
PROFIBUS DP-V1 with PROFI-safe DFS12B	112
PROFINET IO RT DFE32B	102
Fieldbus options	8
Freely programmable controller (MOVI-PLC®)	121
G	
Grid resistors	139
H	
HTL -> TTL	87



I	
Input/output card DIO11B	97
INTERBUS DFI11B	100
INTERBUS optical fiber DFI21B	101
Interface adapter	
DWE11B/12B	87
USB11A	93
UWS11A	89
UWS21B	91
Internal synchronous operation	24
IPOS ^{plus} ® characteristics	67
IPOS ^{plus} ®, general description	15, 67
L	
Line chokes ND	150
Line filter NF...-	152
Long-term storage	38
M	
Meaning of the symbols	168
Modular structure	13
Motor selection	190
Asynchronous AC motors	190
Asynchronous servomotors	206
Recommendations for motor selection	190
Synchronous servomotors (SERVO)	272
Motor selection for asynchronous AC motors (VFC)	
Dynamic applications	192
Speed/torque characteristic curve	191
Voltage/frequency characteristic curve	190
Motor selection for asynchronous servomotors (CFC)	
CFC operation with speed control	207, 208
Magnetizing current	206
Motor characteristics	206
Motor cooling	207
Notes for DRL motors	209
Mounting panel DMP11B	129
MOVIDRIVE® product family	11
MOVILINK®, general description	15
MOVI-PLC® basic DHP11B.. controller	119
MOVISAFE® DCS21B/31B safety	
module option	116
MOVITOOLS® Motion Studio	35
Multi-encoder card type DEU21B	81
O	
Online help	36
Operation	20
Option	
CANopen DFC11B fieldbus interface	108
DBG60B keypad	69
DBM60B/DKG60B housing	71
DEH11B Hiperface® encoder card	79
DEH21B/DIP11B absolute	
encoder card option	82
DER11B resolver card	80
DEU21B multi-encoder card	81
DeviceNet DFD11B fieldbus interface	107
DFE32B PROFINET IO RT	
fieldbus interface	102
DFE33B EtherNet/IP fieldbus interface	104
DFI21B INTERBUS optical fiber	
fieldbus interface	101
DFP21B PROFIBUS fieldbus interface	99
DFS11B PROFIBUS DP-V1 with	
PROFIsafe fieldbus interface option	110
DFS12B PROFIBUS DP-V1 with	
PROFIsafe fieldbus interface option	112
DFS21B fieldbus interface	
PROFINET IO with PROFIsafe	113
DFS22B fieldbus interface	
PROFINET IO with PROFIsafe	115



DHE/DHF/DHR21 controller	121
DHE/DHF/DHR41B controller	121
DIO11B input/output card	97
DKB11A heat sink for braking resistors	149
DLA11B connection kit.....	134
DLB11B touch guard.....	130
DLB21B touch guard option.....	131
DLH11B wall bracket	133
DLK11B air duct.....	135
DLS11B mounting base	132
DLZ11B DC link coupling.....	136
DRS11B synchronous operation card.....	109
DWE11B/12B interface adapter.....	87
Encoder supply (5 V) DWI11A	95
Fieldbus interface EtherCAT DFE24B	106
HD... output choke	156
INTERBUS DFI11B fieldbus interface	100
MOVI-PLC® basic DHP11B.. controller	119
MOVISAFE® DCS21B/31B safety module.....	116
ND.. line chokes.....	150
NF...line filter.....	152
OST11B	120
Output filter HF.....	159
Safety-related brake module BST.....	127
USB11A interface adapter	93
UWS11A interface adapter	89
UWS21B interface adapter	91
2Q DLZ12B DC link adapter	137
4Q DLZ14B DC link adapter	138
Option card slots	13
OST11B	120
Output choke HD...	156
Output filter HF.....	159
Overview of options	
Communication	7
Control	9
Encoder.....	7
Fieldbus	8
Safety.....	10
Overview of the MOVIDRIVE® units	16
P	
Parallel connection	
Braking resistors	140
Power components	6
Prefabricated cables	163
CM brakemotor cable	165
CM motor cable	164
CMP brakemotor cable for BP brake	166
CMP brakemotor cable for BY brake	167
CMP/CMD motor cable.....	166
Encoder cable for DT/DV/CMP, CM motors	176
Encoder cables for distance encoders.....	182
Encoder cables for DR motors.....	169
Encoder cables for resolvers	187
Meaning of the symbols.....	168
Overview.....	117, 163
PROFIBUS DFP21B.....	99
PROFIBUS DP-V1 with PROFIsafe DFS11B	110
PROFIBUS DP-V1 with PROFIsafe DFS12B	112
PROFINET IO RT DFE32B	102
PROFINET IO with PROFIsafe DFS21B	113
PROFINET IO with PROFIsafe DFS22B	115
PTC resistor BW090-P52B	139
R	
Regenerative power supply, MDR60A	
Cable sets for the DC link connection.....	78
Description.....	72
General technical data.....	73
UL approval	72
Resolver card type DER11B.....	80
S	
Safety options	10
Safety-oriented brake module BST.....	127
Setpoint technology	20
Standards	21
Storage temperature.....	38
System bus (SBus).....	15
System expansion	21
System overview.....	6



T

Technical data

BW...-T / BW...-P braking resistors	145
Electronics data – basic units	53
General information	38
MDR60A regenerative power supply unit	73, 74
Size 0 (AC 400/500 V units).....	40
Size 1 (AC 230 V units).....	49
Size 1 (AC 400/500 V units).....	42
Size 2 (AC 230 V units).....	50
Size 2 (AC 400/500 V units).....	43
Size 2S (AC 400/500 V units)	43
Size 3 (AC 230 V units).....	51
Size 3 (AC 400/500 V units).....	44
Size 4 (AC 230 V units).....	52
Size 4 (AC 400/500 V units).....	45
Size 5 (AC 400/500 V units).....	46
Size 6 (AC 400/500 V units).....	47
Size 7 (AC 400/500 V units).....	48
Technical support.....	36
Terminal adapter DAT11B	85

Touch guard BS.....	148
---------------------	-----

U

UL approval	37
Braking resistors	140
MDR60A regenerative power supply	72
Unit concept.....	13
Unit features	19
Unit functions	19
Unit properties	19
USB11A	93
UWS11A	89
UWS21B	91

W

Wire resistors.....	139
---------------------	-----

0 ... 9

2Q DLZ12B DC link adapter	137
4Q DLZ14B DC link adapter	138

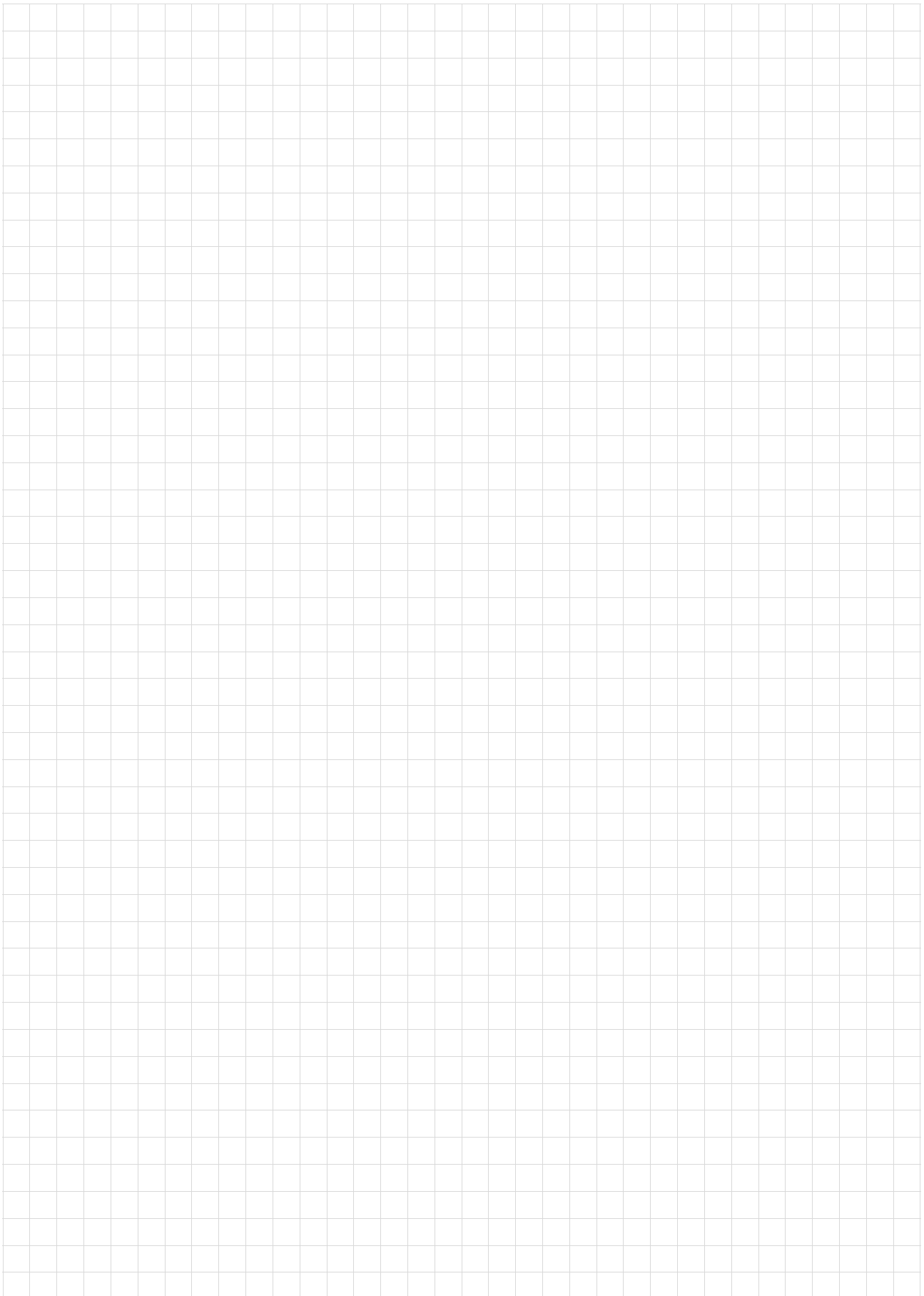

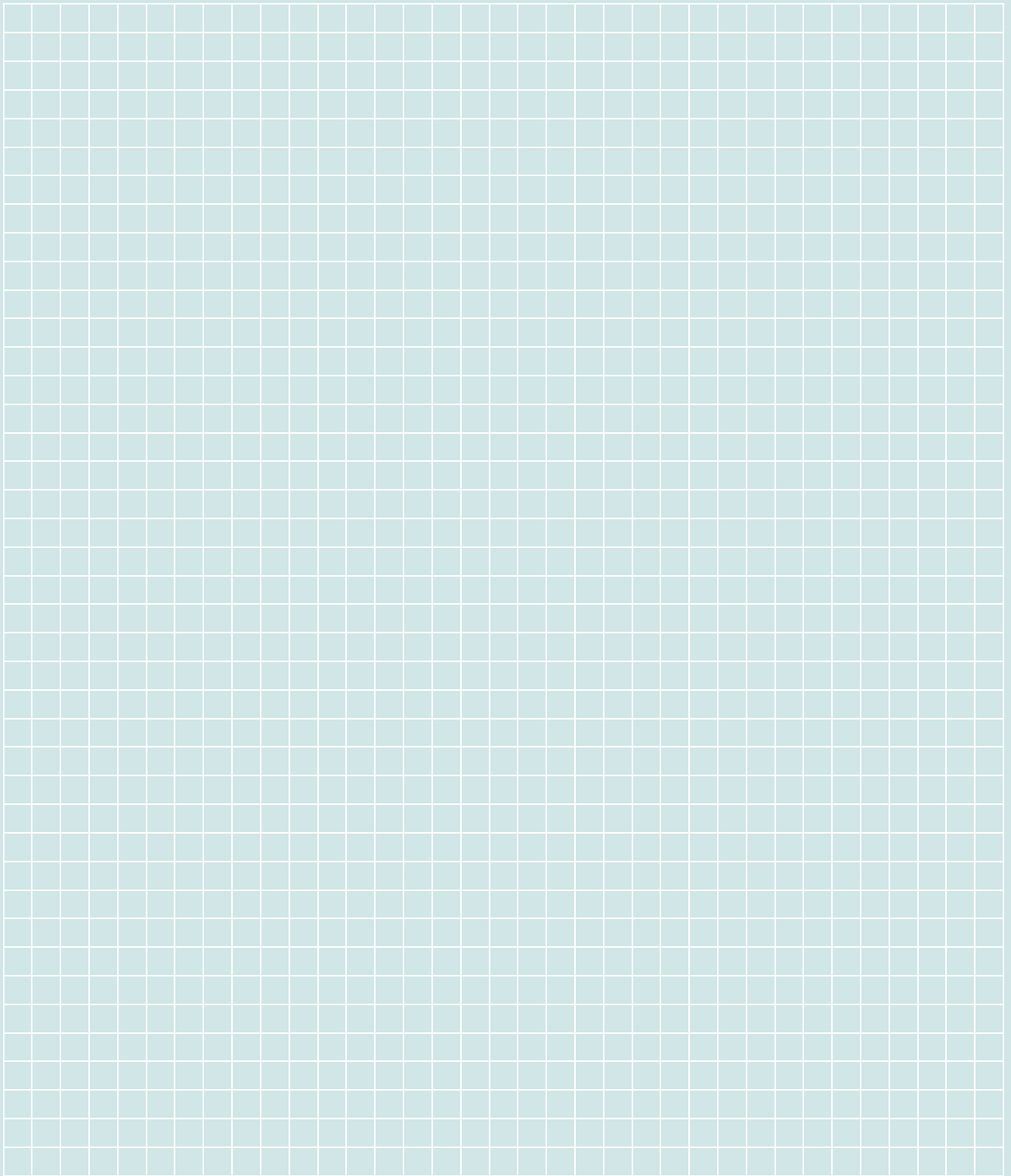



SEW-EURODRIVE
Driving the world

SEW
EURODRIVE

SEW-EURODRIVE GmbH & Co KG
P.O. Box 3023
D-76642 Bruchsal/Germany
Phone +49 7251 75-0
Fax +49 7251 75-1970
sew@sew-eurodrive.com

→ www.sew-eurodrive.com